



WEAVER CONSTRUCTION MANAGEMENT, INC.
 3679 S. Huron St., Suite 404
 Englewood, CO 80110
 Phone: (303) 789-4111 FAX: (303) 789-4310

SUBMITTAL TRANSMITTAL

September 13, 2011

WCM Submittal No: 11314-001.A

PROJECT: Harold Thompson Regional WRF
 Birdsall Rd.
 Fountain, CO 80817
 Job No. 2908

ENGINEER: **GMS, Inc.**
 611 No. Weber St., #300
 Colorado Springs, CO 80903
 719-475-2935 Roger Sams

OWNER: **Lower Fountain Metropolitan
 Sewage Disposal District**
 901 S. Santa Fe Ave.
 Fountain, CO 80817
 719-382-5303 James Heckman

CONTRACTOR: **Schloss Engineered Equipment, Inc.**
 10555 E. Dartmouth Ave., Suite 230
 Aurora, CO 80014
 303-695-4500 Linda Wood

SUBJECT: Resubmittal – revised configuration for the grit pumps per GMS comments dated September 7, 2011 requiring a common base for the pump and top-mounted motor.

SPEC SECTION: 11314 - Recessed Impeller Pumps

PREVIOUS SUBMISSION DATES: 8/8/11

DEVIATIONS FROM SPEC: ___ YES X NO

CONTRACTOR'S STAMP: This submittal has been reviewed by Weaver General Construction and approved with respect to the means, methods, techniques, & safety precautions & programs incidental thereto. Weaver General Construction also warrants that this submittal complies with contracted documents and comprises on deviations thereto:

Contractor's Stamp:

Date: 9/13/11
 Reviewed by: H.C. Myers
 (X) Reviewed Without Comments
 () Reviewed With Comments

Engineer's Stamp:

**ENGINEER'S
 COMMENTS:**

JOB #: _____

SUCTION AND DISCHARGE MATCH 150#
CLASS CAST IRON 4 INCH FLANGE

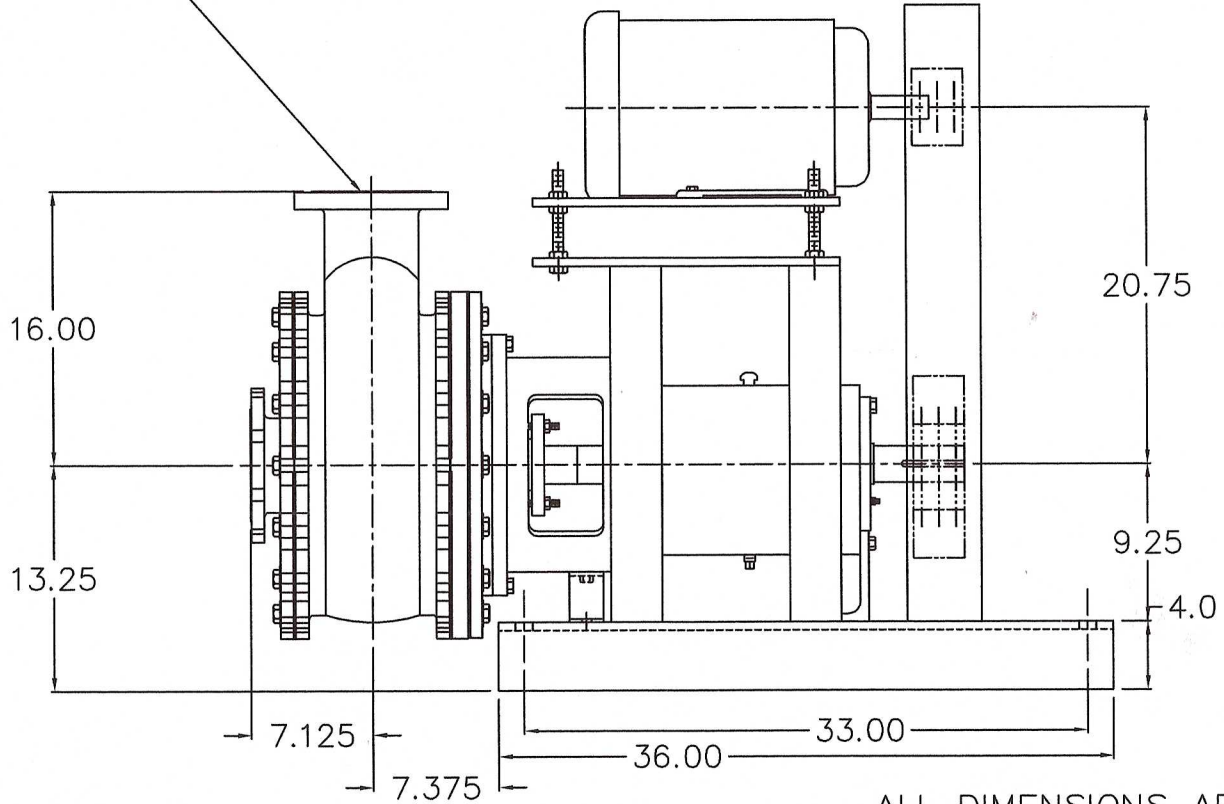
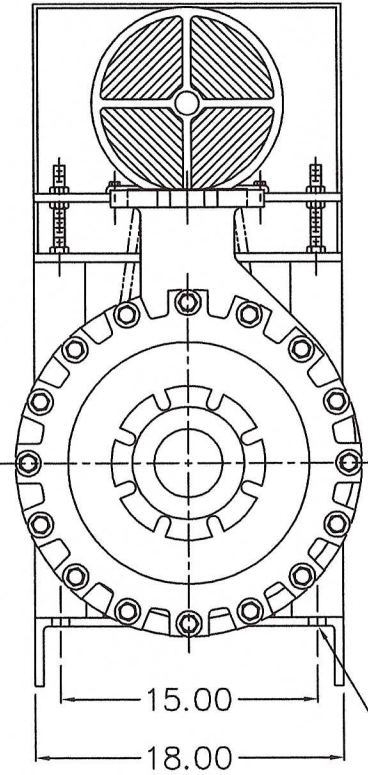

4-.75" HOLES ON CENTERS SHOWN

ALL DIMENSIONS ARE IN INCHES

DATE:
4/23/90
FILE NAME:
HDPLP416
DRAWN BY:
BRAD J. MANN
CHECKED BY:
J.I.
REVISED BY:
K PADGETT
REV. DATE:
3/31/94

ESSCO PUMPS

4X16 HDPL 100%
RECESSED IMPELLER PUMP
"C" FLOW CONFIGURATION