



Weaver

CONSTRUCTION MANAGEMENT

3679 S Huron Street, Suite 404 Englewood, Colorado 80110

Phone: (303) 789-4111 FAX: (303) 789-4310

SUBMITTAL TRANSMITTAL

June 26, 2012

Submittal No: 11315-001

PROJECT: **Harold Thompson Regional WRF**
Birdsall Rd.
Fountain, CO 80817
Job No. 2908

ENGINEER: **GMS, Inc.**
611 No. Weber St., #300
Colorado Springs, CO 80903
719-475-2935 Roger Sams

OWNER: **Lower Fountain Metropolitan
Sewage Disposal District**
901 S. Santa Fe Ave.
Fountain, CO 80817
719-382-5303 James Heckman

CONTRACTOR: **Seepex, Inc.**
511 Speedway Drive
Enon, OH 45323
937-864-7150 Hector Santiago

SUBJECT: Progressive Cavity Pumps SCP-1 and SCP-2, and DSP-1 and DSP-2

SPEC SECTION: 11315: Progressive Cavity Pumps

PREVIOUS SUBMISSION DATES:

DEVIATIONS FROM SPEC: ___ YES X NO

CONTRACTOR'S STAMP: This submittal has been reviewed by Weaver Construction Management and, unless indicated otherwise, has been found to be in conformance with the intent of the contract documents.

Contractor's Stamp:

Engineer's Stamp:

Date: 6/26/12

Reviewed by: John Jacob

() Reviewed Without Comments

(X) Reviewed With Comments

ENGINEER'S
COMMENTS:



Project: HDTWRF Project

Location: Fountain, CO

Supplier: Seepex, Inc

Date: 6/26/12

Submittal 11315-01 Progressive Cavity Pumps SCP-1 and 2; DSP-1 and 2.

Additional Submittal Review Comments:

1. Submittal contains terms & conditions which are not applicable to this submittal. T&Cs have been agreed to in the Purchase Agreement between WCM and Seepex.
2. Pages 4 to 6 provide information on long term preservation information. This information shall be incorporated into the O&M manual.
3. Submittal contains a warranty card. Warranty information shall be completed and provided in a separate O&M submittal.
4. Cartex Single cartridge seals product is provided, but the specific model and materials of construction are not provided. Specify specific product.
5. DSP - Confirm that the pump and motor are designed for an altitude of 5390 feet above sea level.
6. DSP - The maximum motor operating speed (nominal) is stated as 1765 rpm while section in the submittal however 2.1.C.5 states 900 rpm.
7. DSP – need to confirm BHP.
8. DSP – confirm that a SS trough beneath pump gland is being provided per section 2.3.C.3.
9. DSP – page 27 and 28. it appears that the discharge is 5” with a 5” x 6” expansion joint. The discharge process pipe noted on Sheet PD-14 is 4”. Please provide a 5” x 4” expansion joint instead of 5 x 6.
10. DSP – page 31. It appears that the NPSH is 13.5 feet while Section 2.1.C.9. indicates NPSH is 12.0.
11. SCP - Confirm that the pump and motor are designed for an altitude of 5390 feet above sea level.
12. SCP - The maximum motor operating speed (nominal) is stated as 1755 rpm while section in the submittal however 2.1.B.5 states 900 rpm.
13. SCP - need to confirm BHP.
14. SCP - confirm that a SS trough beneath pump gland is being provided per section 2.3.B.3.

15. SCP - page 55 and 56. it appears that the discharge is 4" with a 4" x 6" expansion joint. The discharge process pipe noted on Sheet PD-14 is 4". Please provide a 4" x 4" expansion joint instead of 4 x 6.
16. SCP - page 59. It appears that the NPSH is 8.5 feet while Section 2.1.B.9. indicates NPSH is 12.0.

End of Review by WCM.

Progressive Cavity Pump Submittal

Supply of **seepex, Inc.** pumps & accessories: consisting of engineering drawings, descriptive literature, operating data and related information.

To:

Weaver Construction Management, Inc.
3679 S. Huron St.
Suite 404
Englewood, CO 80110-3498
Phone#: 303-789-4111, Fax#: 303-789-4310
Attn: Wesley Weaver, President

c/o:

Harold D. Thompson Water Reclamation Facility
Fountain, CO 80817

PO#: 9103

seepex Job#: 2113909

Specifications Section: PROGRESSING CAVITY PUMP

Equipment No:

<u>Denomination:</u>	<u>Pump Type:</u>	<u>Commission#’s:</u>	<u>Tag#’s:</u>
Digested Sludge	BN 52-6L	832027-028	DSP-1 & 2
Scum	BN 35-6L	832029-032	SCP-1 & 2

Represented Locally By:

Ambiente H2O Inc.
Wastewater & Water Treatment Specialists
1500 W. Hampden Ave.,
Suite 5D
Sheridan, CO 80110
Phone #: 303-433-0364, Fax #: 303-380-0664
Attn: Brian Johnson, bjohnson@ambienteh2o.com

By:

seepex, Inc.
511 Speedway Dr.
Enon, OH 45323
Phone#: 937-864-7150, Fax#: 937-864-7157

June 2012

seepex.com		
Weaver Constr-Englewood, CO-Ambiente H2O-Harold D Thompson Water Reclam Facility		PO#: 9103
Table of Contents-Submittal		seepex Job#: 2113909
Tabs	Sections	Page #'s
1	<u>General Data</u>	
	Long Term Preservation Guidelines	4-6
	Terms and Conditions	7
	Warranty Card	8
	Paint Specifications TNEMEC	9-12
	Nameplate	13
	Duktil Coating	14
	TSE-Dry Running Protection Device	15-18
	Sectional Drawing	19
	Parts Listing	20-21
	Mechanical Seal Arrangement	22
	Mechanical Seal Drawing	23
2	<u>Pump Technical Data:</u>	
	BN 52-6L Data Sheet CN#: 832027-028	25-27
	Dimensional Drawing	28
	Characteristic Curve	29
	NPSH Curve	30-31
	Performance Data	32
	Nord Gear Reducer	33-42
	WEG Motor	43-51
3	<u>Pump Technical Data:</u>	
	BN 35-6L Data Sheet CN#: 832029-030	53-55
	Dimensional Drawing	56
	Characteristic Curve	57
	NPSH Curve	58-59
	Performance Data	60
	Nord Gear Reducer	61-70
	WEG Motor	71-79
4	<u>Pump Accessories</u>	
	Anchor Bolts	81-82
	Over Pressure Protection	83-95
	Proco Flex Joint	96-105
5	<u>General Brochures</u>	
	Product group N	107-112

Tab 1

General Data

1 Scope

Size	Period of Storing	Preservation acc. to.
025-12 ... 130-6L	> 3 months ≤ 9 months	Measures for preservation 1
	> 9 months	Measures for preservation 2
130-12 ... 500-6L	> 3 months ≤ 9 months	Measures for preservation 1
	> 9 months	Measures for preservation 2

2 Description

2.1 Measures for preservation 1

2.1.1 Storing of the pump

- in dry and closed rooms
- free from vibration

Particular adjacent influences have to be advised by the customer and have to be checked and released by seepex before storage.

2.1.2 Protection of the drive shaft (only for ranges N, NS)

Moisten exposed surfaces of the drive shaft with corrosion inhibitor/spray wax.

2.1.3 Protection of the stator

change the position of the once per month:

- Remove fan cover on the electric motor.
- Rotate the fan shaft 1/4 turn.

Fan shaft and fan must not be damaged! If necessary remove the fan and protect the shaft against damage during this procedure.

2.1.4 Gear

Note instruction of the manufacturer.

- Follow advice on the gear.

- | |
|---|
| <ul style="list-style-type: none"> • Reduce quantity of lubricant to the quantity stipulated for the operation before commissioning! • Reinstall vent screw during commissioning. |
|---|

Belt Variable Speed Drive:

Store the belt separate (relevant standard ISO 2230):

- dry
- constant tempered at 10-15°C (max. 25°C)
- protected against light / stored in darkness (e.g. in a closed case or packed accordingly)

2.1.5 Motor

By the turn of the fan shaft (see point 2.1.2) a protection of the bearing in the motor is obtained at the same time.

2.1.6 Recommissioning

	NOTICE
	<p>Before starting work read the operating instruction.</p> <ul style="list-style-type: none">• Pay attention to a correct re-assembly of parts dismantled before.

2.2 Measures for preservation 2

In case of the correct storage and under consideration of the preservation measures, a storage of the pump is possible for max. 2 years.

NOTICE
<p>In case of a longer storage period, the dimensions and shore hardness can change. The function of the pump can be impaired.</p> <ul style="list-style-type: none">➤ Bevor recommissioning Elastomere parts (stator, joint seal, gaskets, ...) have to be checked for crack formation and change of the surface.

2.2.1 Storing of the pump/pump parts

- in dry and closed rooms
- free from vibration

Particular adjacent influences have to be advised by the customer and have to be checked and released by seepex before storage.

2.2.2 Protection of the drive shaft (only for ranges N, NS)

Moisten exposed surfaces of the drive shaft with corrosion inhibitor/spray wax.

2.2.3 Storing of the stator

Store the stator separate (relevant standard ISO 2230):

- dry
- constant tempered at 10-15°C (max. 25°C)
- protected against light / stored in darkness (e.g. in a closed case or packed accordingly)

2.2.4 Gear

Note instruction of the manufacturer.

- Follow advice on the gear.

- Reduce quantity of lubricant to the quantity stipulated for the operation before commissioning!
- Reinstall vent screw during commissioning.

Belt Variable Speed Drive:

Store the belt separate (relevant standard ISO 2230):

- dry
- constant tempered at 10-15°C (max. 25°C)
- protected against light / stored in darkness (e.g. in a closed case or packed accordingly)

2.2.5 Motor

Turn the fan shaft once a month to protect the bearing:

- Remove fan cover on the electric motor.
- Rotate the fan shaft 1/4 turn.

Fan shaft and fan must not be damaged! If necessary remove the fan and protect the shaft against damage during this procedure.

2.2.6 Recommissioning

	NOTICE
	<p>Before starting work read the operating instruction.</p> <ul style="list-style-type: none">• Pay attention to a correct re-assembly of parts dismantled before.

3 Advices and annotations

Guarantee-/Warranty claims cannot be derived from this document.

4 Alteration service

This document is subject to the alteration service of the engineering department (TE) and ist relevant valid issue is released by the quality assurance (QA). All alteration requests are handled and checked by engineering.

TERMS & CONDITIONS OF SALES AND/OR REPAIR

The following terms and conditions shall apply to an order for all or any part the articles covered by this quotation unless specifically excepted therein:

Prices

Any prices quoted shall only be valid for orders placed within 30 days from the date of issue of the quotation. Prices are F.O.B. our plant in U.S. or Canadian dollars. We reserve the right to correct typographical or clerical errors.

Terms

All orders are subject to approval by our Credit Department. Unless otherwise stated, if payment for the invoice due is not made within thirty (30) days after shipment, administration fees of eighteen percent (18%) per year (equivalent to a nominal monthly interest rate of 1½%) will be applied on overdue accounts. The terms and conditions herein set forth are based upon tariffs, taxes, foreign exchange rates, delivery, and other conditions in effect on the date of this contract. In the event changed conditions, legislations, regulations, or other matters shall become applicable to any quotation, contract, or delivery hereunder, any increased exchange, duties, taxes, ocean freight, or other charges resulting from such action shall be for the customer's account and seepex, Inc. may charge such increased duties, taxes, or charges to the customer.

Unless the order includes the appropriate exemption certificates and/or licenses, duties, and taxes levied by Federal, State, or other governments are required to be charged automatically at the rate imposed at time of importation/shipment. Any change in law, regulations, or Government Department practice which causes a variation of any kind in the applicable charges from the amounts allowed for the quotation, shall result in an equivalent change in the price quoted.

Until payment is made in full, seepex, Inc. shall retain the right, without notice, to repossess and/or retain the items, and/or dispose of them, for its benefit and hold the customer responsible for any loss. Customer agrees to enter into any agreements, contracts, or notices required to confirm such rights.

Security

In order to secure any obligations due to seepex, Inc. from the customer (whether or not under this contract) the customer grants and confirms in seepex, Inc. a security interest in:

- a) the merchandise covered by this contract, and
- b) in all property and funds of the customer now or hereafter in seepex, Inc. possession, whether or not arising out of this contract, and in all additions, accessions, and proceeds of such merchandise and/or property. The customer hereby authorizes seepex, Inc. to sign alone any financing statement or statements and to do all and any other things which may be necessary to perfect such security interest.

Cancellation

After acceptance, orders may be canceled only with our approval and payment in accordance with contract by the customer for work performed and/or material expenses incurred by us to date of cancellation. We reserve the right to cancel the order if the customer's financial condition, in our sole judgment, places the payment in jeopardy.

Return

No credit will be allowed for returns unless our authorization in writing for such returns has been obtained beforehand. A copy of this authorization is to be returned with the item as the packing slip.

Shipment

- a) Handling Charge: Customer shall be responsible for making all arrangements for shipment of the order with a suitable carrier. In the event that customer requests that seepex make arrangements for shipment, then customer agrees to pay to seepex, in addition to the applicable shipping charges, a handling charge in the amount of 10% of the shipping charges with a minimum \$5.00 to a maximum charge of \$150.00, with special services requiring additional charges.
- b) New Articles: Where shipping instructions indicate no exact routing, our best judgement will be used in determining routing but we shall not be liable for any charges beyond F.O.B. point. If changes are made at customer's request in a) F.O.B. point, b) in our normal routing from either the manufacturers' or our own plants and in these changes involve extra costs, such costs shall be for the customer's account, unless otherwise noted on the seepex price quotation.
- c) Repair Work: Defined as work and services performed by seepex, Inc. All orders shall be delivered to and picked up from our plant unless otherwise specified. All costs of delivery shall be for the customer's account unless otherwise agreed to in writing prior to shipment.
- d) All Orders: On collect freight shipments, cartage charges from plant to carrier are for customer's account. Title to articles passes to customer upon delivery to carrier acting as customer's agent subject to any right of retention by us. All claims for shortage in, and damages in, shipment or otherwise must be reported to carrier immediately upon receipt with copy or report to ourselves within five (5) days.

Guarantee

- a) New Articles: We guarantee articles of our manufacture against defects in material and/or workmanship for a period of three (3) years from date of acceptance, providing that the articles have been installed, maintained, and operated in accordance with our recommendations and instructions.
- b) Repair Work: Defined herein as work and services performed by seepex, Inc. We

guarantee all work and services performed by us against defect arising from workmanship and/or materials provided by us for a period of ninety (90) calendar days from the date of shipment to customer.

- c) All Orders: Claims shall be submitted promptly in writing to seepex, Inc. Replacement and/or repair under guarantee shall be made F.O.B. our plant. Our liability under these guarantees is limited to the replacement and/or repair only of defective material or workmanship and in no event shall seepex, Inc. be liable for any loss or damage of whatever kind of nature out of defects in material and/or workmanship, or resulting from delay, or loss of use of articles, or any installation into which the article may be installed, or arising out, of the contract of the work or service or from negligence.

seepex, Inc. shall not be liable for any loss or damage resulting from delay and/or late delivery due to causes beyond our reasonable control. In no event shall seepex, Inc. be liable for any claim exceeding the amount of this order. Our guarantee on products of other than our own manufacture is limited to the guarantee extended to us by the original manufacturer. On any claims for repairs and/or replacement under such guarantee, all costs incurred by us which are not underwritten by the original manufacturers shall be for the claimant's account. Except as stated above no representations, conditions, or warranties are made with respect to products, work, or services, express or implied verbal or otherwise, including warranties of merchantability and fitness. Our guarantee and warranty shall not apply to materials or workmanship which have been subject to misuse, neglect, or accident. seepex, Inc. shall be held free and harmless from any dispute or claim anywhere arising relating to infringement of patent, design, trademark, or copyright of items, sold or repaired under this contract.

Property rights and risks

The customer's property at all times shall remain at the risk of the customer while being worked on by our personnel or on our premises and shall not be responsible for any loss or damage to the customer's property resulting from any cause whatsoever.

Title to and rights in relation to item sold under this contract/quotations shall remain with seepex, Inc. until such items are paid for, subject to risk on products sold passing to the customer upon acceptance by a carrier or other, which shall constitute good delivery.

Warranty Card

Complete and return to validate warranty

Please complete this card and return it to **seepex** Inc. By using this card, the valid warranty period will commence at the pump "start-up" date. If this card is not completed the warranty coverage period will commence on the date the pump is shipped from the **seepex** factory. This card must be completed and mailed no later than one year from the date of shipment.

User Entity: _____
Mailing Address: _____

Contact Person: _____
Phone Number: _____
Fax Number: _____

Pump Model # _____
Pump Commission #: _____
Pumped Product: _____
Diff. Pressure: _____ Flow Rate: _____
Temperature: _____ Viscosity: _____
Solids Size: _____ Solids %: _____

Was the pump delivered as scheduled? Yes No
Was the appearance of the pump acceptable? Yes No
Did the pump suffer any freight damage? Yes No

Did the pump perform as expected? Yes No
Did you receive: - Data Sheets? Yes No
-O&M Manuals? Yes No
Did you local seepex distributor contact you to arrange a start-up? Yes No

Other Comments: _____

Name of person completing card (please print): _____
Date: _____ Signature: _____

PRODUCT PROFILE

GENERIC DESCRIPTION	Phenolic Alkyd
COMMON USAGE	Lead- and chromate-free, fast-drying, corrosion-resistant primer that accepts a variety of high-performance topcoats. Ideally suited for steel fabricators, OEM's and field applications where "dry-fall" characteristics are desired. Note: Not recommended for immersion.
COLORS	77 Red, 77W White, 78 Gray
PERFORMANCE CRITERIA	Extensive test data available. Contact your Tnemec representative for specific test results.

COATING SYSTEM

TOPCOATS	Series 2H, 6, 23, 27, 28, 29, 30, 66, N69, 73, 113, 114, 161, 175, 180, 181, 1074, 1075. Note: Some systems are not recommended for frequently sweating or continually wet conditions. Reference the applicable topcoat data sheet for additional information. Also, an additional coat of 37H is suggested before applying Series 6, 180 or 181. Contact Tnemec Technical Services for details.
----------	--

SURFACE PREPARATION

STEEL	Enclosed or Protected: SSPC-SP3 Power Tool Cleaning Weather-Exposed: SSPC-SP6/NACE 3 Commercial Blast Cleaning
CAST/DUCTILE IRON	Contact your Tnemec representative or Tnemec Technical Services.
ALL SURFACES	Must be clean, dry and free of oil, grease and other contaminants.

TECHNICAL DATA

VOLUME SOLIDS*	58.0 ± 2.0%
RECOMMENDED DFT	2.0 to 3.5 mils (50 to 90 microns) per coat.
CURING TIME	Temperature To Handle To Recoat With Series:

75°F (24°C)	2 hours	2H, 23, 180, 181	27•, 66•, 161•	28, 29, 30	N69, 73, 113, 114, 175, 1074, 1075
		12 hours	48 hours	7 days	30 days

Curing time varies with surface temperature, air movement, humidity and film thickness.

Note: Allow 37H to cure 14 days if 27, 66 or 161 is to be used as an intermediate coat and topcoated with 73, 175, 1074 or 1075. Then allow 27, 66 or 161 to cure an additional 24 hours before topcoating.

Water Tank Exteriors: Five days or more curing required before filling.

VOLATILE ORGANIC COMPOUNDS*	Unthinned	Thinned 4%	Thinned 9%
	2.91 lbs/gallon (348 grams/litre)	3.07 lbs/gallon (368 grams/litre)	3.27 lbs/gallon (391 grams/litre)
HAPS	1.37 lbs/gal solids	1.89 lbs/gal solids	2.51 lbs/gal solids
THEORETICAL COVERAGE*	930 mil sq ft/gal (22.8 m ² /L at 25 microns). See APPLICATION for coverage rates.		
NUMBER OF COMPONENTS	One		
PACKAGING	55 gallon (208.2L) drums, 5 gallon (18.9L) pails and 1 gallon (3.79L) cans.		
NET WEIGHT PER GALLON*	77	12.83 ± 0.25 lbs (5.92 ± .11 kg)	
	77W	12.70 ± 0.25 lbs (5.88 ± .11 kg)	
	78	12.11 ± 0.25 lbs (5.61 ± .11 kg)	
STORAGE TEMPERATURE	Minimum 20°F (-7°C)	Maximum 110°F (43°C)	
TEMPERATURE RESISTANCE	(Dry) Continuous 200°F (93°C)	Intermittent 250°F (121°C)	
SHELF LIFE	24 months at recommended storage temperature.		
FLASH POINT - SETA	65°F (18°C)		

Published technical data and instructions are subject to change without notice. The online catalog at www.tnemec.com should be referenced for the most current technical data and instructions or you may contact your Tnemec representative for current technical data and instructions.

© December 11, 2006, by Tnemec Company, Inc.



TECHNICAL DATA continued

HEALTH & SAFETY Paint products contain chemical ingredients which are considered hazardous. Read container label warning and Material Safety Data Sheet for important health and safety information prior to the use of this product. **Keep out of the reach of children.**

APPLICATION

CAUTION! Dry overspray can be wiped or washed from most surfaces. Satisfactory dry-fall performance depends upon height of work, weather conditions, equipment adjustment and proper thinning. Test for each application as follows: Spray from 15 to 25 feet towards paint container. The material then should readily wipe off. **Note:** Heat can fuse-dry overspray to surfaces. Always clean dry overspray from hot surfaces before fusing occurs. Be aware that exterior surface temperatures can be higher than air temperature.

COVERAGE RATES*

	Dry Mils (Microns)	Wet Mils (Microns)	Sq Ft/Gal (m ² /Gal)
Suggested	2.5 (65)	4.5 (115)	372 (34.6)
Minimum	2.0 (50)	3.5 (90)	465 (43.2)
Maximum	3.5 (90)	6.0 (150)	266 (24.7)

Allow for overspray and surface irregularities. Wet film thickness is rounded to the nearest 0.5 mil or 5 microns. Application of coating below minimum or above maximum recommended dry film thicknesses may adversely affect coating performance.

MIXING Stir thoroughly, making sure no pigment remains on the bottom of the can.

THINNING Use No. 2 Thinner. For air spray, thin up to 9% per gallon. For airless spray, brush or roller, thin up to 4% per gallon.

SURFACE TEMPERATURE Minimum 40°F (4°C) Maximum 120°F (49°C)
The surface should be dry and at least 5°F (3°C) above the dew point.

APPLICATION EQUIPMENT

Air Spray

Gun	Fluid Tip	Air Cap	Air Hose ID	Mat'l Hose ID	Atomizing Pressure	Pot Pressure
DeVilbiss JGA	E	765 or 704	5/16" or 3/8" (7.9 or 9.5 mm)	3/8" or 1/2" (9.5 or 12.7 mm)	75-90 psi (5.2-6.2 bar)	10-20 psi (0.7-1.4 bar)

Low temperatures or longer hoses require higher pot pressure.

Airless Spray

Tip Orifice	Atomizing Pressure	Mat'l Hose ID	Manifold Filter
0.015"-0.019" (380-485 microns)	2700-3000 psi (186-207 bar)	1/4" or 3/8" (6.4 or 9.5 mm)	60 mesh (250 microns)

Use appropriate tip/atomizing pressure for equipment, applicator technique and weather conditions.

Roller: Use high quality synthetic woven nap covers. Short nap for smooth surfaces. Long nap for rough surfaces.

Brush: Recommended for small areas only. Use high quality nylon or synthetic bristle brushes.

CLEANUP Flush and clean all equipment immediately after use with the recommended thinner or xylol.

*Values may vary with color.

WARRANTY & LIMITATION OF SELLER'S LIABILITY: Tnemec Company, Inc. warrants only that its coatings represented herein meet the formulation standards of Tnemec Company, Inc. THE WARRANTY DESCRIBED IN THE ABOVE PARAGRAPH SHALL BE IN LIEU OF ANY OTHER WARRANTY, EXPRESSED OR IMPLIED, INCLUDING BUT NOT LIMITED TO, ANY IMPLIED WARRANTY OF MERCHANTABILITY OR FITNESS FOR A PARTICULAR PURPOSE. THERE ARE NO WARRANTIES THAT EXTEND BEYOND THE DESCRIPTION ON THE FACE HEREOF. The buyer's sole and exclusive remedy against Tnemec Company, Inc. shall be for replacement of the product in the event a defective condition of the product should be found to exist and the exclusive remedy shall not have failed its essential purpose as long as Tnemec is willing to provide comparable replacement product to the buyer. NO OTHER REMEDY (INCLUDING, BUT NOT LIMITED TO, INCIDENTAL OR CONSEQUENTIAL DAMAGES FOR LOST PROFITS, LOST SALES, INJURY TO PERSON OR PROPERTY, ENVIRONMENTAL INJURIES OR ANY OTHER INCIDENTAL OR CONSEQUENTIAL LOSS) SHALL BE AVAILABLE TO THE BUYER. Technical and application information herein is provided for the purpose of establishing a general profile of the coating and proper coating application procedures. Test performance results were obtained in a controlled environment and Tnemec Company makes no claim that these tests or any other tests, accurately represent all environments. As application, environmental and design factors can vary significantly, due care should be exercised in the selection and use of the coating. **FOR INDUSTRIAL USE ONLY.**

Hi-Build Epoxoline II SERIES N69

Series V69 conforms with air pollution regulations limiting Volatile Organic Compounds (VOC) to a maximum of 250 grams/litre (2.08 lbs/gal) In areas requiring less than 100 grams/litre VOC, please refer to the Series L69 data sheet.

PRODUCT PROFILE

GENERIC DESCRIPTION	Polyamidoamine Epoxy
COMMON USAGE	An advanced generation epoxy for protection and finishing of steel and concrete. It has excellent resistance to abrasion and is suitable for immersion as well as chemical contact exposure. Contact your local Tnemec representative for a list of chemicals. This product can also be used for lining storage tanks that contain demineralized, deionized or distilled water.
COLORS	Refer to Tnemec Color Guide. Note: Epoxies chalk with extended exposure to sunlight. Lack of ventilation, incomplete mixing, miscatalyzation or the use of heaters that emit carbon dioxide and carbon monoxide during application and initial stages of curing may cause yellowing to occur.
FINISH	Satin
SPECIAL QUALIFICATIONS	A two-coat system at 4.0-6.0 dry mils (100-150 dry microns) per coat passes the performance requirements of MIL-C-4556E for fuel storage.
PERFORMANCE CRITERIA	Extensive test data available. Contact your Tnemec representative for specific test results.

COATING SYSTEM

PRIMERS	Steel: Self-priming or Series 1, 27, 37H, 66, 90, 91-H ₂ O, 94-H ₂ O, 135, 161, 394, 530 Galvanized Steel and Non-Ferrous Metal: Self-priming or Series 66, 161 Concrete: Self-priming or 54-660, 130, 218, 219 CMU: Self-priming or 54-562, 54-660, 130, 216, 218, 219
TOPCOATS	46H-413, 66, L69, N69, 73, 84, 104, 113, 114, 161, 1070, 1071, 1072, 1074, 1074U, 1075, 1075U, 1077, 1078. Refer to COLORS on applicable topcoat data sheets for additional information. Note: The following recoat times apply for Series N69/V69: Immersion Service—Surface must be scarified after 60 days. Atmospheric Service—After 60 days, scarification or an epoxy tie-coat is required. Contact your Tnemec representative for specific recommendations.

SURFACE PREPARATION

STEEL	Immersion Service: SSPC-SP10/NACE 2 Near-White Blast Cleaning Non-Immersion Service: SSPC-SP6/NACE 3 Commercial Blast Cleaning
PRIMED STEEL	Immersion Service: Scarify the Series 66, N69/V69 or 161 prime coat surface by abrasive blasting with fine abrasive before topcoating if it has been exterior exposed for 60 days or longer and N69/V69 is the specified topcoat.
GALVANIZED STEEL & NON-FERROUS METAL	Surface preparation recommendations will vary depending on substrate and exposure conditions. Contact your Tnemec representative or Tnemec Technical Services.
CAST/DUCTILE IRON	Contact your Tnemec representative or Tnemec Technical Services.
CONCRETE	Allow new concrete to cure 28 days. For optimum results and/or immersion service, abrasive blast referencing SSPC-SP13/NACE 6, ICRI CSP 2-4 Surface Preparation of Concrete and Tnemec's Surface Preparation and Application Guide.
CMU	Allow mortar to cure for 28 days. Level protrusions and mortar spatter.
PAINTED SURFACES	Non-Immersion Service: Ask your Tnemec representative for specific recommendations.
ALL SURFACES	Must be clean, dry and free of oil, grease, chalk and other contaminants.

TECHNICAL DATA

VOLUME SOLIDS*	67.0 ± 2.0% (mixed)				
RECOMMENDED DFT	2.0 to 10.0 mils (50 to 255 microns) per coat. Note: MIL-C-4556E applications require two coats at 4.0-6.0 mils (100-150 microns) per coat. Otherwise, the number of coats and thickness requirements will vary with substrate, application method and exposure. Contact your Tnemec representative.				
CURING TIME AT 5 MILS DFT Without 44-700 Accelerator	Temperature	To Handle	To Recoat	Immersion	
	90°F (32°C)	4 hours	7 hours	6 days	
	80°F (27°C)	5 hours	8 hours	7 days	
	70°F (21°C)	7 hours	10 hours	7 days	
	60°F (16°C)	8 hours	12 hours	9 days	
	50°F (10°C)	12 hours	16 hours	12 days	
VOLATILE ORGANIC COMPOUNDS*	N69: Unthinned	Thinned 10% No. 4 Thinner	Thinned 10% No. 60 Thinner	V69: Unthinned	Thinned 2.5%
	2.40 lbs/gallon (285 grams/litre)	2.80 lbs/gallon (334 grams/litre)	2.80 lbs/gallon (335 grams/litre)	1.95 lbs/gallon (234 grams/litre)	2.08 lbs/gallon (250 grams/litre)
HAPS	2.40 lbs/gal solids	3.25 lbs/gal solids	2.40 lbs/gal solids	2.00 lbs/gal solids	2.30 lbs/gal solids
THEORETICAL COVERAGE*	1,074 mil sq ft/gal (26.4 m ² /L at 25 microns). See APPLICATION for coverage rates.				
NUMBER OF COMPONENTS	Two: Part A and Part B				
PACKAGING	5 gallon (18.9L) pails and 1 gallon (3.79L) cans — Order in multiples of 2.				

Published technical data and instructions are subject to change without notice. The online catalog at www.tnemec.com should be referenced for the most current technical data and instructions or you may contact your Tnemec representative for current technical data and instructions.

© April 17, 2007, by Tnemec Company, Inc.

N69



TECHNICAL DATA continued

NET WEIGHT PER GALLON*	N69: 13.67 ± 0.25 lbs (6.10 ± .11 kg) (mixed) V69: 14.01 ± 0.25 lbs (6.36 ± .11 kg) (mixed)		
STORAGE TEMPERATURE	Minimum 20°F (-7°C)	Maximum 110°F (43°C)	
TEMPERATURE RESISTANCE	(Dry) Continuous 250°F (121°C)	Intermittent 275°F (135°C)	
SHelf LIFE	Part A: 24 months; Part B: 12 months at recommended storage temperature.		
FLASH POINT - SETA	N69 & V69 Part A: 82°F (28°C)	N69 Part B: 93°F (34°C)	V69 Part B: 86°F (30°C)
HEALTH & SAFETY	Paint products contain chemical ingredients which are considered hazardous. Read container label warning and Material Safety Data Sheet for important health and safety information prior to the use of this product. Keep out of the reach of children.		

APPLICATION

COVERAGE RATES*

	Dry Mils (Microns)	Wet Mils (Microns)	Sq Ft/Gal (m ² /Gal)
Suggested (1)	6.0 (150)	9.0 (230)	179 (16.6)
Minimum	2.0 (50)	3.0 (75)	537 (49.9)
Maximum	10.0 (250)	15.0 (375)	107 (10.0)

(1) Note: Roller or brush application requires two or more coats to obtain recommended film thickness. Also, Series N69 can be spray applied to an optional high-build film thickness range of 8.0 to 10.0 dry mils (205 to 255 dry microns) or 11.5 to 14.5 wet mils (209 to 370 wet microns). Allow for overspray and surface irregularities. Film thickness is rounded to the nearest 0.5 mil or 5 microns. Application of coating below minimum or above maximum recommended dry film thicknesses may adversely affect coating performance.

MIXING

1. Start with equal amounts of both Parts A & B.
2. Using a power mixer, separately stir Parts A & B.
3. (For accelerated version. If not using 44-700, skip to No. 4.)
Add four (4) fluid ounces of 44-700 per gallon of Part A while Part A is under agitation.
4. Add Part A to Part B under agitation, stir until thoroughly mixed.
5. Both components must be above 50°F (10°C) prior to mixing. For application of the unaccelerated version to surfaces between 50°F to 60°F (10°C to 16°C) or the accelerated version to surfaces between 35°F to 50°F (2°C to 10°C), allow mixed material to stand 30 minutes and restir before using.
6. For optimum application properties, the material temperature should be above 60°F (16°C).

Note: The use of more than the recommended amount of 44-700 will adversely affect performance.

POT LIFE

Without 44-700	15 hours at 50°F (10°C)	5 hours at 77°F (25°C)	3 hours at 100°F (38°C)
With 44-700	8 hours at 35°F (2°C)	4 hours at 77°F (25°C)	1 hour at 100°F (38°C)

THINNING

Use No. 4 or No. 60 Thinner. For air spray, thin up to 10% or ¼ pint (380 mL) per gallon. For airless spray, roller or brush, thin up to 5% or ¼ pint (190 mL) per gallon. **Note:** When using Series V69, a maximum of 2.5% of No. 4 Thinner may be used to comply with VOC regulations.

SURFACE TEMPERATURE

Minimum 50°F (10°C) Maximum 135°F (57°C)
The surface should be dry and at least 5°F (3°C) above the dew point. Coating will not cure below minimum surface temperature.

APPLICATION EQUIPMENT

Air Spray †

Gun	Fluid Tip	Air Cap	Air Hose ID	Mat'l Hose ID	Atomizing Pressure	Pot Pressure
DeVilbiss JGA	E	765 or 704	5/16" or 3/8" (7.9 or 9.5 mm)	3/8" or 1/2" (9.5 or 12.7 mm)	75-100 psi (5.2-6.9 bar)	10-20 psi (0.7-1.4 bar)

Low temperatures or longer hoses require higher pot pressure.

Airless Spray †

Tip Orifice	Atomizing Pressure	Mat'l Hose ID	Manifold Filter
0.015"-0.019" (380-485 microns)	3000-4800 psi (207-330 bar)	1/4" or 3/8" (6.4 or 9.5 mm)	60 mesh (250 microns)

Use appropriate tip/atomizing pressure for equipment, applicator technique and weather conditions.

† Spray application of first coat on CMU should be followed by backrolling.

Note: Application over inorganic zinc-rich primers: Apply a wet mist coat and allow tiny bubbles to form. When bubbles disappear in 1 to 2 minutes, apply a full wet coat at specified mil thickness.

Roller: Use 3/8" or 1/2" (9.5 mm or 12.7 mm) synthetic woven nap roller cover.

Brush: Recommended for small areas only. Use high quality natural or synthetic bristle brushes.

CLEANUP

Flush and clean all equipment immediately after use with the recommended thinner or MEK.

*Values may vary with color.

WARRANTY & LIMITATION OF SELLER'S LIABILITY: Tnemec Company, Inc. warrants only that its coatings represented herein meet the formulation standards of Tnemec Company, Inc. THE WARRANTY DESCRIBED IN THE ABOVE PARAGRAPH SHALL BE IN LIEU OF ANY OTHER WARRANTY, EXPRESSED OR IMPLIED, INCLUDING BUT NOT LIMITED TO, ANY IMPLIED WARRANTY OF MERCHANTABILITY OR FITNESS FOR A PARTICULAR PURPOSE. THERE ARE NO WARRANTIES THAT EXTEND BEYOND THE DESCRIPTION ON THE FACE HEREOF. The buyer's sole and exclusive remedy against Tnemec Company, Inc. shall be for replacement of the product in the event a defective condition of the product should be found to exist and the exclusive remedy shall not have failed its essential purpose as long as Tnemec is willing to provide comparable replacement product to the buyer. NO OTHER REMEDY (INCLUDING, BUT NOT LIMITED TO, INCIDENTAL OR CONSEQUENTIAL DAMAGES FOR LOST PROFITS, LOST SALES, INJURY TO PERSON OR PROPERTY, ENVIRONMENTAL INJURIES OR ANY OTHER INCIDENTAL OR CONSEQUENTIAL LOSS) SHALL BE AVAILABLE TO THE BUYER. Technical and application information herein is provided for the purpose of establishing a general profile of the coating and proper coating application procedures. Test performance results were obtained in a controlled environment and Tnemec Company makes no claim that these tests or any other tests, accurately represent all environments. As application, environmental and design factors can vary significantly, due care should be exercised in the selection and use of the coating. **FOR INDUSTRIAL USE ONLY.**

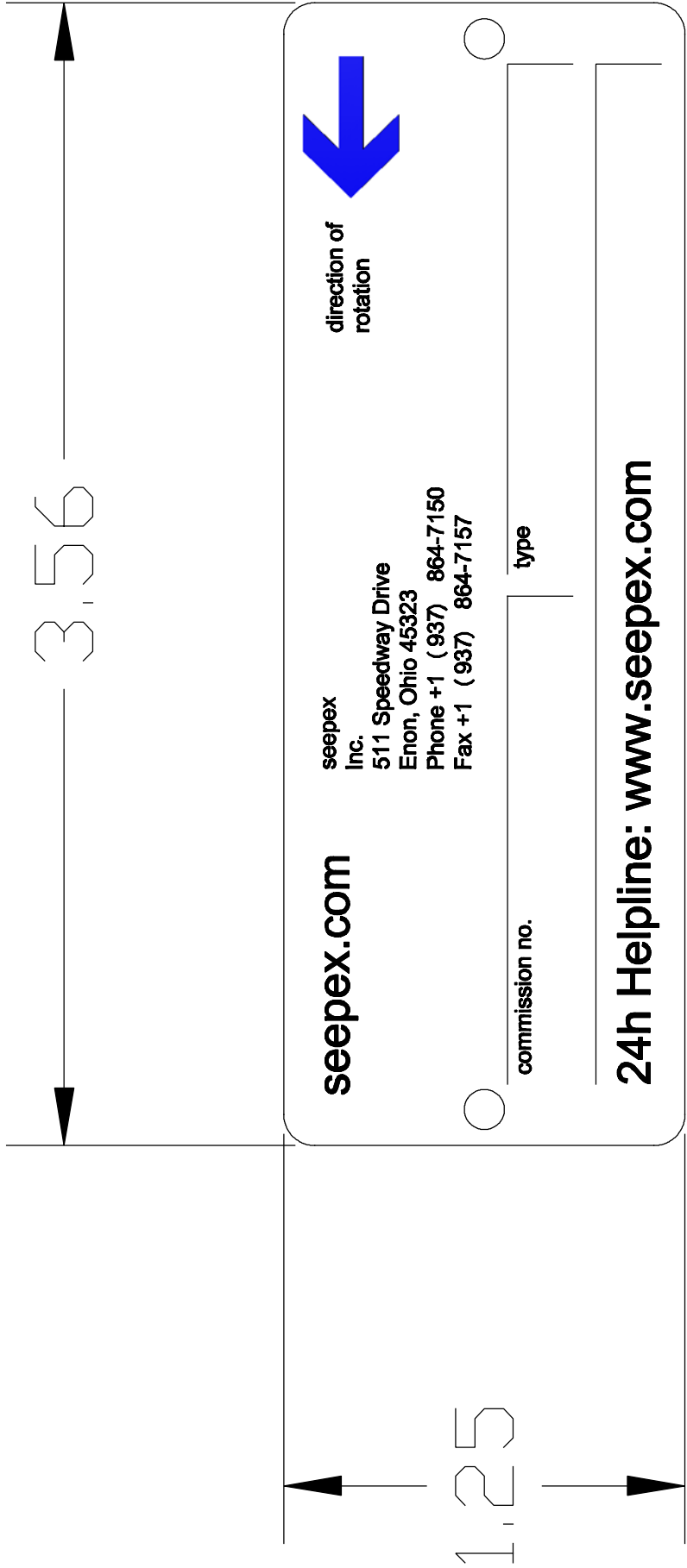

The rotor and its principle of operation.

Rotors from seepex, as the rotating core of our pumps, are as individual as your pumping process. Along with the various basic geometries, it is the material qualities, the different coatings and the surface grades that make seepex rotors what they are: individually adapted, high-quality components for your specific application. Moreover, all of our geometries are interchangeable, often without changing the dimensions of the pump. As a result, our pumps have the flexibility to adapt for changes in your pumping process.

The optimum rotor surface

The high demands for performance, efficiency and resistance to erosion that we place on our rotors can only be met by surfaces of the highest quality. State-of-the-art machining, cutting and coating processes create the optimum surfaces (up to RA 0.3) for your conveying liquid. It is possible, for instance, to reduce surface roughness by means of various grinding and polishing techniques that allow for the shape of the rotor. The wear and corrosion behavior as well as the friction and strength properties of our rotors can be specifically improved by such treatments.

Optimum service life

Coating the rotor surfaces makes a significant difference to the service life of the rotor, especially when it is used to convey abrasive products.

The chrome-based plating we supply, which is based on the ductile coating procedure, has definite advantages over conventional hard chrome.

The electrolytic process achieves pore-free and fissure-free hard coatings with outstanding hardness with a minimum of 1250 HV. Diffusion into the basic material creates an excellent bond between the basic material and the coating, and prevents peeling even under extreme operating conditions. This ensures long service life for the coating and the rotor.

Key advantages

- Optimum efficiency due to optimum surface treatment
- Saves energy by reducing the starting and operating torque
- Quiet operation characteristics due to reduced surface roughness
- Long service life due to harmonized components, cost savings on spare parts

seepex design

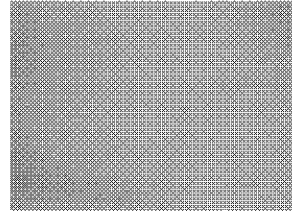

Ground and polished rotor surface

Industry standard

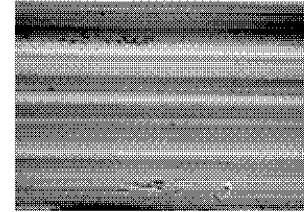

Rotor surface, peeled

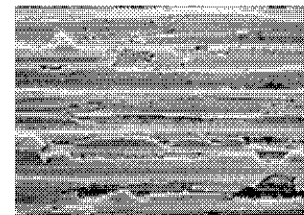

Rotor surface, ground

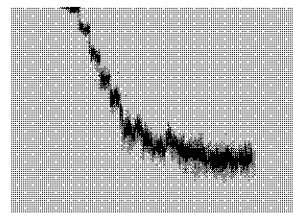

This diagram shows the advantageous deep diffusion zone of the ductile coating in the basic material, which ensures outstanding service life.

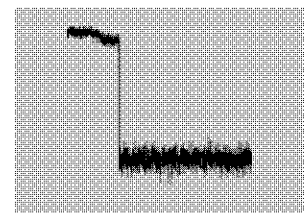

The boundary line between base material (below) and standard chrome coating (above) can be clearly distinguished. When the component is under mechanical stress stripping of the coating can occur.

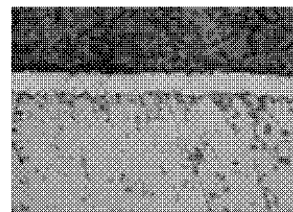

Bending test of a ductile hard chrome coating. Adhesion to the basic material is excellent, there are no cracks.

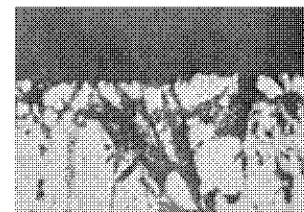

Bending test of a standard hard chrome coating. Poor adhesion, large parts of the coating have come loose.



Flat test of a ductile hard coating, polished and completely fissure free. The hardness of the ductile coating is 1620 HV, that of the basic material is 180 HV.

1. Important notice

This instruction gives details on how to plan the electrical connection and adjustment of the trip temperature. For further information and prior to commissioning it is important that the complete operating and maintenance instructions for the pump are strictly observed.



2. Electrical connection

Electrical connection has to be effected acc. to the following diagram. Prior to installation, the voltage indicated on the TSE-controller has to be compared with the existing supply voltage.

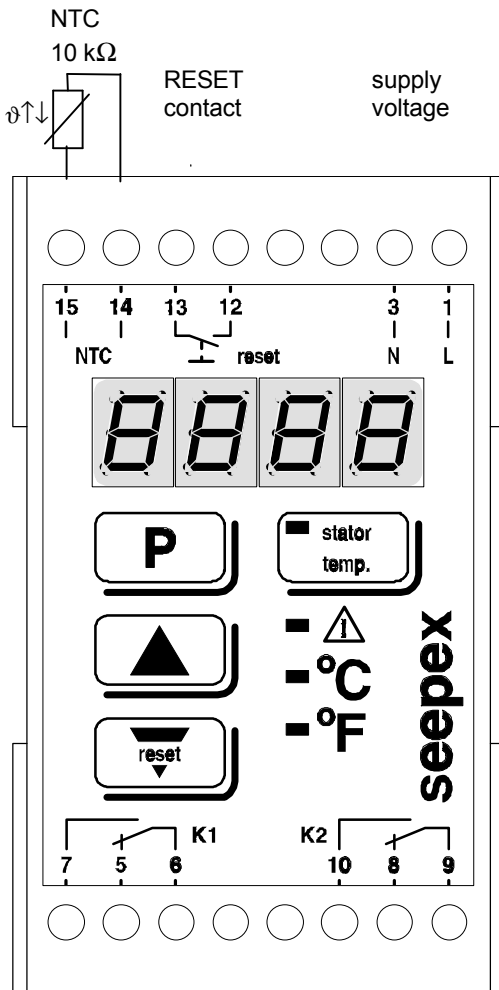

Important: function of contacts K1/K2:
actual temperature < shutdown temperature (troublefree operation)
contact 6-7 and 9-10 closed
contact 6-5 and 9-8 open

actual temperature > shutdown temperature (trouble/dry running)
contact 6-5 and 9-8 closed
contact 6-7 and 9-10 open

3. Adjustment of trip temperature

The TSE-controller is supplied with a trip temperature set at 50 °C. To achieve the shortest possible switch-off time at dry running and to have optimum pump stator protection, the trip temperature of the TSE-controller should be set as low as possible. When commissioning, the set temperature of 50°C should not be changed. Only when operating with higher product temperatures must the set point be adjusted to 20 - 30 °C above the product temperature.

Procedure:
Switching-on control voltage!
When self-testing the TSE-controller, the display shows the actual set trip temperature

 press and release button: adjusting mode is activated. The display shows alternately „SET“ and the last set trip temperature.

 Increasing the trip temperature - press button and release:
The adjusted temperature increases by +1°. Press button and hold approx. 3 sec. in +10° steps.

 Decreasing of trip temperature - press button and release:
The adjusted temperature decreases by -1°. Press button and hold approx. 3 sec. in -10° steps.

 press and release button: returns the unit to the operating mode.
The adjusted trip temperature is transferred to a continuous memory and shown on the display.

Notice During the adjusting mode if a button is not pressed within 10 seconds the controller automatically returns to the operating mode and disregards any previous adjustments.

Following the above instructions the **seepex** pump has to be in operation for at least 30 minutes to allow the operating temperature in the stator to become stable. While the pump is in operation, the measured temperature of the pump is shown on the display of the TSE-controller by continuous pressing of the

button. 

The final trip temperature has now to be adjusted 5-10°C higher than the indicated operating temperature.

The Dry Running Protection TSE

Patented

This **seepex** developed accessory, suitable for use on all **seepex** progressive cavity pumps, patent No. 2311770, provides the only universal solution that positively

protects against dry running damage, the most common cause of failure in progressive cavity pumps.

Pump cross section with TSE

- 1 Rotor
- 2 Stator
- 3 Sensor sleeve with thermistor
- 4 Connection head

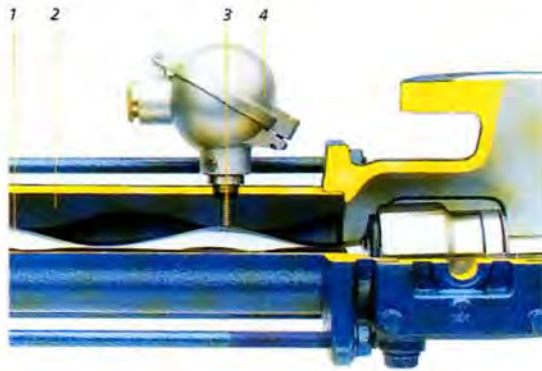

Function

The temperature between rotor and stator is continually monitored by a thermoelectronic sensor installed in the pump stator. This temperature is compared with the adjustable temperature setting on the TSE control unit.

If the pump runs dry, the temperature rises due to the increased friction between rotor and stator. Once the set point is reached, the TSE control unit stops the pump drive and activates an alarm signal.

Reliable

Destruction of the pump stator by dry running is caused by excessive friction and temperature on the surface of the stator elastomer, due to the loss of lubrication of the pumped fluid.

It is exactly this temperature, measured at its most critical point and the rise to a value which would have a destructive effect on the stator, that is avoided by a timely shutdown of the pump.

Universal Use

TSE operation is independent of the pipe condition and the kind of pump installation. It safely functions not only with water but also with products which are abrasive, highly viscous, sticky or tend to coat or clog other types of devices.

The TSE measures the variable that causes stator damage, heat, and not indirect functions such as pressure or capacitance. It is the only universal solution for dry run damage.

The TSE control unit (with isolated relay contacts) is integrated within the starter of the pump motor and is connected to the temperature sensor, installed in the **seepex** pump. The maximum admissible temperature is adjusted at the potentiometer.

A red LED malfunction signal is activated if the temperature gets too high. It remains until the manual 'Reset' function is engaged and then a green 'Run' LED is activated.

Operating voltage:

220 -240 V / 50-60Hz (standard)
110/48/24 V / 50-60Hz (special)
24 VDC (special)

TSE controller as a chassis design for inclusion into the customer's motor or pump control center.



Special design:

Sensor circuit with installation of intrinsically safe 'Zener' barriers for use of the TSE in hazardous areas.

Complete pump operating panel with the TSE in IP55 (NEMA 4) enclosure, suitable for wall mount or inclusion onto cart mounted pump units.

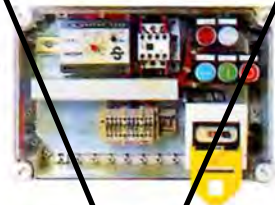

In addition to the TSE control unit, protective motor contactor, an 'On/Off/Reset' button and signal lamps for 'In operation' and 'Dry run' are installed, wired on terminal strips. For installation, only the power supply, electric motor and temperature sensor have to be connected.

The TSE is also available with a connection for a pressure switch to protect the same **seepex** positive displacement pump from 'Deadhead' operation for overpressure. A shutdown due to overpressure is indicated by a separate signal lamp, until the manual 'Reset' is activated.

Pumpen-Baugröße / pump size		1) HD-Stator mit Alu-Gussmantel (gleichmäßige Wandstärke) HD Stator with a helical cast jacket of aluminium (equal wall)				
025-12	1-12	10-12	17-12	70-12	130-12	300-6L
025-24	1-24	10-24	17-24	70-18	130-18	300-12T
05-12	2-6L	10-48	17-48	70-24	240-12	
05-24	2-12	14-12	26-12	70-48		
1-6L	2-24	17-6L	35-6L	100-18	240-6C	300-24TV
3-6LT	5-6L	26-6L	35-12	130-6L	240-9C	300-27TH
15-6LT	5-12		35-24	200-6L	240-12C	400-3TN
8-12T	5-24		35-48	200-12T	240-12L	400-6TR
	5-48		52-6L	202-6L	240-18L	400-6TR
	10-6L		52-12		300-3TR	400-12TR
	15-12T		70-6L		300-9TR	400-18TU
	30-6LT		100-6L		300-12TR	400-3LA
	40-6LT		110-12T		300-12TU	500-6LA
					300-18TU	
Pos. item	656					
Type	F8-30	F10-40	F10-45	F10-60	F10-70	F10-85
Øf	M8	M10	M10	M10	M10	M10
L	30	40	45	60	70	85
Pos. item	655					
Größe size	Ø5xØ3x5					
Pos. item	654					
Größe size	M6x10					
Øe	3.2					
Pos. item	653					
Größe size	GF1-37	GF1-45	GF1-50	GF1-65	GF1-75	GF1-90
ØD	3	3	3	3	3	3
L	37	45	50	65	75	90
Pos. item	652					
ØD	Ø19.9-0.1					
ØG	G3/8"					
Pos. item	651					
Größe size	Ø16x15					
Pos. item	650					
Type	BUZ					
ØD	20.1+0.2					

Elektrischer Anschluß siehe TSE-Betriebs- und Montageanleitung
Electric connection see TSE operating and assembly instructions

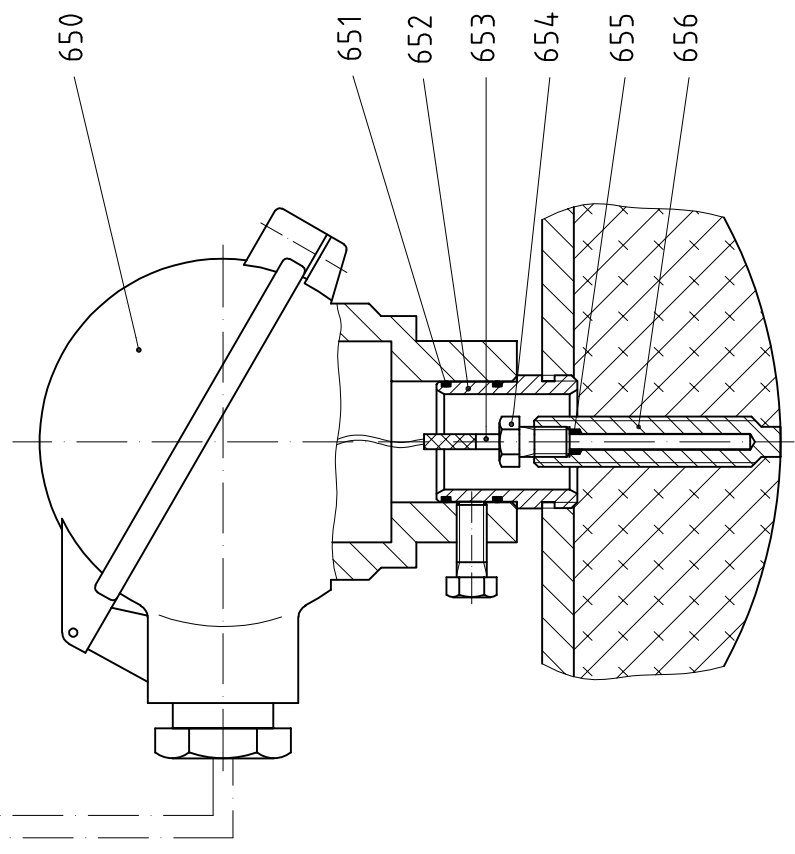

seepex.com

Stück Unit	Norm Standard	Pos./Item	Bearbeitung/Denomination Zeichnungs-Nummer/Drawing-Number	Werkstoff/Material	Bemerkung/Remark	Gewicht Weight kg
Algemeintoleranzen für Maße ohne einzelne Toleranzangabe DIN ISO 2768- <u>average</u>		Auß-Änderung Nachtrag	Name hof	Datum 08.10.1996	Maßstab/Scale 1:1	
General tolerances for dimensions without individual tolerance entry DIN ISO 2768- <u>average</u>		D Nachtrag	Name hof	Datum 06.01.1999	Bezeichnung/Denomination	
		E Baugrößen	Name hof	Datum 19.04.2000	TSE - pumpenseitige Teile	
		F Baugrößen	Name hof	Datum 13.05.2002	TSE - pumpsided parts	
		G Baugrößen	Name hof	Datum 08.01.2003	für elastische Statoren / for elastic stators	
		H Baugrößen	Name hof	Datum 18.05.2004		
Rauheit für Oberflächenzeichen DIN ISO 1302 Reihe 2		Bearbeitet/Drawn	Name hof	Datum 13.06.1996	Zeichnungs-Nummer/Drawing-Number 702-000/0000-0-008H3	
Roughness for surface finish indication DIN ISO 1302 Reihe 2		Geprüft/Checked	Name wgr	Datum 18.06.1996	EDV-Nr./EDP-No. T1800.dwg	
		Normiert/Standard	Name		Ersatz für/Replacement for	
		Gedruckt/Printed	Name		A 2429-4	

Urheberrechtsschutz: Diese Zeichnung ist unser Eigentum und uns nach dem Gesetz über Urheberrecht und verwandte Schutzrechte geschützt.
Protection of Copyright: This drawing is our property and is protected acc. to the law referring to copyright and related protective laws.

Stck.	Pos.	DE	EN	FR
		Baureihe BN	Range BN	Série BN
		Schnittzeichnung Nr. 062-004_1	sectional drawing no. 062-004_1	plan no. 062-004_1
		Benennung Stck. / Pos.	denomination Qty. / Item	désignation Qté. / Poste
1	200	Laterne	lantern	lanterne
2	202	Halbrundkerbnägel	round head grooved pins	rivet
1	203	Typenschild	type plate	palque signalitique
4	210	6kt-Schraube	hexagon bolt	vis
	211	6kt-Schraube	hexagon bolt	vis
4	212	Federring	spring washer	rondelle frein
4	213	6kt-Mutter	hexagon nut	écrou
1	307	Steckwelle	plug-in shaft	arbre à broche
1	309	Steckwellenbolzen	plug-in shaft pin	cheville pour arbre à broche
1	310	Spritzring	splash ring	bague de projection
1	400	Kuppelstange	coupling rod	barre d' accouplement
2	401	Gelenkhülse	retaining sleeve	douille d' articulation
2	402	Kuppelstangenbolzen	coupling rod pin	axe d' articulation
4	403	Führungsbuchse	guide bushing	douille de guidage
2	404	Kuppelstangenbuchse	coupling rod bushing	chemise d' axe
2	405	Manschette	universal joint sleeve	manchette
2	406	Halteband	holding band	collier de serrage
2	407	Halteband	holding band	collier de serrage
1	500	Sauggehäuse	suction casing	carter d' aspiration
1	501	Sauggehäusedichtung	casing gasket	étanchéité du carter d' aspiration
3	502	Verschlusschraube	screwed plug	bouchon de vidange
3	503	Dichtring	sealing ring	joint d' étanchéité
4	506	6kt-Schraube	hexagon bolt	vis
4	507	Fächerscheibe	fan type lock washer	rondelle à dents chevauchantes extérieures
4	509	6kt-Mutter	hexagon nut	écrou
2	°) 510	Reinigungsdeckel	cleanout	couvercle de nettoyage
2	°) 511	Dichtung	gasket	étanchéité
8	°) 512	6kt-Schraube	hexagon bolt	vis
2	°) 516	Verschlusschraube	screwed plug	bouchon de vidange
2	°) 517	Dichtring	sealing ring	joint d' étanchéité
1	600	Rotor	rotor	rotor
1	601	Stator	stator	stator
2	602	Spannschraube	tie bolt	tirant
2	603	Spannschraube	tie bolt	tirant
8	604	6kt-Mutter	hexagon nut	écrou
8	606	Scheibe	washer	rondelle
1	607	Stützbock	trestle	ped
1	700	Druckstutzen	pressure branch	bride de refoulement
1	705	Verschlusschraube	screwed plug	bouchon de vidange
1	706	Dichtring	sealing ring	joint d' étanchéité

		DE	EN	FR
		Baureihe BN	Range BN	Série BN
		Schnittzeichnung Nr. 062-004_1	sectional drawing no. 062-004_1	plan no. 062-004_1
Stck.	Pos.	Benennung Stck. / Pos.	denomination Qty. / Item	désignation Qté. / Poste
	098	seepex Gelenkfett Typ und Füllmenge: Betriebs- und Wartungsanleitung entnehmen	seepex joint grease type and filling quantity: see Operating and Maintenance Instruction	seepex graisse d' articulations sommaire pour type et quantité: voir Instructions de service et d'entretien
		Verschleißteile und Dichtungen: Betriebs- und Wartungsanleitung entnehmen	Wear parts and sealings: see Operating and Maintenance Instruction	pièces d'usure et étanchéités: voir Instructions de service et d'entretien
		Werkzeuge: Betriebs- und Wartungsanleitung entnehmen	Tools: see Operating and Maintenance Instruction	Outils: voir Instructions de service et d'entretien
		Wellenabdichtung siehe Schnittzeichnung Gleitringdichtung	shaft sealing see sectional drawing mechanical seal	dispositif d' etanchéité voir vue éclatée garniture mécanique
		versetzt gezeichnet	drawn displaced	plan séparé
	°)	Option	option	option

Cartex® Single pusher cartridge seals



Features

- Single seal
- Cartridge
- Balanced
- Independent of direction of rotation
- Single seals without connections (-SNO), with flush (-SN) and with quench combined with lip seal (-QN) or throttle ring (-TN)
- Additional variants available for ANSI pumps (e.g.-ABPN) and eccentric screw pumps (-Vario)

Advantages

- Ideal seal for standardizations
- Universal applicable for packings conversions, retrofits or original equipment
- No dimensional modification of the seal chamber (centrifugal pumps) necessary, small radial installation height
- No dynamically loaded O-Ring
- Extended service life
- Installation faults are avoided, cost-effective
- No damage caused by dirt entered during assembly
- Straightforward and easy installation due to pre-assembled unit (reduced down-times)
- Individual adaptation to pump design possible
- Customer specific versions available

Operating range (see note on page 1)

Cartex-SN, -SNO, -QN, -TN, -Vario
 Shaft diameter: $d_1 = 25 \dots 100$ mm (1.000" ... 4.000")
 Other sizes on request
 Temperature: $t = -40 \text{ °C} \dots +220 \text{ °C}$ (-40 °F ... +428 °F)
 (Check O-Ring resistance)

Sliding face material combination BQ1
 Pressure: $p_1 = 25$ bar (363 PSI)
 Sliding velocity: $v_g = 16$ m/s (52 ft/s)
 Sliding face material combination Q101 or U2Q1
 Pressure: $p_1 = 12$ bar (174 PSI)
 Sliding velocity: $v_g = 10$ m/s (33 ft/s)
 Axial movement: ± 1.0 mm, $d_1 \geq 75$ mm ± 1.5 mm

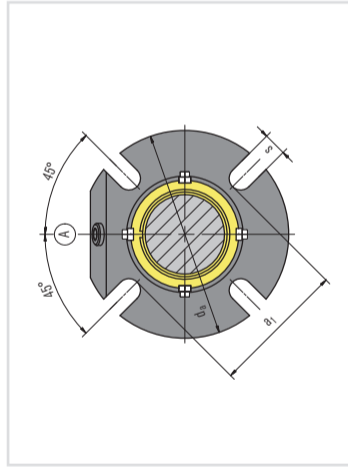
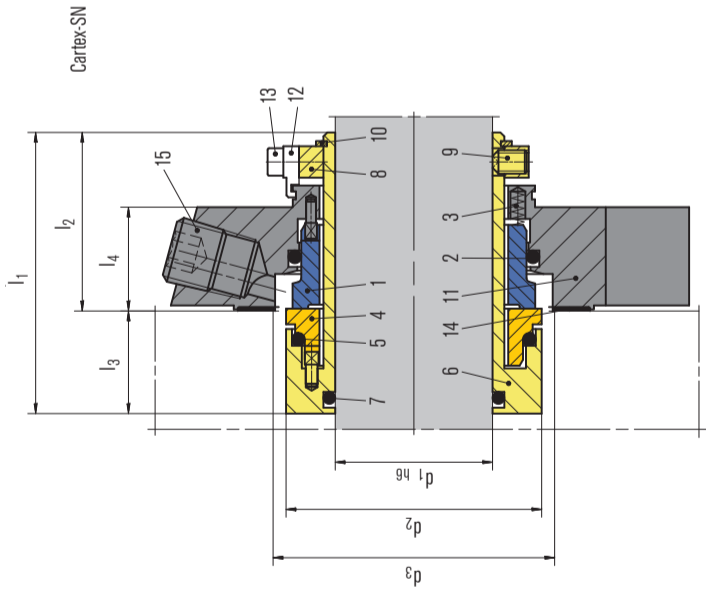

Machined cover version

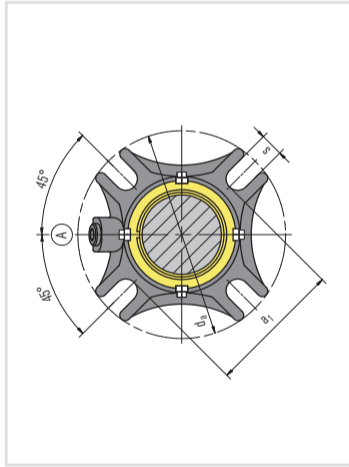

Cast cover version

Materials

Seal face: Silicon carbide (Q1), Carbon graphite resin impregnated (B), Tungsten carbide (U2)
 Seat: Silicon carbide (Q1)
 Secondary seals: FKM (V), EPDM (E), FFKM (K), Perfluorocarbon rubber/PTEE (U1)
 Springs: Hastelloy® C-4 (M)
 Metal parts: CrNiMo steel (G), CrNiMo cast steel (G)

Recommended applications

- Process technology
- Water supply and water treatment
- Chemical and petrochemical industry
- Pharmaceutical industry
- Food and beverage industry
- Universally applicable
- Centrifugal pumps
- Eccentric screw pumps
- Process pumps

Product variants

Cartex-SNO
 Single seal without connections, for dead-end operation.

Cartex-TN
 Single seal for operation with unpressurized quench. Same as Cartex-SN but with throttle ring (item 16). The cover has auxiliary connections for flushing and quench. Throttle ring: PTFE carbon-graphite reinforced.

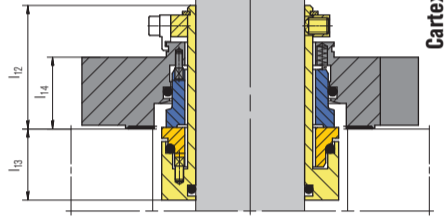

Cartex-SNO

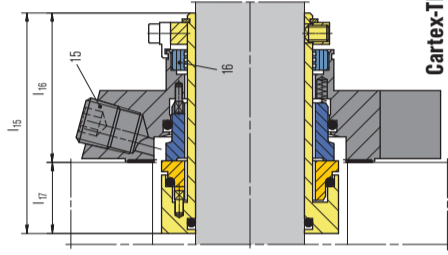

Cartex-TN

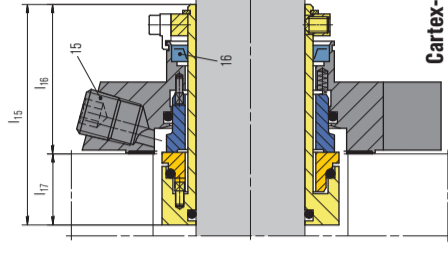

Cartex-QN



Cartex-Vario

Cartex-Vario
 Cartridge seals with modified cover for eccentric screw pumps.

For e.g. Seepex BN, Netzsch NM ... S, NM ... B, NE (P), Allweiler AE, AEB, AED, Robbins & Myers/Moyno 2000 CC and Mono E-Range. Please inquire.

Dimensions in mm

d ₁	d ₂	d _{3min.}	d _{3max.}	l ₁	l ₂	l ₃	l ₄	l ₅	l ₆	l ₇	a ₁	d ₆	s			
25	43.0	44.0	51.5	67	42.4	24.6	25.4	35.0	32.0	17.5	79.5	53.4	26.1	62	105	13.2
28	46.0	47.0	52.0	67	42.4	24.6	25.4	35.0	32.0	17.5	79.5	53.4	26.1	62	105	13.2
30	48.0	49.0	56.0	67	42.4	24.6	25.4	35.0	32.0	17.5	79.5	53.4	26.1	65	105	13.2
32	49.8	51.0	57.0	67	42.4	24.6	25.4	35.0	32.0	17.5	79.5	53.4	26.1	67	110	13.2
33	49.8	51.0	57.0	67	42.4	24.6	25.4	35.0	32.0	17.5	79.5	53.4	26.1	67	110	13.2
35	53.0	54.0	61.5	67	42.4	24.6	25.4	35.0	32.0	17.5	79.5	53.4	26.1	70	113	13.2
38	56.0	57.0	66.0	67	42.4	24.6	25.4	35.0	32.0	17.5	79.5	53.4	26.1	75	123	13.2
40	58.0	59.0	68.0	67	42.4	24.6	25.4	35.0	32.0	17.5	79.5	53.4	26.1	75	123	14.2
42	60.5	61.5	69.5	67	42.4	24.6	25.4	35.0	32.0	17.5	79.5	53.4	26.1	80	133	14.2
43	60.5	61.5	70.5	67	42.4	24.6	25.4	35.0	32.0	17.5	79.5	53.4	26.1	80	133	14.2
45	62.5	64.0	73.0	67	42.4	24.6	25.4	35.0	32.0	17.5	79.5	53.4	26.1	81	138	14.2
48	65.6	67.0	75.0	67	42.4	24.6	25.4	35.0	32.0	17.5	79.5	53.4	26.1	84	138	14.2
50	68.0	69.0	78.0	67	42.4	24.6	25.4	35.0	32.0	17.5	79.5	53.4	26.1	87	148	14.2
53	72.0	73.0	87.0	67	42.4	24.6	25.4	35.0	32.0	17.5	79.5	53.4	26.1	97	148	18.0
55	73.0	74.0	83.0	67	42.4	24.6	25.4	35.0	32.0	17.5	79.5	53.4	26.1	90	148	18.0
60	78.0	79.0	91.0	67	42.4	24.6	25.4	35.0	32.0	17.5	79.5	53.4	26.1	102	157	18.0
65	84.8	85.7	96.5	67	42.4	24.6	25.4	35.0	32.0	17.5	79.5	53.4	26.1	109	163	18.0
70	93.0	95.0	108.0	67	42.4	24.6	25.4	35.0	32.0	17.5	79.5	53.4	26.1	118	178	18.0
75	100.0	101.6	118.0	84	57.4	26.6	28.0	46.1	37.9	22.0	98.0	63.9	34.1	129	190	18.0
80	106.4	108.0	124.0	84	57.4	26.6	28.0	46.1	37.9	22.0	98.0	63.9	34.1	135	195	18.0
85	109.5	111.1	128.0	84	57.4	26.6	28.0	46.1	37.9	22.0	98.0	63.9	34.1	139	198	22.0
90	115.9	117.5	135.0	84	57.4	26.6	28.0	46.1	37.9	22.0	98.0	63.9	34.1	145	205	22.0
95	119.1	120.7	138.0	84	57.4	26.6	28.0	46.1	37.9	22.0	98.0	63.9	34.1	148	208	22.0
100	125.4	127.0	144.0	84	57.4	26.6	28.0	46.1	37.9	22.0	98.0	63.9	34.1	154	218	22.0

Dimensions in inch

d ₁	d ₂	d _{3min.}	d _{3max.}	l ₁	l ₂	l ₃	l ₄	l ₅	l ₆	l ₇	a ₁	d ₆	s			
1.000	1.693	1.750	2.008	2.640	1.669	0.969	1.000	1.378	1.260	0.689	3.130	2.102	1.028	2.441	4.134	0.520
1.125	1.811	1.850	2.047	2.640	1.669	0.969	1.000	1.378	1.260	0.689	3.130	2.102	1.028	2.441	4.134	0.520
1.250	1.969	2.008	2.244	2.640	1.669	0.969	1.000	1.378	1.260	0.689	3.130	2.102	1.028	2.640	4.252	0.520
1.375	2.087	2.126	2.421	2.640	1.669	0.969	1.000	1.378	1.260	0.689	3.130	2.102	1.028	2.756	4.449	0.520
1.500	2.205	2.244	2.589	2.640	1.669	0.969	1.000	1.378	1.260	0.689	3.130	2.102	1.028	2.953	4.843	0.520
1.625	2.344	2.375	2.700	2.640	1.669	0.969	1.000	1.378	1.260	0.689	3.130	2.102	1.028	3.031	4.843	0.559
1.750	2.461	2.520	2.874	2.640	1.669	0.969	1.000	1.378	1.260	0.689	3.130	2.102	1.028	3.189	5.433	0.559
2.000	2.677	2.717	3.071	2.640	1.669	0.969	1.000	1.378	1.260	0.689	3.130	2.102	1.028	3.307	5.433	0.559
2.125	2.855	2.875	3.425	2.640	1.669	0.969	1.000	1.378	1.260	0.689	3.130	2.102	1.028	3.425	5.827	0.559
2.250	2.961	3.000	3.560	2.640	1.669	0.969	1.000	1.378	1.260	0.689	3.130	2.102	1.028	3.940	6.181	0.709
2.375	3.071	3.110	3.563	2.640	1.669	0.969	1.000	1.378	1.260	0.689	3.130	2.102	1.028	4.016	6.181	0.709
2.500	3.213	3.250	3.800	2.640	1.669	0.969	1.000	1.378	1.260	0.689	3.130	2.102	1.028	4.173	6.417	0.709
2.625	3.339	3.338	3.937	2.640	1.669	0.969	1.000	1.378	1.260	0.689	3.130	2.102	1.028	4.291	6.417	0.709
2.750	3.661	3.740	4.252	2.640	1.669	0.969	1.000	1.378	1.260	0.689	3.130	2.102	1.028	4.646	7.008	0.709
2.875	3.937	4.000	4.646	3.307	2.260	1.047	1.100	1.815	1.492	0.866	-	-	-	5.079	7.480	0.709
3.000	3.937	4.000	4.646	3.307	2.260	1.047	1.100	1.815	1.492	0.866	3.858	2.516	1.343	5.079	7.480	0.709
3.125	4.189	4.252	4.882	3.307	2.260	1.047	1.100	1.815	1.492	0.866	3.858	2.516	1.343	5.315	7.677	0.709
3.250	4.189	4.252	4.882	3.307	2.260	1.047	1.100	1.815	1.492	0.866	-	-	-	5.315	7.677	0.709
3.375	4.431	4.374	5.039	3.307	2.260	1.047	1.100	1.815	1.492	0.866	-	-	-	5.472	7.795	0.866
3.500	4.431	4.500	5.157	3.307	2.260	1.047	1.100	1.815	1.492	0.866	-	-	-	5.591	7.795	0.866
3.625	4.563	4.626	5.315	3.307	2.260	1.047	1.100	1.815	1.492	0.866	-	-	-	5.709	8.071	0.866
3.750	4.689	4.752	5.433	3.307	2.260	1.047	1.100	1.815	1.492	0.866	3.858	2.516	1.343	5.827	8.189	0.866
4.000	4.937	5.000	5.669	3.307	2.260	1.047	1.100	1.815	1.492	0.866	-	-	-	6.063	8.653	0.866

Anordnung Spüldurchfluß
arrangement flushing
passage

Quench Auslaß
quench outlet

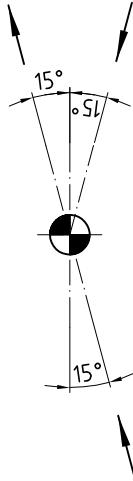

Quench Einlaß
quench inlet

Zirkulation Einlaß (bei Bedarf)
circulation inlet (if required)



Gewindestifte mit Ringschneide dürfen
nur einmal verwendet werden.
Gewindestifte gleichmäßig in mehreren
Schritten über Kreuz anziehen.
Mit Loctite Nr. 243 gesichert.
Anzugsmoment: 7 Nm
Set screws with cup point must be
used only once.
Tighten set screws equally,
crosswise, in several steps.
Secured with Loctite No. 243.
Tighten torque: 7 Nm

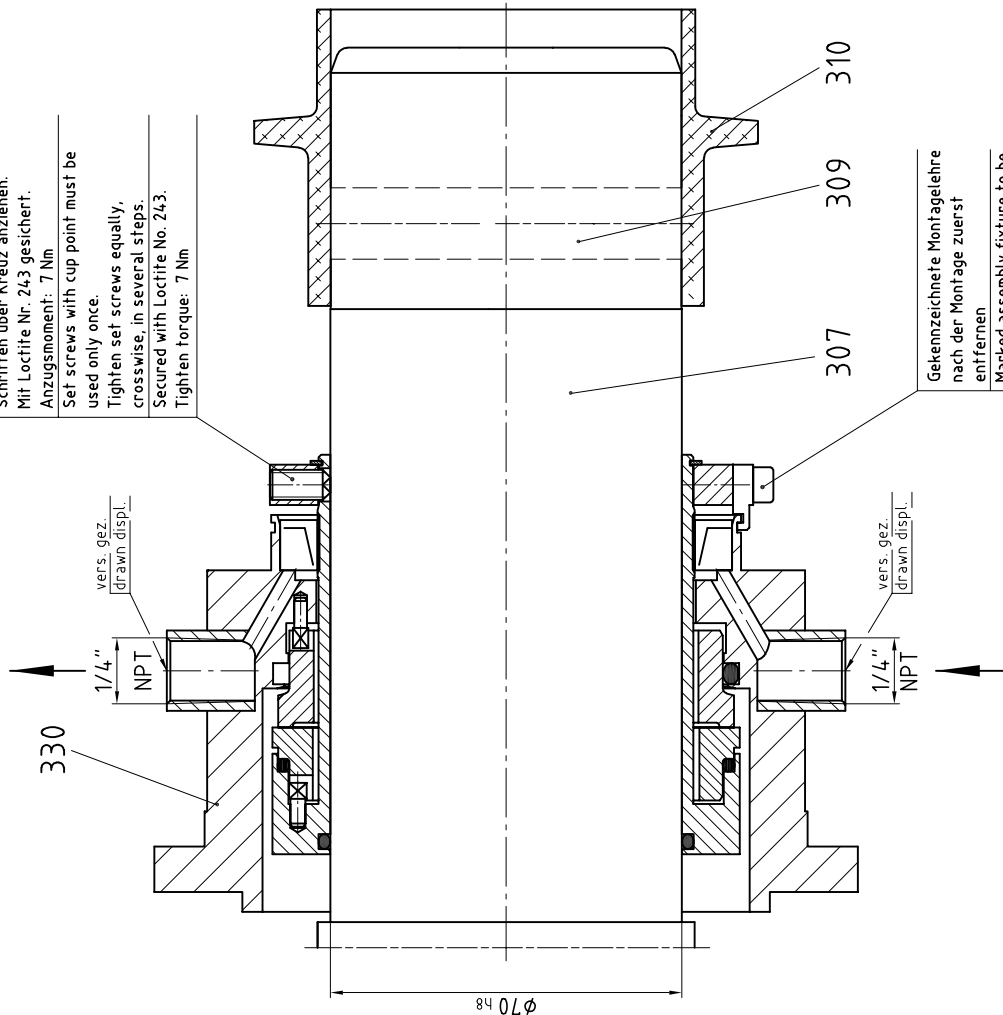

Gekennzeichnete Montagelehre
nach der Montage zuerst
entfernen
Marked assembly fixture to be
removed first after assembly

Stück Unit	Norm Standard	Pos./Item	Benennung/Denomination Zeichnungs-Nummer/Drawing-Number	Werkstoff/Material	Bemerkung/Remark	Gewicht Weight kg
1		330	GLRD / mechanical seal Cartex QES- ϕ 70		Fabrikat / make: Burgmann	
1		310	Spitztring / splash ring 062-310/0170-4-001_3			
1		309	Steckwellenbolzen / plug-in shaft pin 062-309/0170-4-001_4			
1		307	Streckwelle / plug-in shaft 262-307/0170-3-001_3			

seepex.com

Änderung Change Issue	Name Name	Datum Date	Maßstab/Scale 1:1	Werkstoff/Material	Gewicht/Weight
B Möglichkeit Possibility	tg	16.10.2007	1:1		
Bezeichnung/Denomination GLRD Schnittzeichnung mechanical seal sectional drawing Burgmann Cartex QES- ϕ 70 mit / with Quench					
Zeichnungs-Nummer/Drawing-Number 262-0GB/0170-0-112B3					
EDV-Nr./EDP-Nb. L:\LFDZ\CHNG\195\19766.dwg					
Ersatz für/Replacement for: Ersatz durch/Replacement by:					
Rauheit für Surface finish DIN ISO 1302 Reihe 2					
Name Date 19.08.1995					
Bearbeitet/Drawn hg					
Geprüft/Checked hg					
Datum Date 19.08.1995					
Normiert/Standard hg					
Gedruckt/Printed hg					
Urheberrechtsschutz: Diese Zeichnung ist unser Eigentum und uns nach dem Gesetz über Urheberrecht und verwandte Schutzrechte geschützt. Protection of Copyright: This drawing is our property and is protected acc. to the law referring to copyright and related protective laws.					

Tab 2

Pump Technical Data: BN 74/8N

seepex date	5/24/2012	commission no.	832027-832028		
customer	Weaver Construction Management - Englewood, CO				
seepex job no.	2113909	offer/item	5383/0134 item 2		
project	PO# 9103				
2 of	seepex progressive cavity pump type BN 52-6L/A1-C1-C6-R0-4E-X X=0320, 06B1, 0804, 11R0, 163, 17T,				
conveying product					U/495/SC
denomination	Digested Sludge				
rate of solids	0.01-0.3%	viscosity	ass. <500 cPs		
size of solids	no advice	pH-value	ass. 5-9		
specific gravity	ass. 1.05	temperature	0.5-23 C		
composition	no advice				
remarks					
performance data	nom.	min	max		
conveying capacity		115	230	USGPM	
pump speed		166	332	rpm	
press in press. branch		12.1	12.1	psi	
press in suct. branch	assume flooded				
differential pressure	12.1	psi	operating torque	100	lb.ft
required drive power	7.42	Hp	starting torque	259	lb.ft
remarks	Data according to performance curve				
technical pump data					
range	BN	kind of install.	horizontal		
size	52	direction of rot.	counterclockwise		
pressure stage	6L	pos. of branch	2		
component	material	design/option			
lantern	GG25 grey cast iron	standard			
suction casing	GG25 grey cast iron	suction casing with cleanouts both sides with drain plugs DN 5" ANSI B16.5 150lb.			
suction connection		DN 5" ANSI B16.5 150lb.			
pressure branch	GG25 grey cast iron				
pressure connection		DN 5" ANSI B16.5 150lb.			
joint	standard	standard			
joint grease	30321	standard			
joint seal	EPDM	standard			
coupling rod	1.4021/AISI 420	standard			
rotor	1.2436/AISI D6	standard with ductile coating			
stator	EPDM	TSE design w/ 316Ti SS sensor sleeve			
seal casing	1.4571/AISI 316 Ti	Single Acting Cartridge Seal			
seal		Burgman Cartex QN5-070-Q1Q1-EMG			
plug-in shaft	1.4021/AISI 420	drilled Φ40 x 75			
special designs	TSE pump end components including controller				

general operating data

kind of operation continuous operation 8hr day
site of installation suitable for indoor installation
remarks

drive

type Gear Box
make Nord **ratio** i=5.1
model SK42ALF-250TC-NSD **nom/ min - max**
mounting position M1(B5) **output speed** 346/ 166- 332 **rpm**
flange dia 250 mm **motor speed** 1765/ 850- 1696 **rpm**
output shaft 716/0170-002B4 **frequency** 60/ 29- 58 **Hz**
special AL bearings, NSD – Nord Severe Duty

electric motor

manufacturer WEG
model 01518ET3E254TC-W22 **voltage** 3x208-230/460 VAC
nominal power 15 Hp **rated frequency** 60 Hz
mounting position F1 (C-face, w/feet) **enclosure** TEFC
starting direct on VFD **thermal class** F
special Severe Duty, 250TC, 20:1 CT
E80- Thermostats (N.C.), E30- Space Heaters

dry running protection device

model TSE – 115 VAC **voltage** 110-115 VAC / 50/60 Hz.
delivery scope
remarks TSE with NPT connections in IP55 connection head

baseplate

standard B-ST-LS US design **material** steel
drawing no. [801-200/0520-A-144A3](#) **surface** painted
special/accessories grout holes, drain pan w/ drain connection and 3/4" NPT drain plug
baseplate extended for motor support

paint

execution standard- epoxy
color RAL 5013 (blue)
remarks surface prep carbon steel only to SSPC SP6
surface prep all to SSPC SP1
primer - Tnemec series 37H-77 - 2 - 3.5 mil dft
finish - Tnemec Series N69 Hi-Build Epoxoline II, 2 coats each 1.5 – 2.5 mil dft
stainless steel components are not to be painted

packing

packing type skid
marking 2113909

documentation

dimensional drawing no. [122738](#) **operating manual** 1 copy English
sectional drawing no. [062-004_1](#)
shaft sealing sect. view [262-0GB/0170-0-112_3](#)
remarks

additional accessories / special designs / remarks

overpressure devices

manufacturer	Onyx	series	PSW
center material	CS	center flange size	5" ANSI B16.5 150lbs RF
end plate material	derlin acetal	sleeve material	Buna
gauge			
manufacturer	Ashcroft	series	1008
diameter	4"	range	0-100 psi
pressure switch			
manufacturer	Ashcroft	model	B4 24 B
switch type	SPDT	range	0-100 psi
enclosure	NEMA 4X	set pressure	50 psi
remarks			

Proco Flex Connection – Discharge Side (Qty 1)

FA-231
 150" ANSI Drilling
 350 psi max rated @150°F max
 Single Filled Arch csnitrile mtl
 5" x 6" Expansion Joint
 w/ 150# drilled ring set & back-up flange rings

Spare Parts:

Rotor
 Stator
 Joint Assembly Kit
 Mechanical Seal

Anchor Bolts: HAS – R 316SS (qty 4 per pump)

QA Testing:

Certificate of Compliance
 Per DIN EN 10204 Type 2.1

Tag: DSP-1 and DSP-2

Copyright: This drawing is our property and patented for us according to the law of copyright and associated rights !

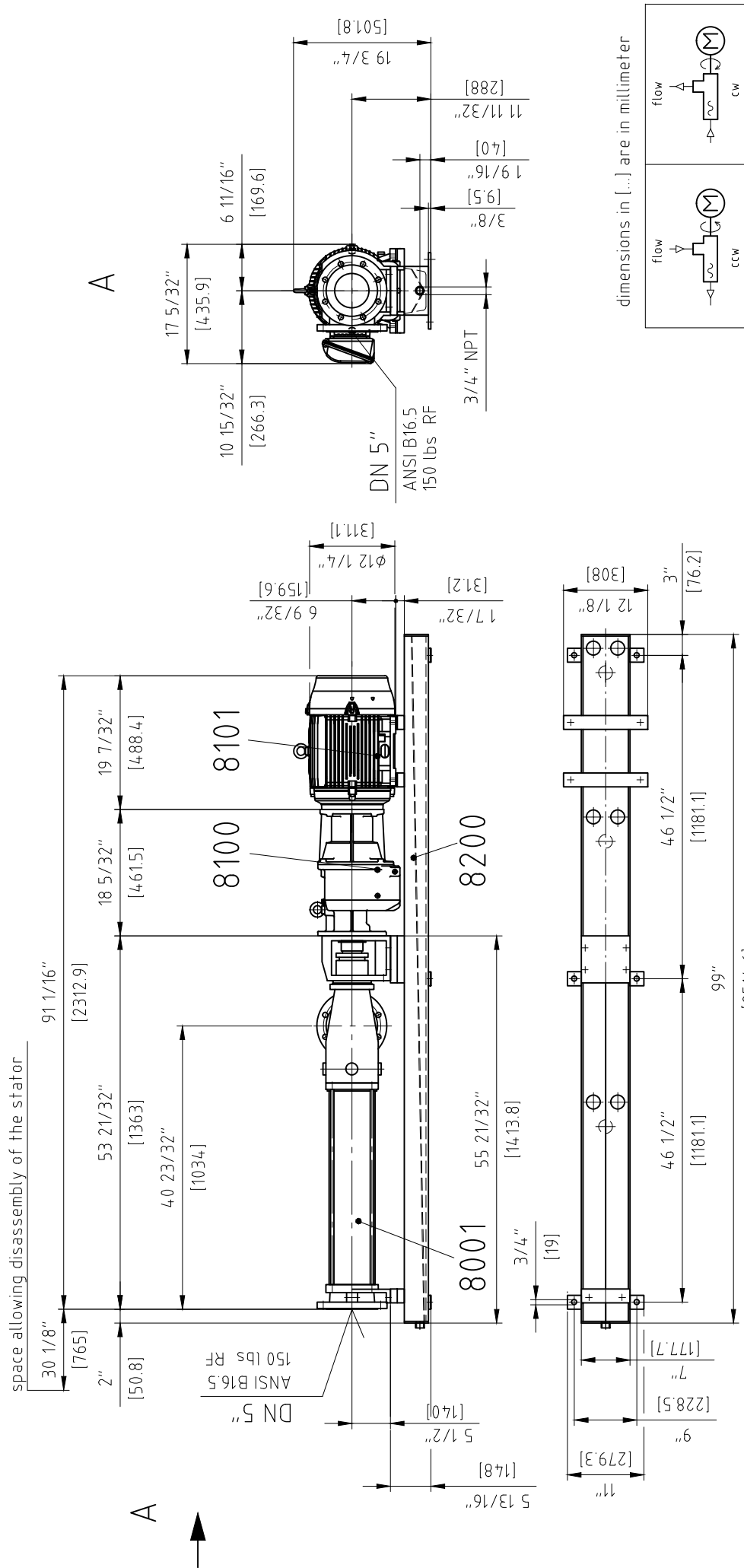

1	baseplate:	8200	Var.: 801-200/0520-A-144
1	motor: WEG 01518ET3E254TC-W22	8101	
1	gear: SK42F-250TC	8100	
1	pump: BN 52-6L/26-12	8001	
Quant.	Denomination	Item	Note
		Material	Weight
		Scale	
		Day	
		13.06.	1:20
		EDP-No.	122738.dwg
		13.06.	122738.dwg
		g0E	
		2012	
		Drawn	sbe
		Checked	g0E
		811 Speedway Drive	
		Enon, OH 45323	
		www.seeplex.com	
		2012	
		Name	
		sbe	
		13.06.	
		1:20	
		EDP-No.	122738.dwg
		13.06.	
		g0E	
		2012	
		Drawn	sbe
		Checked	g0E
		811 Speedway Drive	
		Enon, OH 45323	
		www.seeplex.com	
		2012	
		Name	
		sbe	
		13.06.	
		1:20	
		EDP-No.	122738.dwg
		13.06.	
		g0E	
		2012	
		Drawn	sbe
		Checked	g0E
		811 Speedway Drive	
		Enon, OH 45323	
		www.seeplex.com	
		2012	
		Name	
		sbe	
		13.06.	
		1:20	
		EDP-No.	122738.dwg
		13.06.	
		g0E	
		2012	
		Drawn	sbe
		Checked	g0E
		811 Speedway Drive	
		Enon, OH 45323	
		www.seeplex.com	
		2012	
		Name	
		sbe	
		13.06.	
		1:20	
		EDP-No.	122738.dwg
		13.06.	
		g0E	
		2012	
		Drawn	sbe
		Checked	g0E
		811 Speedway Drive	
		Enon, OH 45323	
		www.seeplex.com	
		2012	
		Name	
		sbe	
		13.06.	
		1:20	
		EDP-No.	122738.dwg
		13.06.	
		g0E	
		2012	
		Drawn	sbe
		Checked	g0E
		811 Speedway Drive	
		Enon, OH 45323	
		www.seeplex.com	
		2012	
		Name	
		sbe	
		13.06.	
		1:20	
		EDP-No.	122738.dwg
		13.06.	
		g0E	
		2012	
		Drawn	sbe
		Checked	g0E
		811 Speedway Drive	
		Enon, OH 45323	
		www.seeplex.com	
		2012	
		Name	
		sbe	
		13.06.	
		1:20	
		EDP-No.	122738.dwg
		13.06.	
		g0E	
		2012	
		Drawn	sbe
		Checked	g0E
		811 Speedway Drive	
		Enon, OH 45323	
		www.seeplex.com	
		2012	
		Name	
		sbe	
		13.06.	
		1:20	
		EDP-No.	122738.dwg
		13.06.	
		g0E	
		2012	
		Drawn	sbe
		Checked	g0E
		811 Speedway Drive	
		Enon, OH 45323	
		www.seeplex.com	
		2012	
		Name	
		sbe	
		13.06.	
		1:20	
		EDP-No.	122738.dwg
		13.06.	
		g0E	
		2012	
		Drawn	sbe
		Checked	g0E
		811 Speedway Drive	
		Enon, OH 45323	
		www.seeplex.com	
		2012	
		Name	
		sbe	
		13.06.	
		1:20	
		EDP-No.	122738.dwg
		13.06.	
		g0E	
		2012	
		Drawn	sbe
		Checked	g0E
		811 Speedway Drive	
		Enon, OH 45323	
		www.seeplex.com	
		2012	
		Name	
		sbe	
		13.06.	
		1:20	
		EDP-No.	122738.dwg
		13.06.	
		g0E	
		2012	
		Drawn	sbe
		Checked	g0E
		811 Speedway Drive	
		Enon, OH 45323	
		www.seeplex.com	
		2012	
		Name	
		sbe	
		13.06.	
		1:20	
		EDP-No.	122738.dwg
		13.06.	
		g0E	
		2012	
		Drawn	sbe
		Checked	g0E
		811 Speedway Drive	
		Enon, OH 45323	
		www.seeplex.com	
		2012	
		Name	
		sbe	
		13.06.	
		1:20	
		EDP-No.	122738.dwg
		13.06.	
		g0E	
		2012	
		Drawn	sbe
		Checked	g0E
		811 Speedway Drive	
		Enon, OH 45323	
		www.seeplex.com	
		2012	
		Name	
		sbe	
		13.06.	
		1:20	
		EDP-No.	122738.dwg
		13.06.	
		g0E	
		2012	
		Drawn	sbe
		Checked	g0E
		811 Speedway Drive	
		Enon, OH 45323	
		www.seeplex.com	
		2012	
		Name	
		sbe	
		13.06.	
		1:20	
		EDP-No.	122738.dwg
		13.06.	
		g0E	
		2012	
		Drawn	sbe
		Checked	g0E
		811 Speedway Drive	
		Enon, OH 45323	
		www.seeplex.com	
		2012	
		Name	
		sbe	
		13.06.	
		1:20	
		EDP-No.	122738.dwg
		13.06.	
		g0E	
		2012	
		Drawn	sbe
		Checked	g0E
		811 Speedway Drive	
		Enon, OH 45323	
		www.seeplex.com	
		2012	
		Name	
		sbe	
		13.06.	
		1:20	
		EDP-No.	122738.dwg
		13.06.	
		g0E	
		2012	
		Drawn	sbe
		Checked	g0E
		811 Speedway Drive	
		Enon, OH 45323	
		www.seeplex.com	
		2012	
		Name	
		sbe	
		13.06.	
		1:20	
		EDP-No.	122738.dwg
		13.06.	
		g0E	
		2012	
		Drawn	sbe
		Checked	g0E
		811 Speedway Drive	
		Enon, OH 45323	
		www.seeplex.com	
		2012	
		Name	
		sbe	
		13.06.	
		1:20	
		EDP-No.	122738.dwg
		13.06.	
		g0E	
		2012	
		Drawn	sbe
		Checked	g0E
		811 Speedway Drive	
		Enon, OH 45323	
		www.seeplex.com	
		2012	
		Name	
		sbe	
		13.06.	
		1:20	
		EDP-No.	122738.dwg
		13.06.	
		g0E	
		2012	
		Drawn	sbe
		Checked	g0E
		811 Speedway Drive	
		Enon, OH 45323	
		www.seeplex.com	
		2012	
		Name	
		sbe	
		13.06.	
		1:20	
		EDP-No.	122738.dwg
		13.06.	
		g0E	
		2012	
		Drawn	sbe
		Checked	g0E
		811 Speedway Drive	
		Enon, OH 45323	
		www.seeplex.com	
		2012	
		Name	
		sbe	
		13.06.	
		1:20	
		EDP-No.	122738.dwg
		13.06.	
		g0E	
		2012	
		Drawn	sbe
		Checked	g0E
		811 Speedway Drive	
		Enon, OH 45323	
		www.seeplex.com	
		2012	
		Name	
		sbe	
		13.06.	
		1:20	
		EDP-No.	122738.dwg
		13.06.	
		g0E	
		2012	
		Drawn	sbe
		Checked	g0E
		811 Speedway Drive	
		Enon, OH 45323	
		www.seeplex.com	
		2012	
		Name	
		sbe	
		13.06.	
		1:20	
		EDP-No.	122738.dwg
		13.06.	
		g0E	
		2012	

Characteristic Curves
Size
52-6L

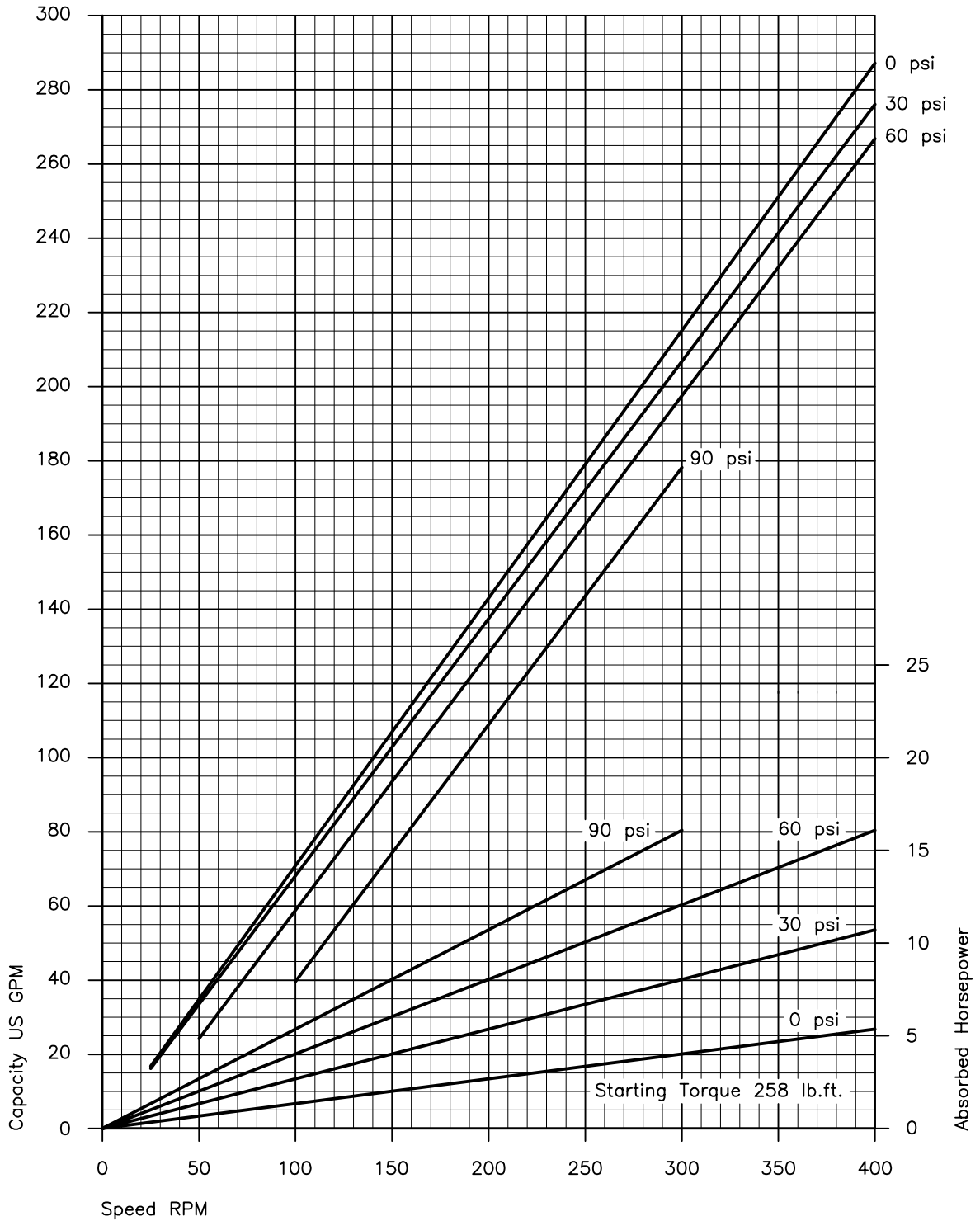

Values based upon water 68°F ; For notes on drive selection refer to PER

CHA.52-6L B 01.03us

type	constant c
0005-24	3,1076
0015-24	1,7972
003-12	1,4381
003-24	1,4229
006-12	0,9558
006-24	0,9558
01-48	0,5743
012-12	0,6144
012-24	0,6144
025-6L	0,4828
025-12T	0,6271
05-6LT	0,6837
025-12	0,3792
025-24	0,3768
05-12	0,2379
05-24	0,2306
1-6L	0,2379
1-12	0,1547
1-12V	0,1547
1-24	0,1541
1-24V	0,1541
2-6L	0,1547
2-12	0,0971
2-12V	0,0971
2-24	0,0974
2-24V	0,0974
5-6L	0,0965
5-6LS	0,0885
5-12	0,0599
5-12V	0,0599
5-24	0,0603
5-24V	0,0603
5-48	0,0603
8-12T	0,091
10-6L	0,0597
10-6LS	0,0527
10-12	0,0379
10-12V	0,0379
10-24	0,0380
10-24V	0,0380
10-48	0,0380
14-12	0,0307
15-6LT	0,1055
15-12T	0,0675
17-6L	0,0379
17-6LS	0,0362
17-12	0,0256
17-12V	0,0256
17-24	0,0257
17-24V	0,0257
17-48	0,0257
26-6L	0,0307
26-12	0,0192
30-6LT	0,0644
30-12T	0,0452
35-6L	0,0253
35-6LS	0,0247
35-12	0,0155
35-12V	0,0155
35-18	0,0156
35-24	0,0156
35-24V	0,0156
35-48	0,0156
40-6LT	0,0524

type	constant c
52-6L	0,0194
52-6LS	0,0177
52-12	0,0127
55-6LT	0,0432
55-12T	0,0278
55-24	0,0157
70-6L	0,0154
70-6LS	0,0156
70-12	0,0100
70-12V	0,0100
70-18	0,0100
70-24	0,0100
70-48	0,0100
75-6LT	0,0344
100-6L	0,0126
100-6LS	
100-18	0,0100
110-6LT	0,0277
110-12T	0,0179
130-6L	0,0099
130-6LS	0,0099
130-12	0,0066
130-12V	0,0066
130-18	0,0067
200-6L / 202-6L	0,0079
200-12T	0,0109
240-12	0,0045
300-6L	0,0057
300-12T	0,0082

BN 52-6L
0.0194X230=4.462

BIG sizes

type	constant c
240-6C	0,0045
240-9C	0,0045
240-12C	0,0045
240-12L	0,0045
240-18L	0,0045
240-24C	0,0044
240-24D	0,0045
300-3TR	0,0082
300-9TR	0,0082
300-12TR	0,0082
300-12TU	0,0082
300-18TU	0,0082
300-24TV	0,0082
300-27TH	0,0082
400-3TN	0,0061
400-6TN	0,0061
400-6TR	0,0061
400-12TR	0,0061
400-18TU	0,0061
500-3LA	0,0045
500-6LA	0,0045

Derivation of the NPSH value:

Faktor = Q × c

Q capacity US GPM

c constant

Take NPSH value depending on the calculated factor from NPSH curve (refer to sheet 2) and add a 1,5ft safety margin.

NPSH = f (Faktor) + 1,5ft

NPSH = f (Faktor) sheet 2

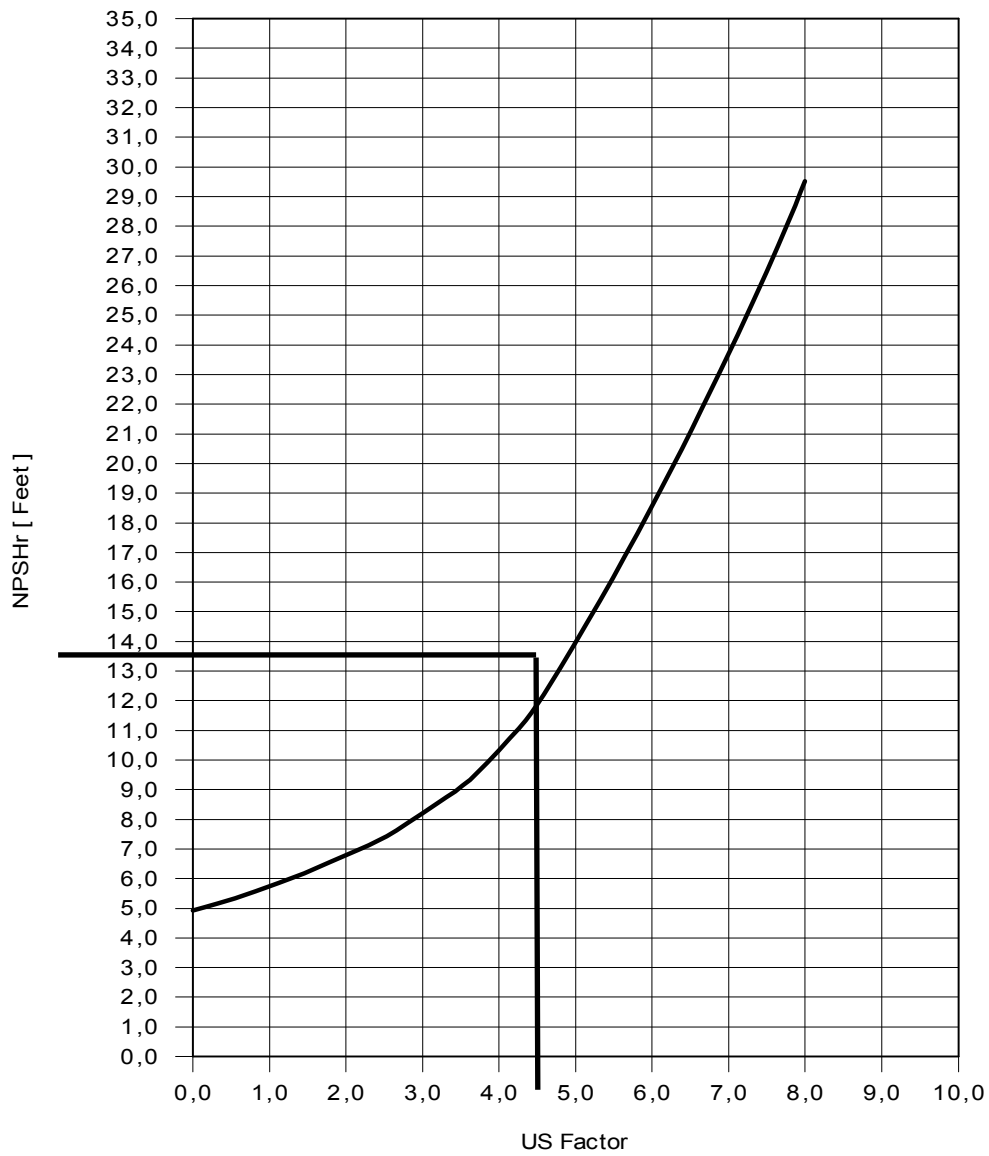



HELICAL IN-LINE

PERFORMANCE SPECIFICATIONS

Configuration: concentric
 Integral motor HP (min./ max.): 0.16 / 200
 Integral motor kW (min./ max.): 0.12 / 160
 Typical efficiency: 98.5%
 # of gear reductions: 1 to 6

MOUNTING STYLES

Footed housing style: standard
 B5 flange outside diameter range [in]: 4.72 to 21.65
 B5 flange outside diameter range [mm]: 120 to 550
 B14 flange outside diameter range [in]: 3.54 to 7.87
 B14 flange outside diameter range [mm]: 90 to 200

OPTIONS

Custom adapter flange
 Flange pilot removed

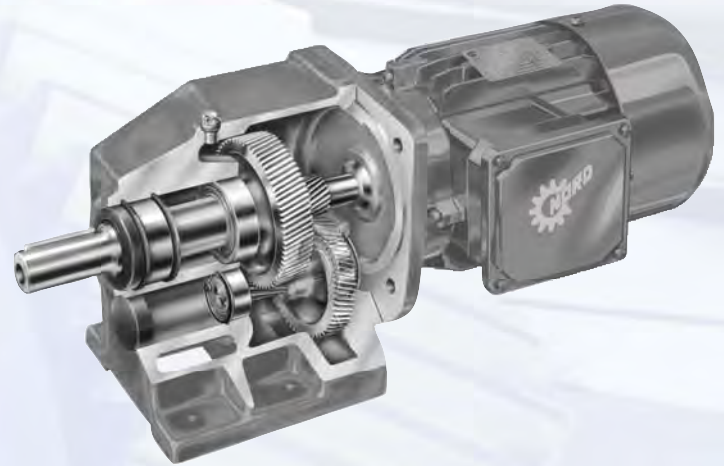

RATIO AND SPEED

Minimum standard ratio: 1.24:1
 Maximum standard ratio: 13304.45:1
 Minimum output speed from 1750 rpm motor: 0.13 rpm
 Maximum output speed from 1750 rpm motor: 1411 rpm

Unit Size	Torque Max.		Ratio Range Min.Max.	Shaft Diameter		Unit Size	Torque Max.		Ratio Range Min.Max.	Shaft Diameter	
	[lb-in]	[Nm]		[in]	[mm]		[lb-in]	[Nm]		[in]	[mm]
SK 02	876	99	2.95 - 73.06	0.750	20	SK 51	4,354	492	1.24 - 13.27	1.625	40
SK 03	974	110	65.50 - 313.11	0.750	20	SK 52	17,912	2,024	2.78 - 86.92	2.250	55
SK 11	513	58	1.35 - 9.11	1.000	20	SK 53	19,753	2,232	58.94 - 728.20	2.250	55
SK 12	1,628	184	2.96 - 72.63	1.000	25	SK 62	27,612	3,120	2.97 - 48.73	2.500	65
SK 13	1,717	194	68.40 - 420.83	1.000	25	SK 63	32,745	3,700	17.37 - 372.21	2.500	65
SK 21	681	77	1.46 - 10.20	1.250	25	SK 72	41,666	4,708	2.76 - 43.71	3.000	75
SK 22	3,310	374	2.79 - 86.30	1.250	30	SK 73	50,003	5,560	18.00 - 205.61	3.000	75
SK 23	3,009	340	64.80 - 516.65	1.250	30	SK 82	64,127	7,246	2.89 - 48.82	3.500	90
SK 31	1,637	185	1.33 - 10.20	1.625	30	SK 83	81,243	9,180	21.04 - 216.61	3.500	90
SK 32	6,284	710	2.96 - 81.27	1.625	40	SK 92	93,359	10,775	3.51 - 35.47	4.250	110
SK 33	5,947	672	88.18 - 740.37	1.625	40	SK 93	123,900	14,000	19.12 - 187.89	4.250	110
SK 41	2,567	290	1.41 - 14.80	1.375	35	SK 102	153,698	17,367	4.28 - 38.81	5.250	130
SK 42	11,009	1,244	3.02 - 105.08	1.875	45	SK 103	204,966	23,160	21.19 - 207.47	5.250	130
SK 43	11,497	1,299	40.98 - 1071.82	1.875	45						

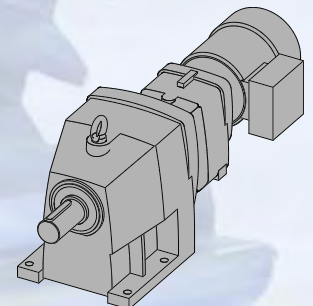
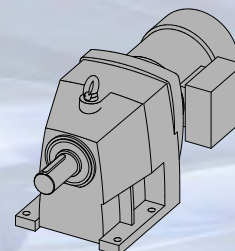
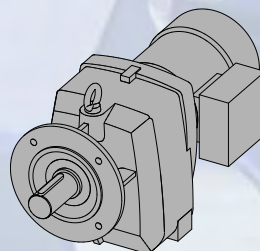
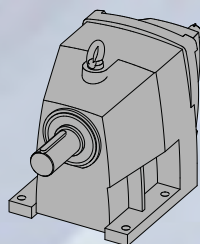
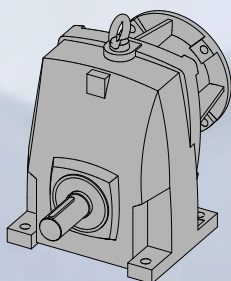



SHAFT DATA

Input and output shaft material:ASI 1045 or 4140
 Input and output shaft key dimensions [in]:according to ANSI B17
 Input and output shaft key dimensions [mm]:according to DIN 747
 Output shaft drill and tap:standard

OPTIONS

Custom shaft diameters
 Custom spline
 Cross drilled holes
 304 stainless steel

MOTOR MOUNTING

Integral motor:1/6 to 250 HP
 C-face adapter frame size range:56C to 360TC
 IEC adapter (B5) frame size range:IEC 63 to IEC 315
 Sugar scoop motor availability:56 to 365T
 Top mount platform motor availability:56 to 405T

OPTIONS

Custom motor adapter
 Custom coupling diameter

GEARING

Quality rating on gears:up to AGMA Class 13
 Minimum hardness of steel gears:58 Rockwell C
 Hard finishing of gear teeth:grinding or skive hob
 Drop forged gear blanks:standard
 Momentary overload capacity:275%
 Hunting tooth ratios:standard

HOUSING

Typical housing material:Class 35 gray iron
 Machining method:single setup
 Main housing design:UNICASE™ one piece
 Seal carrier:direct to main housing
 Housing torsional stiffness:exceptional
 Housing wall section:thick
 Casting sealing method:dip seal

BEARINGS

Bearing quality:ABEC-1
 Standard output bearing:ball or spherical
 Heavy-duty output bearing:heavy-duty spherical

INTERNAL PARTS ASSEMBLY

Assembly method:heavy press fit
 Reversing duty:standard
 Typical backlash range [arc minutes]:10 to 17

LUBRICANT AND SEALING COMPONENTS

Factory filled lubricant type:ISO 220 mineral oil
 Typical breather vent style:AUTOVENT
 Output seal design:QUADRILIP™ Seal System
 Output shaft oil seals:1 double lip and 1 single lip
 oil seal lip material:nitrile rubber
 Oil seal to housing gasket:nitrile rubber

OPTIONS

Custom synthetic lubricating oil
 Custom temperature lubricating oil
 Fluid grease lubricant
 Food grade lubricating oil
 Long term storage preparation
 Magnetic drain plug
 Bullseye sight glass
 Custom drain plug
 Fluorinated rubber oil seal material
 Custom oil seals

ENVIRONMENTAL PROTECTION

Exterior primer coverage:all metal exterior surfaces
 Paint type:Water Based Resin
 Paint additive:316 stainless steel flakes
 USDA incidental contact exposure:H1

OPTIONS

NSD+ protection • custom paint
 High pressure washdown IP66 oil seals:custom order
 Shaft seal covers:custom order

MECHANICAL VARIABLE SPEED COMPATIBILITY

HP range with TITAN™ belt box:0.33 to 150
 Speed range with TITAN™ belt box:8.9 to 1308
 HP range with NORDISC®traction drive:0.25 to 7.5
 Speed range with NORDISC®traction drive:0.5 to 1621



www.nord.com

NORD Gear Corporation

National Customer Service Toll-Free: 888.314.6673
 info@nord-us.com

NORD Gear Limited

Toll-Free in Canada: 800.668.4378
 info@nord-ca.com

WEST

Corona, CA (Los Angeles)
 Phone: 608.849.0190

MIDWEST

Wauwaukee, WI (Madison)
 Phone: 608.849.7300

EAST

Charlotte, NC
 Phone: 608.849.0140

CANADA

Brampton, ON (Toronto)
 Phone: 905.796.3606



STANDARD REDUCER FEATURES

QUADRILIP™ shaft seal system – consisting of 2 spring compression lips, 1 trash guard lip and 1 collector grease pack – keeps contaminants out and lubricant inside the gear case.

AUTOVENT breather seals dirt and moisture out while allowing the gear case to breathe during startup and cool down.

Standard paint has 316 stainless steel flakes with a flexible and tough resin binder. USDA incidental contact H1 approval provides excellent moisture and corrosion resistance.

Primer paint covers all exterior surfaces of the housing, providing excellent base corrosion protection.

Housing interior seal coating locks in casting sand, fills in processing blemishes eliminating leak paths, and protects against moisture damage to inside of gear case.

UNICASE™ one-piece housing is torsionally stiff, machined in one pass, has extreme accuracy, and eliminates the split case leakage path.

Shaft material is wear-resistant, high carbon steel that provides stable non-grooving surface for oil seal contact.

Outside diameter of oil seals is nitrile rubber. Direct connection of seal to housing eliminates bolt-on covers and centers the seal, eliminating the potential for leakage.

Grease Filled Pockets

Plunge Ground Surface (No Spiral) To 12:20 RMS

Double Seals, 3 Sealing Lips

Labyrinth

Sealing Ring

O-Ring



Helical Speed Reducers

Double reduction, for assembly with NEMA C-face motors

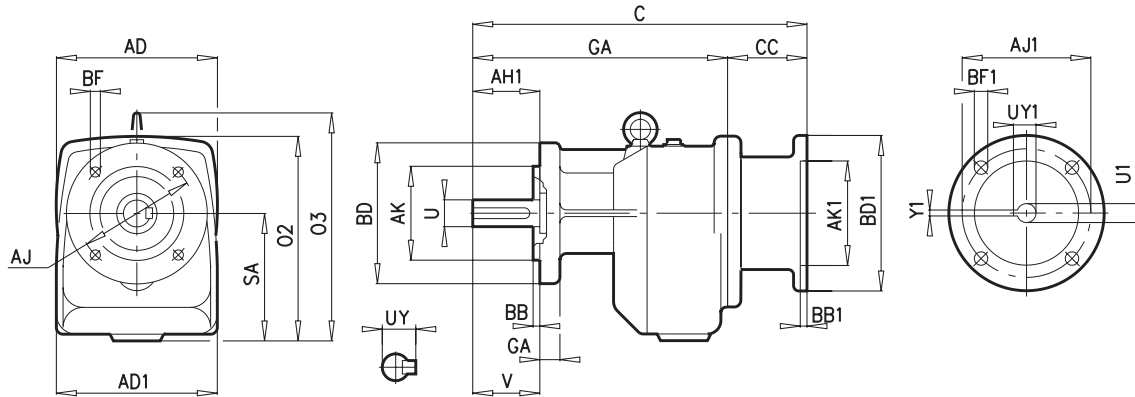
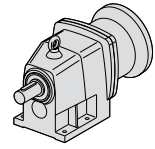

Type	Mounting dimensions (flange)			Outline dimensions								
	AJ	BB	BF	AD	AD1	AH1	C	CC	O2	O3	QA	SA
SK 02 F - 56 C	5.12	0.14	0.35	5.12	5.12	1.50	11.59	4.50	6.77	—	7.09	3.50
- 140 TC	4.331	6.30	0.39				11.59	4.50	6.77			
SK 12 F - 56 C	5.12	0.14	0.35	5.12	5.32	2.13	12.73	4.50	7.44	—	8.23	4.17
- 140 TC							12.73	4.50	7.44			
- 180 TC	4.331	6.30	0.39				13.88	5.65	8.70			
SK 22 F - 56 C	6.50	0.14	0.43	7.87	7.28	2.75	14.40	4.60	8.86	—	9.80	4.92
- 140 TC							14.40	4.60	8.86			
- 180 TC	5.118	7.87	0.47				16.40	6.60	9.45			
SK 32 F - 56 C	8.46	0.16	0.55	7.87	8.27	3.25	16.47	4.60	10.04	11.50	11.87	6.10
- 140 TC							16.47	4.60	10.04			
- 180 TC	7.087	9.84	0.63				18.47	6.60	10.63			
- 210 TC							18.47	6.60	10.63			
SK 42 F - 56 C	8.46	0.16	0.55	9.84	8.47	3.50	18.08	4.30	11.81	12.87	13.78	6.89
- 140 TC							18.08	4.30	11.81			
- 180 TC	7.087	9.84	0.63				21.68	7.90	11.81			
- 210 TC							21.68	7.90	11.81			
- 250 TC							21.68	7.90	11.81			
SK 52 F - 56 C	10.43	0.16	0.55	9.84	10.24	4.00	20.11	4.30	13.27	15.16	15.81	8.35
- 140 TC							20.11	4.30	13.27			
- 180 TC	9.055	11.81	0.79				23.71	7.90	13.27			
- 210 TC							23.71	7.90	13.27			
- 250 TC							23.71	7.90	13.27			
- 280 TC							24.35	8.54	13.27			



NEMA	AJ1	AK1	BB1	BD1	BF1	U1	UY1	Y1
56 C	5.88	4.500	0.16	6.54	0.43	0.625	0.71	0.188
140 TC	5.88	4.500	0.16	6.54	0.43	0.875	0.96	0.188
180 TC	7.25	8.500	0.23	9.17	0.59	1.125	1.24	0.250
210 TC	7.25	8.500	0.23	9.17	0.59	1.375	1.52	0.312
250 TC	7.25	8.500	0.23	9.17	0.59	1.625	1.80	0.375
280 TC	9.00	10.500	0.23	13.78	0.59	1.875	2.10	0.500

Shaft dimensions	SK 02 F	SK 12 F	SK 22 F	SK 32 F	SK 42 F	SK 52 F
U	0.750	1.000	1.250	1.625	1.875	2.250
UY	0.83	1.11	1.36	1.79	2.09	2.47
V	1.50	2.13	2.75	3.25	3.50	4.00
Key	3/16 x 3/16 x 1-1/4	1/4 x 1/4 x 1-5/8	1/4 x 1/4 x 2-1/4	3/8 x 3/8 x 2-3/4	1/2 x 1/2 x 2-3/4	1/2 x 1/2 x 3-1/4

Additional flange sizes available	SK 02 F	SK 12 F	SK 22 F	SK 32 F	SK 42 F	SK 52 F
AJ	3.94 / 4.53	3.94 / 4.53	5.12	6.50	6.50	8.46
AK	3.150 / 3.740	3.150 / 3.740	4.331	5.118	5.118	7.087
BB	0.12 / 0.12	0.12 / 0.12	0.14	0.14	0.14	0.16
BD	4.72 / 5.51	4.72 / 5.51	6.30	7.87	7.87	9.84
BF	0.28 / 0.35	0.28 / 0.35	0.35	0.43	0.43	0.55
GA	0.39 / 0.39	0.39 / 0.39	0.39	0.47	0.55	0.63

Technical design may be subject to change. DXF files available upon request.

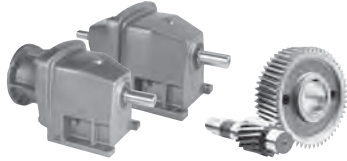

SK 41E , SK 42 NEMA-C + W Ratings & Combinations



Model Type	Gear Ratio	Output Speed n_2 1750 rpm [rpm]	Output Torque* T_{2max} [lb-in]	Maximum input power [◇] Solid input shafts type "W"				NEMA C-Face* Available Combinations								
				Input Speed				56C	140TC	180TC	210TC	250TC	280TC	320TC	360TC	
				1750 rpm [hp]	1150 rpm [hp]	875 rpm [hp]	580 rpm [hp]									
SK 41E	1.41	1241	1593	20.00	13.20	10.00	6.60			X	X	X				
	1.50	1167	1682	20.00	13.20	10.00	6.60			X	X	X				
	1.63	1074	1770	20.00	13.20	10.00	6.60			X	X	X				
	1.82	962	1974	20.00	13.20	10.00	6.60	X	X	X	X	X				
	2.14	818	2195	20.00	13.20	10.00	6.60	X	X	X	X	X				
	2.50	700	2398	20.00	13.20	10.00	6.60	X	X	X	X	X				
	3.08	568	2567	20.00	13.20	10.00	6.60	X	X	X	X	X				
	3.42	512	1239	10.07	6.64	5.03	3.32	X	X	X	X					
	3.88	451	1283	9.18	6.06	4.59	3.03	X	X	X	X*					
	4.29	408	1372	8.88	5.86	4.44	2.93	X	X	X	X*					
	5.27	332	1726	9.09	6.00	4.55	3.00			X	X*					
	7.18	244	1682	6.51	4.30	3.25	2.15			X	X*					
	10.55	166	1682	4.43	2.92	2.21	1.46	X	X	X*						
	14.80	118	1177	2.20	1.45	1.10	0.73	X	X							
SK 42	3.02	579	5345	20.00	13.20	10.00	6.60			X	X	X				
	3.21	545	5487	20.00	13.20	10.00	6.60			X	X	X				
	3.50	500	5885	20.00	13.20	10.00	6.60			X	X	X				
	3.89	450	6195	20.00	13.20	10.00	6.60	X	X	X	X	X				
	4.58	382	6832	20.00	13.20	10.00	6.60	X	X	X	X	X				
	4.79	365	8196	20.00	13.20	10.00	6.60			X	X	X				
	5.10	343	8708	20.00	13.20	10.00	6.60			X	X	X				
	5.35	327	7230	20.00	13.20	10.00	6.60	X	X	X	X	X				
	5.75	304	10036	20.00	13.20	10.00	6.60			X	X	X				
	6.19	283	9514	20.00	13.20	10.00	6.60	X	X	X	X	X				
	6.65	263	10293	20.00	13.20	10.00	6.60			X	X	X				
	7.28	240	9523	20.00	13.20	10.00	6.60	X	X	X	X	X				
	8.50	206	9523	20.00	13.20	10.00	6.60	X	X	X	X	X				
	10.20	172	10328	20.00	13.20	10.00	6.60	X	X	X	X	X				
	12.28	143	10585	20.00	13.20	10.00	6.60	X	X	X	X	X				
	14.38	122	10248	19.84	13.09	9.92	6.55	X	X	X	X	X*				
	15.12	116	11009	20.00	13.20	10.00	6.60	X	X	X	X	X				
	17.71	99	10496	16.49	10.88	8.24	5.44	X	X	X	X	X*				
	17.92	98	8832	13.73	9.06	6.87	4.53			X	X					
	21.50	81	10293	13.23	8.73	6.61	4.37			X	X					
	21.87	80	9700	12.31	8.13	6.16	4.06	X	X	X	X	X*				
24.41	72	7593	8.67	5.73	4.34	2.86			X	X*						
24.67	71	7885	8.88	5.86	4.44	2.93	X	X	X	X*						
25.88	68	11001	11.87	7.83	5.93	3.92			X	X						
29.29	60	9036	8.60	5.68	4.30	2.84			X	X*						
30.46	57	9540	8.63	5.69	4.31	2.85	X	X	X	X*						
35.25	50	10868	8.62	5.69	4.31	2.85			X	X*						
41.29	42	10496	6.99	4.62	3.50	2.31			X	X*						
50.98	34	9717	5.24	3.46	2.62	1.73			X	X*						
60.66	29	8885	4.09	2.70	2.04	1.35	X	X	X*							
74.87	23	9558	3.49	2.30	1.74	1.15	X	X	X*							
85.10	21	7045	2.35	1.55	1.17	0.77	X	X								
105.08	17	7629	2.06	1.36	1.03	0.68	X	X								

* Caution - The motor power may exceed the gear unit's mechanical torque capacity
 ◇ The mechanical power limit of the solid input shaft type "W" may limit the reducer rating.
 All ratings are mechanical. See page 14 for thermal considerations.

lb	W	56C	140TC	180TC	210TC	250TC
SK 41E	101	90	106	106	137	159
SK 42	143	132	148	148	179	201

PARTS LIST

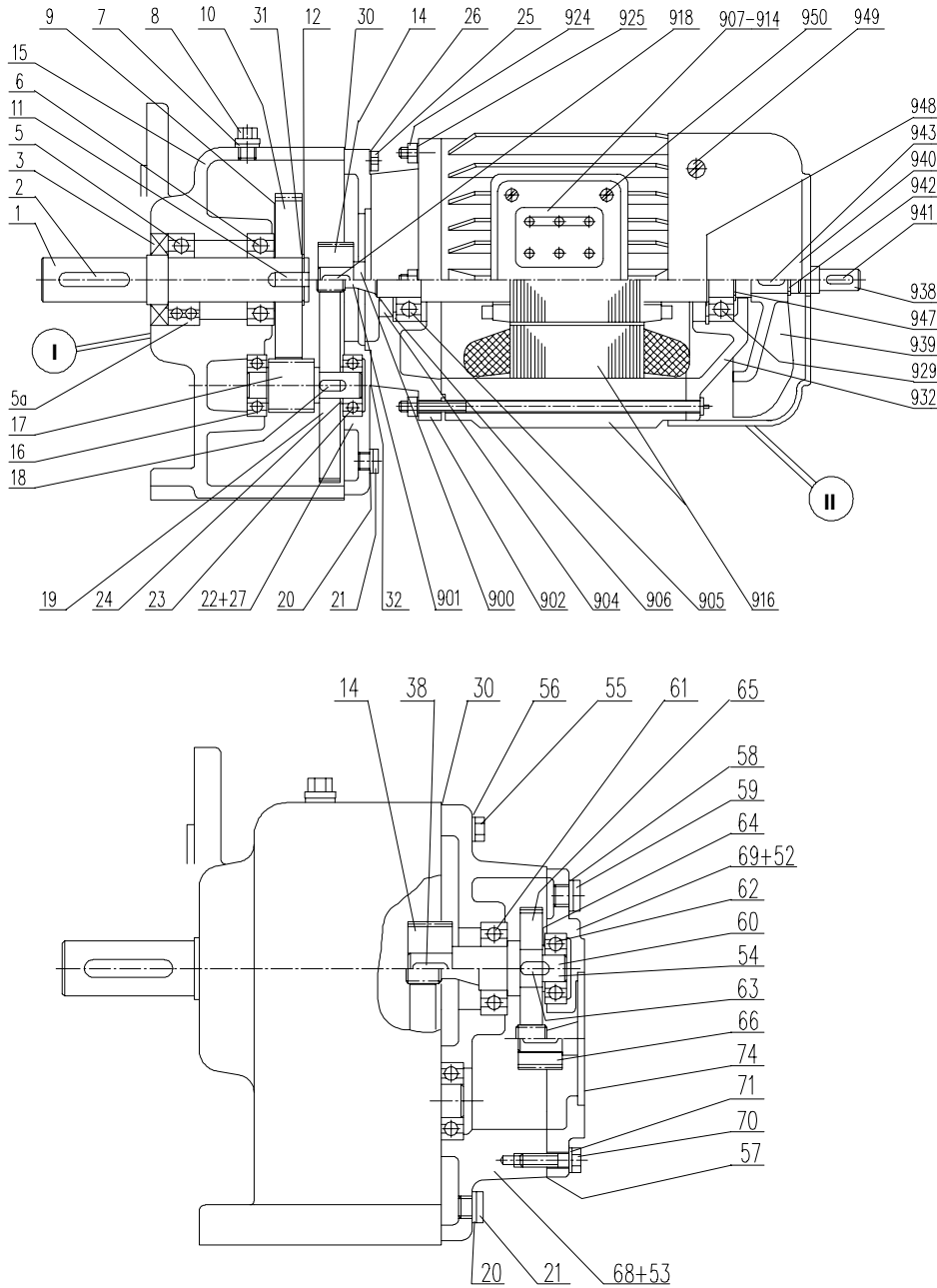

- 1 Output shaft
- 2 Key
- 3 Shaft seal
- 5 Output shaft bearing, normal
- 5a Output shaft bearing, reinforced
- 6 Output shaft bearing
- 7 Seal
- 8 Vent screw
- 9 Shim
- 10 Driven gear
- 11 Key
- 12 Circlip
- 14 Driving pinion
- 15 Gear case
- 16 Pinion shaft bearing
- 17 Driven pinion
- 18 Key
- 19 Driving gear
- 20 Seal
- 21 Plug
- 22 Gear case cover
- 23 Pinion shaft bearing
- 24 Shim
- 25 Hexagon bolt
- 26 Washer
- 27 Spiral pin
- 30 Seal
- 31 Shim
- 32 Seal
- 52 Spiral pin
- 53 Spiral pin
- 54 Intermediate shaft, gearcut
- 55 Hexagon bolt
- 56 Washer
- 57 Seal
- 58 Seal
- 59 Plug
- 60 Intermediate shaft, plain
- 61 Grooved ball bearing
- 62 Grooved ball bearing
- 63 Key
- 64 Shim
- 65 Driving gear
- 66 Driving pinion
- 68 Gear case 3rd.-red.
- 69 Gear case cover
- 70 Hexagon bolt
- 71 Washer
- 74 Seal
- 900 Rotor with shaft, plain
- 901 Rotor with shaft, gearcut
- 902 End shield A
- 904 Shaft seal
- 905 Bearing A
- 906 Bearing shim
- 907 Terminal box frame
- 908 Terminal box cover
- 909 Terminal box frame gasket
- 910 Terminal box cover gasket
- 911 Terminal board
- 914 cable entry gland
- 916 Stator case
- 918 Key
- 924 Collar bolt
- 925 Hexagonal nut
- 929 Bearing B
- 932 End shield B
- 938 Second motor shaft end
- 939 Fan
- 940 Fan cover
- 941 Key
- 942 Circlip
- 943 Key
- 947 Circlip
- 948 Circlip
- 949 Oval flat-head bolt
- 950 Oval flat-head bolt

RECOMMENDED SPARE PARTS

Bearings – all Gaskets – all Shims – all
 Seals – all Seal Plugs – all

IMPORTANT!

When ordering parts, it is necessary to have the *NORD SERIAL NUMBER* from the unit the parts are for. The serial number will dictate the correct parts for that particular unit. The gearbox nameplate will have the serial number on it.

Lubrication



Lubrication Types

Proper gearbox lubrication is essential in order to reduce friction, heat, and component wear. Lubricants reduce heat and wear by inserting a protective “fluid boundary” between mating parts and preventing direct metal to metal contact. Lubricants also help prevent corrosion and oxidation, minimize foam, improve heat transfer, optimize reducer efficiency, absorb shock loads and reduce noise.

Mounting position not only determines the proper fill-level but may also have some effect on final reducer assembly. If considering any mounting positions that are not shown as catalog-standard options, it is critical that the customer consult with NORD prior to ordering. Unless otherwise specified, NORD supplies most all gear units (*) factory-filled with the standard lubrication type and the appropriate amount of lubricating oil.

* Gear units SK10282, SK10382, SK11282, SK11382, SK12382, and SK9096.1 are supplied without oil.

Standard Oil Lubricants

Gear Unit Type	Ambient Temperature	Oil Type	ISO Viscosity	Manufacturer Brand / Type
Helical-Inline, Parallel-Shaft, & Helical-Bevel	-4 to 104 °F (-20 to 40 °C)	MIN-EP	VG 220	Shell / Omala 220 ♣
	-40 to 140 °F (-40 to 60 °C)	PAO	VG 220	Mobil SHC 630 ♣
	23 to 104 °F (-5 to 40 °C)	FG	VG 220	Shell / FM 220 ♣
Helical-Worm	-22 to 122 °F (-30 to 50 °C)	PAO	VG 680	Mobil SHC 636 ♣

Optional Oil Lubricants

Gear Unit Type	Ambient Temperature	Oil Type	ISO Viscosity	Manufacturer Brand / Type
Helical-Inline, Parallel-Shaft, & Helical-Bevel	-31 to 176 °F (-35 to 80 °C)	PAO	VG 460	Mobil SHC 634
	-40 to 77 °F (-40 to 25 °C)	PAO	VG 150	Mobil SHC 629
	-40 to 140 °F (-40 to 60 °C)	FG-PAO	VG 220	Shell / Cassida GL 220
Helical-Worm	-40 to 122 °F (-40 to 50 °C)	FG-PAO	VG 460	Shell / Cassida GL 460

Standard Bearing Grease Lubricants

Grease Type / Thickener	Ambient Temperature	NLGI Grade	Manufacturer Brand / Type
Standard (Li-Complex)	-22 to 140 °F (-30 to 60 °C)	NLGI 2	Shell Albida EP LC2 ♣
High Temp (Polyurea)	-13 to 176 °F (-25 to 80 °C)	NLGI 2	Mobil Polyrex EP 2 ♣
Food-Grade (Al-Complex)	-13 to 104 °F (-25 to 40 °C)	NLGI 2	Mobil Grease FM 222 ♣

♣ Stocked Lubricant

Oil Formulation Codes

MIN-EP	Mineral Oil with EP Additive
PAO	Synthetic Polyalphaolefin Oil
PG	Synthetic Polyglycol Oil
FG	Food-Grade Oil
FG-PAO	Food-Grade, Synthetic Polyalphaolefin Oil

Important Notes

- In worm gears avoid using (EP) gear oils that contain sulfur-phosphorous chemistries, as these additives can react adversely with bronze worm gears and accelerate wear.
- Food grade lubricants must be in compliance with FDA 212 CFR 178.3570 and qualify as a NSF-H1 lubricant. Please consult with lubrication manufacture for more information.
- When making a lubrication change, check with the lubrication supplier to assure compatibility and to obtain recommended cleaning or flushing procedures.
- Do not mix different oils with different additive packages or different base oil formulation types. Polyglycol (PG) oils are not miscible with other oil types and should never be mixed with mineral oil, or Polyalphaolefin (PAO) oil.
- Please Consult NORD if considering cold-temperature oils below an ISO Viscosity VG100 or lower.

In-line Foot Mount Positions & Oil Fill Quantities

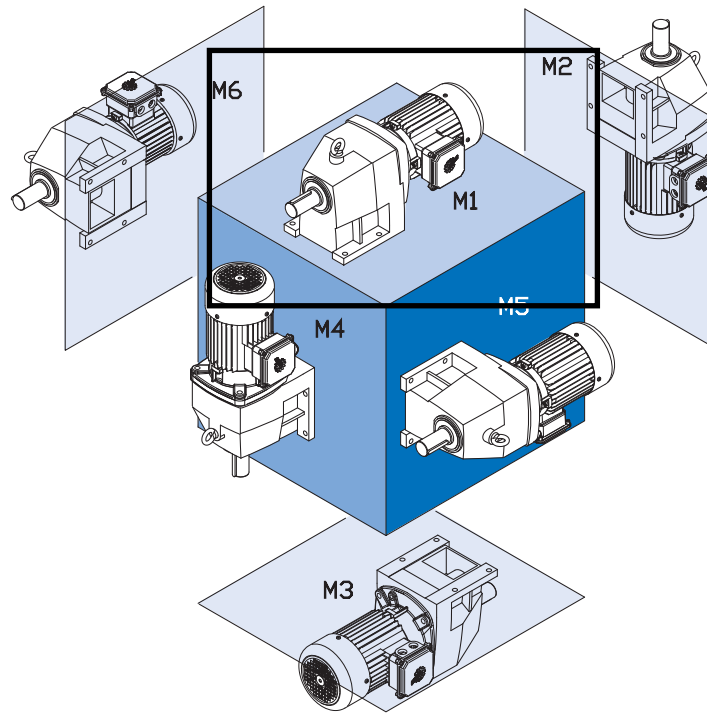

Mounting Position	M1		M2		M3		M4		M5		M6	
	Quarts	Liters	Quarts	Liters	Quarts	Liters	Quarts	Liters	Quarts	Liters	Quarts	Liters
SK02	0.16	0.15	0.63	0.60	0.74	0.70	0.63	0.60	0.42	0.40	0.42	0.40
SK03	0.32	0.30	1.06	1.00	0.85	0.80	0.95	0.90	0.63	0.60	0.63	0.60
SK11E	0.26	0.25	0.53	0.50	0.58	0.55	0.42	0.40	0.37	0.35	0.37	0.35
SK12	0.26	0.25	0.79	0.75	0.90	0.85	0.79	0.75	0.53	0.50	0.53	0.50
SK13	0.63	0.60	1.32	1.25	1.16	1.10	1.27	1.20	0.74	0.70	0.74	0.70
SK21E	0.63	0.60	1.27	1.20	1.27	1.20	1.06	1.00	1.06	1.00	1.06	1.00
SK22	0.53	0.50	1.90	1.80	2.11	2.00	1.90	1.80	1.43	1.35	1.43	1.35
SK23	1.37	1.30	2.54	2.40	2.43	2.30	2.48	2.35	1.69	1.60	1.69	1.60
SK31E	1.16	1.10	2.85	2.70	2.33	2.20	2.43	2.30	1.80	1.70	1.80	1.70
SK32	0.95	0.90	2.64	2.50	3.17	3.00	3.07	2.90	2.11	2.00	2.11	2.00
SK33N	1.69	1.60	3.07	2.90	3.38	3.20	3.91	3.70	2.43	2.30	2.43	2.30
SK41E	1.80	1.70	2.75	2.60	3.49	3.30	2.64	2.50	2.75	2.60	2.75	2.60
SK42	1.37	1.30	4.76	4.50	4.76	4.50	4.55	4.30	3.38	3.20	3.38	3.20
SK43	3.17	3.00	5.92	5.60	5.50	5.20	6.98	6.60	3.81	3.60	3.81	3.60
SK51E	2.33	2.20	4.65	4.40	4.97	4.70	4.23	4.00	3.59	3.40	3.59	3.40
SK52	2.64	2.50	7.40	7.00	7.19	6.80	7.19	6.80	5.39	5.10	5.39	5.10
SK53	4.76	4.50	9.20	8.70	8.14	7.70	9.20	8.70	6.34	6.00	6.34	6.00
SK62	6.87	6.50	15.9	15.0	13.7	13.0	16.9	16.0	15.9	15.0	15.9	15.0
SK63	13.7	13.0	15.3	14.5	15.3	14.5	16.9	16.0	13.7	13.0	13.7	13.0
SK72	10.6	10.0	24.3	23.0	19.0	18.0	27.5	26.0	24.3	23.0	24.3	23.0
SK73	21.7	20.5	21.1	20.0	23.8	22.5	28.5	27.0	21.1	20.0	21.1	20.0
SK82	14.8	14.0	37.0	35.0	28.5	27.0	46.5	44.0	33.8	32.0	33.8	32.0
SK83	31.7	30.0	32.8	31.0	35.9	34.0	39.1	37.0	34.9	33.0	34.9	33.0
SK92	26.4	25.0	77.1	73.0	49.7	47.0	80.3	76.0	55.0	52.0	55.0	52.0
SK93	56.0	53.0	74.0	70.0	62.4	59.0	76.1	72.0	51.8	49.0	51.8	49.0
SK102	38.1	36.0	83.5	79.0	69.8	66.0	107.8	102	75.1	71.0	75.1	71.0
SK103	78.2	74.0	75.1	71.0	78.2	74.0	102.5	97.0	70.8	67.0	70.8	67.0

Oil Plugs

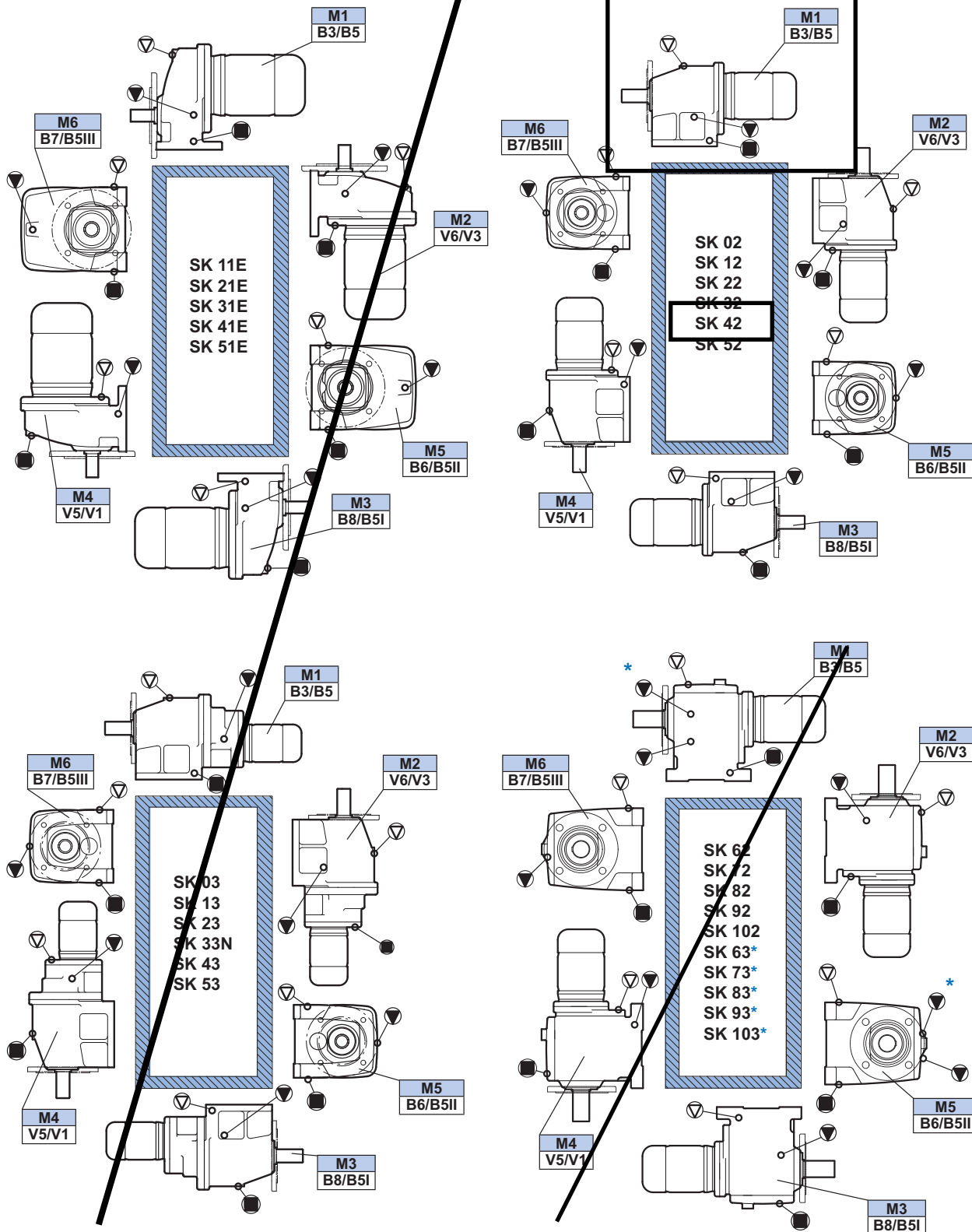
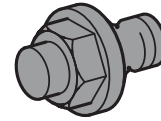

SERVICE

▽ = Vent ▼ = Oil Level ■ = Oil Drain



Helical In-line Weights - Reducer



Approximate Weights [lb]

Type	W	56C	140TC	180TC	210TC	250TC	280TC	320TC	360TC
SK 02	26	44	44	–	–	–	–	–	–
SK 03	35	–	–	–	–	–	–	–	–
SK 11	35	35	49	–	–	–	–	–	–
SK 12	48	48	57	–	–	–	–	–	–
SK 13	46	–	–	–	–	–	–	–	–
SK 12/02	49	49	–	–	–	–	–	–	–
SK 21	49	46	46	59	–	–	–	–	–
SK 22	64	73	73	77	–	–	–	–	–
SK 23	68	86	86	–	–	–	–	–	–
SK 22/02	77	93	93	–	–	–	–	–	–
SK 31	59	62	62	66	–	–	–	–	–
SK 32	88	90	90	95	–	–	–	–	–
SK 33 N	95	103	103	–	–	–	–	–	–
SK 32/12	106	115	115	132	–	–	–	–	–
SK 41	101	91	88	92	130	159	–	–	–
SK 42	143	138	132	143	174	201	–	–	–
SK 43	154	152	152	156	–	–	–	–	–
SK 42/12	143	148	148	170	–	–	–	–	–
SK 51	121	105	105	117	147	150	199	–	–
SK 52	207	169	169	174	205	207	285	–	–
SK 53	227	185	185	189	–	–	–	–	–
SK 52/12	207	179	179	234	–	–	–	–	–
SK 62	377	–	–	317	354	392	392	567	567
SK 63	328	295	288	299	330	332	405	–	–
SK 63/22	348	329	329	333	–	–	–	–	–
SK 63/23	353	335	335	–	–	–	–	–	–
SK 72	529	–	–	440	477	515	515	721	721
SK 73	551	–	–	416	453	491	491	743	743
SK 73/22	527	452	452	456	–	–	–	–	–
SK 73/32	551	553	553	558	571	–	–	–	–
SK 82	880	–	–	666	702	741	741	962	962
SK 83	787	–	–	631	669	706	706	979	979
SK 83/32	787	723	723	728	741	–	–	–	–
SK 83/42	842	837	837	848	879	906	–	–	–
SK 92	1268	–	–	–	–	1215	1215	1350	1350
SK 93	1182	–	–	1184	1184	1239	1239	1374	1374
SK 93/42	1237	1226	1226	1272	1272	1294	–	–	–
SK 93/52	1301	–	–	1276	1306	1308	1308	–	–
SK 102	1821	–	–	–	–	–	1702	1837	1837
SK 103	1775	–	–	1667	1667	1722	1722	1857	1857
SK 103/52	1784	1773	1773	1819	1819	1840	1860	–	–

Above weights are approximate. Depending upon ratio, oil quantity and optional equipment, reducer weights may be different than shown. Exact weights can be obtained after the unit is fully assembled.



No.:

Date: 30-MAY-2012

Customer :

TECHNICAL PROPOSAL
Three-phase induction motor - Squirrel cage rotor

Product line : W22 NEMA Premium - Ball Bearings

Catalog Number : 01518ET3E254TC-W22

List Price :

Notes:

Performed by:

Checked:



No.:

Date: 30-MAY-2012

DATA SHEET

Three-phase induction motor - Squirrel cage rotor

Customer :
Product line : W22 NEMA Premium - Ball Bearings

Frame : 254T
Output : 15 HP
Frequency : 60 Hz
Poles : 4
Full load speed : 1765
Slip : 1.94 %
Voltage : 208-230/460 V
Rated current : 39.8-36.0/18.0 A
Locked rotor current : 234/117 A
Locked rotor current (I_L/I_n) : 6.5
No-load current : 16.0/8.00 A
Full load torque : 44.0 lb.ft
Locked rotor torque : 230 %
Breakdown torque : 270 %
Design : B
Insulation class : F
Temperature rise : 80 K
Locked rotor time : 17 s (hot)
Service factor : 1.25
Duty cycle : S1
Ambient temperature : -20°C - +40°C
Altitude : 1000
Degree of Protection : IP55
Approximate weight : 251 lb
Moment of inertia : 2.6198 sq.ft.lb
Noise level : 64 dB(A)

	D.E.	N.D.E.	Load	Power factor	Efficiency (%)
Bearings	6309 C3	6209 C3	100%	0.83	92.4
Regreasing interval	20000 h	20000 h	75%	0.78	91.7
Grease amount	13 g	9 g	50%	0.68	91.0

Notes:

Performed by

Checked



No.:

Date: 30-MAY-2012

PERFORMANCE CURVES RELATED TO RATED OUTPUT

Three-phase induction motor - Squirrel cage rotor

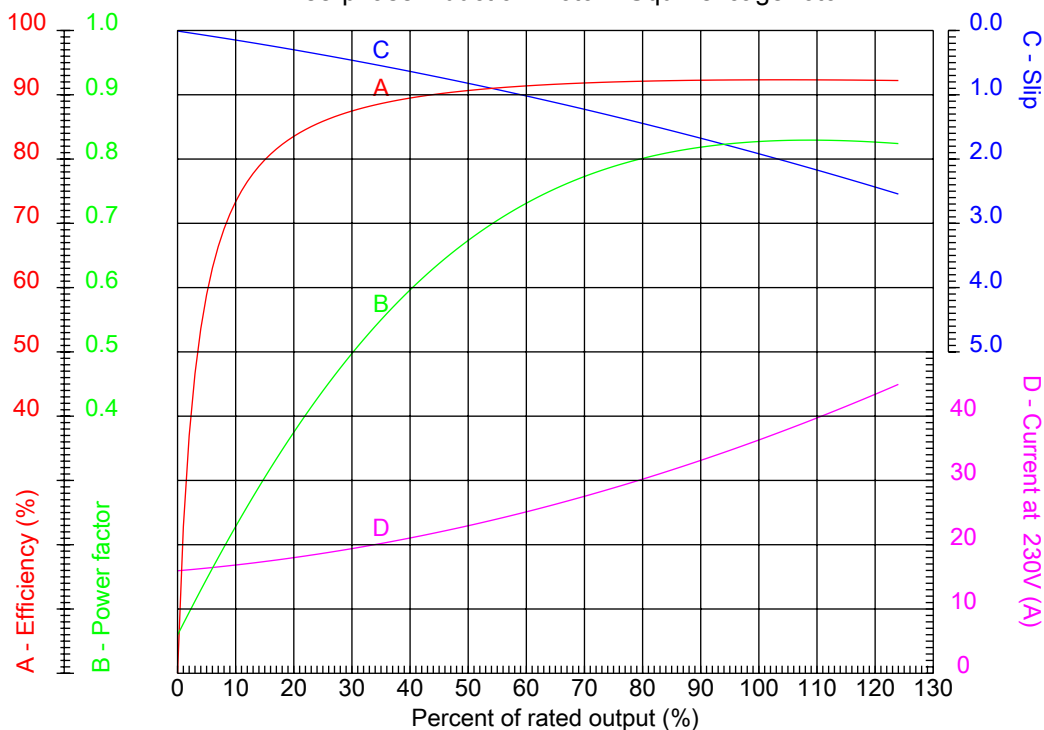

Customer :
 Product line : W22 NEMA Premium - Ball Bearings

Frame	: 254T	Locked rotor current (I _l /I _n)	: 6.5
Output	: 15 HP	Duty cycle	: S1
Frequency	: 60 Hz	Service factor	: 1.25
Full load speed	: 1765	Design	: B
Voltage	: 208-230/460 V	Locked rotor torque	: 230 %
Rated current	: 39.8-36.0/18.0 A	Breakdown torque	: 270 %
Insulation class	: F		

Notes:

Performed by

Checked



No.:

Date: 30-MAY-2012

CHARACTERISTIC CURVES RELATED TO SPEED

Three-phase induction motor - Squirrel cage rotor

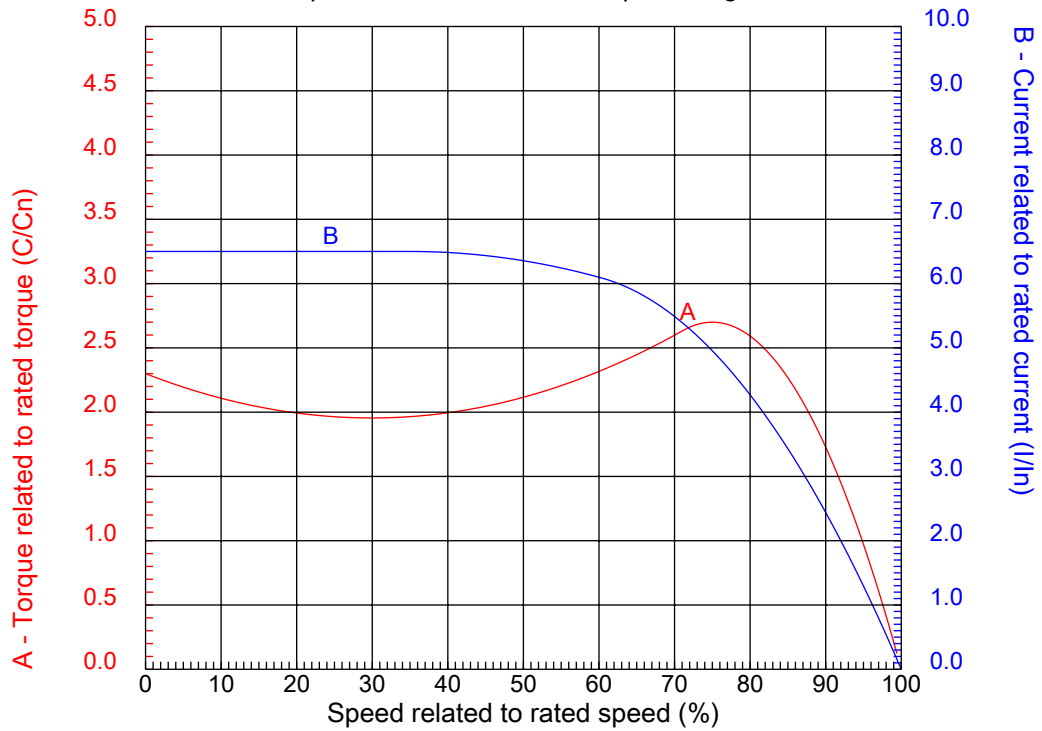

Customer :
 Product line : W22 NEMA Premium - Ball Bearings

Frame	: 254T	Locked rotor current (I _l /I _n)	: 6.5
Output	: 15 HP	Duty cycle	: S1
Frequency	: 60 Hz	Service factor	: 1.25
Full load speed	: 1765	Design	: B
Voltage	: 208-230/460 V	Locked rotor torque	: 230 %
Rated current	: 39.8-36.0/18.0 A	Breakdown torque	: 270 %
Insulation class	: F		

Notes:

Performed by

Checked

1 2 3 4 5 6 7 8

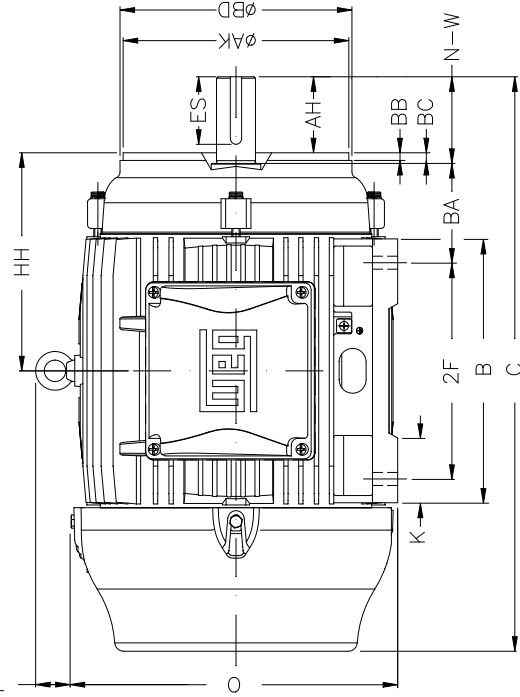
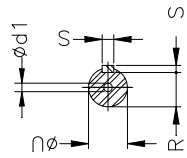
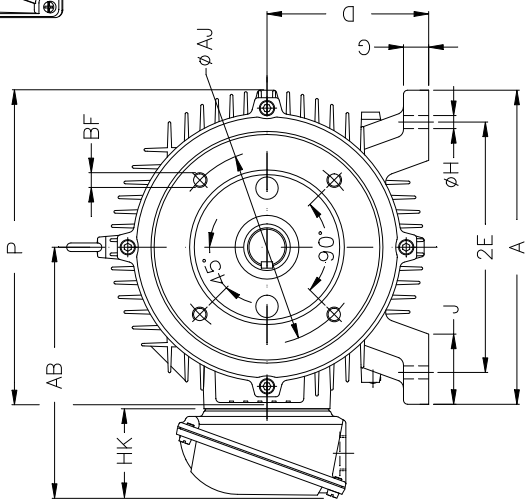
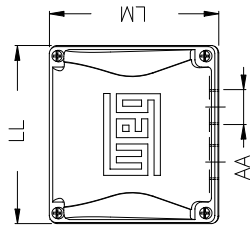

Notes:											
Performed by:											
Checked:											
Customer:											
W22 NEMA Premium - Ball Bearings											
Three-phase induction motor											
Frame 254T - IP55											
30-MAY-2012											
2E	10.000	J	2.539	A	12.126	P	12.953	AB	10.394		
2F	8.252	K	2.559	B	10.000	BA	4.250	U	1.625		
N-W	4.000	ES	2.756	S	0.375	R	1.406	depth	0.375		
D	6.250	G	0.827	HB	3.061	O	12.598	T	2.087		
HF	6.565	HH	8.376	HK	3.937	H	0.531	C	23.213		
LL	7.795	LM	7.402	AA	NPT 1 1/2"	d1	A4	d2	A4		
Flange FC-184		AJ	7.250	AK	8.500	BD	8.875	BF	UNC 1/2"x13		
BB	0.250	BC	0.250	AH	3.750						



greater than 95%, regardless of the operating schedule. It should be highlighted that in this situation it is strongly recommended that an epoxy paint known as internal anti-corrosive painting is applied in the internal components of the motor.

More information can be obtained in section 7.3.

For all frame sizes, W22 motors can be provided with space heaters suitable for 110-127 V, 220-240 V and 380-480 V. Motors in frame sizes 586/7T and 588/9T are supplied with space heaters for 220-240 V as standard. As an option, dual voltage heaters of 110-127 / 220-240 V can be supplied for frame sizes 182T to 588/9T.

The power rating and number of space heaters fitted depends on the size of the motor as indicated in table 11 below:

Frame	Quantities	Total power rated (W)
143 to 145	1	11
182 to 184	2	22
213 to 256	2	30
284 to 326	2	38
364/5 to 404/5	2	56
444/5 to 504/5	2	140
586/7 to 588/9	2	174

Table 11 – Power and quantity of space heaters

10. Motor protections

Protections available for W22 can be classified as follows:

- Based on operating temperature
- Based on operating current.

In section 12 - Construction features it is possible to identify the type of protection for each W22 line.

10.1 Protection based on operating temperature

Continuous duty motors must be protected from overload either by a device integrated into the motor winding or via an independent protection system, usually a thermal relay with rated or setting current, equal to or below the value obtained when multiplying the power supply rated current (I_n), as per table 12.

Service Factor	Relay setting current
1.0 up to 1.15	I _n x S.F.
≥ 1.15	(I _n x S.F.) – 5%

Table 12 – Relay setting current referred to service factor

RTD

These are temperature detectors (figure 26) with operating principle based on the properties that some materials vary the electric resistance with the variation in temperature (usually platinum, nickel or copper).



Figure 26 - RTD

They are also fitted with calibrated resistances that vary linearly with temperature, allowing continuous reading of motor operating temperature through a monitoring display, with high precision rate and response sensitivity. The same detector can serve as alarm (with operation above the regular operating temperature) and trip (usually set up for the maximum temperature of the insulation class).

Thermistor (PTC)

These are thermal protectors consisting of semiconductor detectors with sudden variation of the resistance when reaching a certain temperature (figure 27).



Figure 27 – Thermistor (PTC)

PTC is considered a thermistor with the resistance increasing drastically to a well defined temperature figure. This sudden resistance variation blocks the PTC current, causing the output relay to operate, and the main circuit to switch-off. The thermistors are of small dimensions, do not wear and have quicker response if compared to other protectors, although they do not allow continuous monitoring of motor operating temperature.

Together with their electronic circuits, these thermistors provide full protection against overheating caused by overload, under or overvoltage or frequent reversing operations.

Where thermistor protection is required to provide both alarm and trip operation, it is necessary for each phase of the motor winding to be equipped with two sets of appropriately rated thermistors.

WEG Automation has a product called RPW which is an electronic relay intended specifically to read the PTC signal and operate its output relay. For more information go to the website www.weg.net.

Thermostats

These are silver-contact thermal sensors, normally closed, that operate at certain temperature rise. When their operating temperature decreases, they go back to the original position instantaneously, allowing the silver contact to close again. The thermostats are series-connected with the contactor coil, and can be used either as alarm or trip.

There are also other types of thermal protectors such as PT-1000, KTY and thermocouples. Contact your local WEG office closest to you for more information.

10.2 Protection based on operating current

Overloads are processes that usually make the temperature increase gradually. To solve this problem, the thermal protectors described in item 10.1 are quite suitable. However, the only way to protect motors against short-circuit currents is the application of fuses. This type of protection depends directly on the current and it is highly effective in cases of locked rotor.

WEG Automation supplies fuses in versions D and NH. Go to the site www.weg.net for more information.

Typical Thermostat Control Schematic

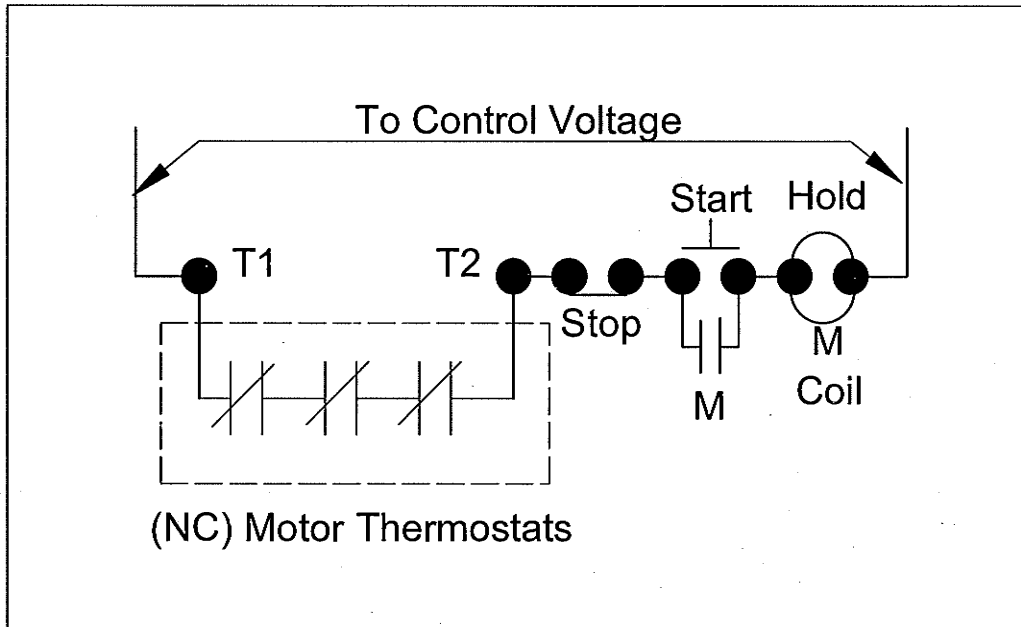



INSTALATION OF SPACE HEATERS IN INDUCTION MOTORS

NORM

WED-002

Page 1 of 2

Source: WEG / TOP - 0137

Rev. 00

06/01/2004

Company: WEM

Origin:

1. OBJECTIVE:

This standard aims at providing specification and installation procedures for “space-heater” installed in WEG motors.

2. WATTAGE AND CONNECTIONS:

FRAMES		TOTAL WATTS (W ± 10%) ³⁾	SPACE HEATER VOLTAGE					
NEMA	IEC		110 ± 22V		220 ± 44V		440 ± 88V	
			TYPE	CONNECTION/Req.	TYPE	CONNECTION/Req.	TYPE	CONNECTION/Req.
	63	8 ¹⁾	20W/m-110V		20W/m-220V		20W/m-440V	
	71							
	80							
143 145	90			Req. = 1,512 Ω		Req. = 6,050Ω		Req.=12,100Ω
100		16 ²⁾	20W/m-110V		20W/m-220V		20W/m-440V	
182 184	112							
				Req. = 756Ω		Req. = 3,025Ω		Req. = 6,050Ω
213 215	132	24	30W/m-110V		30W/m-220V		30W/m-440V	
				Req.= 504Ω		Req. = 2,017Ω		Req. = 8,067Ω
254 256	160	48	30W/m-110V		30W/m-220V		30W/m-440V	
284 286	180							
324 326	200							
				Req. = 252Ω		Req. = 1,008.5Ω		Req = 40,033.5 Ω
364 365	225	79	35W/m-110V		35W/m-220V		35W/m-440V	
404 405	250							
				Req.= 153Ω		Req. = 612Ω		Req.=2,450Ω
444 445	280	158	35W/m-110V		35W/m-220V		35W/m-440V	
447 449								
504/5	315							
5008	315B							
586/7	355							
				Req. = 76.5Ω		Req. = 306Ω		Req. = 1,225Ω

Edited by: Valone Gomes



Note: 1) For voltage of 440V, the total power is = 16W.

2) For voltage of 440V, the total power is = 32W.

3) The total Space Heater Watts is calculated according to: $P = \frac{V^2}{R_{eq}} (W)$

3. SPACE HEATER INSTALLATION

3.1. Space Heater is installed on the stator-winding head (at the opposite side of the leads) before the stator is pressed into the frame. On frame 364 and above, the space heater is installed into the stator-winding head (same side of the leads) after the winding head has been pressed.

3.2. Space Heater is fasten at, minimum, 4 points by nylon cord. For frames 364 and above it is fastened with a polyester jacket.

Notes:

- 1) Space heater installation does not require varnish impregnation.
- 2) Space heater leads are identified by:
 - R1 for the first space heater and
 - R2 for the second space heater (when installed).

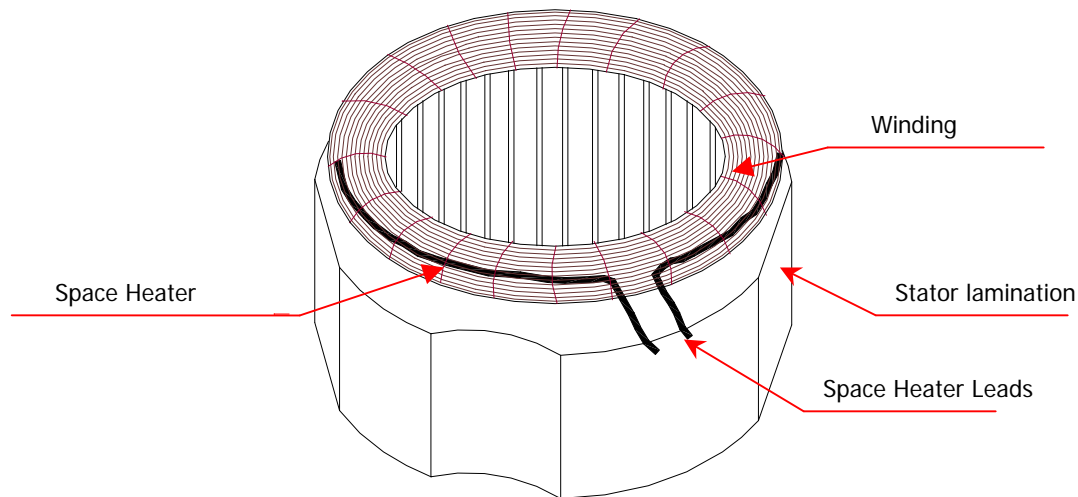

Tab 5

Pump Technical Data: BN 57/8N

seepex date	5/24/2012	commission no.	832029-832030		
customer	Weaver Construction Management - Englewood, CO				
seepex job no.	2113909	offer/item	5383/0134 item 1		
project	PO# 9103				
2 of	seepex progressive cavity pump type BN 35-6L/A1-C1-C6-R0-4E-X X=0320, 06B1, 0804, 11R0, 163, 17T,				
conveying product denomination	Scum				U/495/SC
rate of solids	0.01-0.3%	viscosity	ass. <500 cPs		
size of solids	no advice	pH-value	ass. 5-9		
specific gravity	ass. 1.05	temperature	0.5-23 C		
composition	no advice				
remarks					
performance data	nom.	min	max		
conveying capacity		47	94		USGPM
pump speed		104	209		rpm
press in press. branch		6.7	6.7		psi
press in suct. branch	assume flooded				
differential pressure	6.7	psi	operating torque	63	lb.ft
required drive power	3.16	Hp	starting torque	185	lb.ft
remarks	Data according to performance curve				
technical pump data					
range	BN	kind of install.	horizontal		
size	35	direction of rot.	counterclockwise		
pressure stage	6L	pos. of branch	2		
component	material	design/option			
lantern	GG25 grey cast iron	standard			
suction casing	GG25 grey cast iron	suction casing with cleanouts both sides and drain plug			
suction connection		DN 5" ANSI B16.5 150lb.			
pressure branch	GG25 grey cast iron	DN 4" ANSI B16.5 150lb.			
pressure connection		standard			
joint	standard	standard			
joint grease	30321	standard			
joint seal	EPDM	standard			
coupling rod	1.4021/AISI 420	standard			
rotor	1.2436/AISI D6	standard with ductile coating			
stator	EPDM	TSE design w/ 316Ti SS sensor sleeve			
seal casing	1.4571/AISI 316 Ti	Single Acting Cartridge Seal			
seal		Burgman Cartex QN5-070-Q1Q1-EMG			
plug-in shaft	1.4021/AISI 420	drilled Φ40 x 75			
special designs	TSE pump end components including controller				

general operating data

kind of operation continuous operation 8hr day
site of installation suitable for indoor installation
remarks

drive

type GearBox
make Nord **ratio** i=8.5
model SK42ALF-180TC- NSD **nom/ min - max**
mounting position M1(B5) **output speed** 206/ 104- 209 **rpm**
flange dia 250 mm **motor speed** 1755/ 891- 1779 **rpm**
output shaft 716/0170-002B4 **frequency** 60/ 30- 61 **Hz**
special AL bearings, NSD – Nord Severe Duty

electric motor

manufacturer WEG
model 00518ET3E184TC-W22 **voltage** 3x208-230/460 VAC
nominal power 5 Hp **rated frequency** 60 Hz
mounting position F1 (C-face, footed) **enclosure** TEFC
starting direct on VFD **thermal class** F
special Severe Duty, 184TC, 20:1 CT
E80- Thermostats(N.C.), E30- Space Heaters

dry running protection device

model TSE – 115 VAC **voltage** 110-115 VAC / 50/60 Hz.
delivery scope
remarks TSE with NPT connections in IP55 connection head

baseplate

standard B-ST-LS US design **material** steel
drawing no. [801-200/0170-C-155A3](#) **surface** painted
special/accessories grout holes, drain pan w/drain connection and 3/4" NPT drain plug
baseplate extended for motor support

paint

execution standard- epoxy
color RAL 5013 (blue)
remarks surface prep carbon steel only to SSPC SP6
surface prep all to SSPC SP1
primer - Tnemec series 37H-77 - 2 - 3.5 mil dft
finish - Tnemec Series N69 Hi-Build Epoxoline II, 2 coats each 1.5 – 2.5 mil dft
stainless steel components are not to be painted

packing

packing type skid
marking 2113909

documentation

dimensional drawing no. [122989](#) **operating manual** 1 copy English
sectional drawing no. [062-004_1](#)
shaft sealing sect. view [262-0GB/0170-0-112_3](#)
remarks

additional accessories / special designs / remarks

overpressure devices

manufacturer	Onyx	series	PSW
center material	CS	center flange size	4" ANSI B16.5 150lbs RF
end plate material	derlin acetal	sleeve material	Buna
gauge			
manufacturer	Ashcroft	series	1008
diameter	4"	range	0-100 psi
pressure switch			
manufacturer	Ashcroft	model	B4 24 B
switch type	SPDT	range	0-100 psi
enclosure	NEMA 4X	set pressure	50 psi
remarks			

Proco Flex Connection – Discharge Side (Qty 1)

FA-231
 150" ANS Drilling
 350 psi max rated @150°F max
 Single Filled Arch csnitrile mtl
 4" x 6" Expansion Joint
 w/ 100# drilled ring set & back-up flange rings

Spare Parts:

Rotor
 Stator
 Joint Assembly Kit
 Mechanical Seal

Anchor Bolts: HAS – R 316SS (qty 4 per pump)

QA Testing:

Certificate of Compliance
 Per DIN EN 10204 Type 2.1

Tag: SCP-1 and SCP-2

Characteristic Curves
Size
35-6L

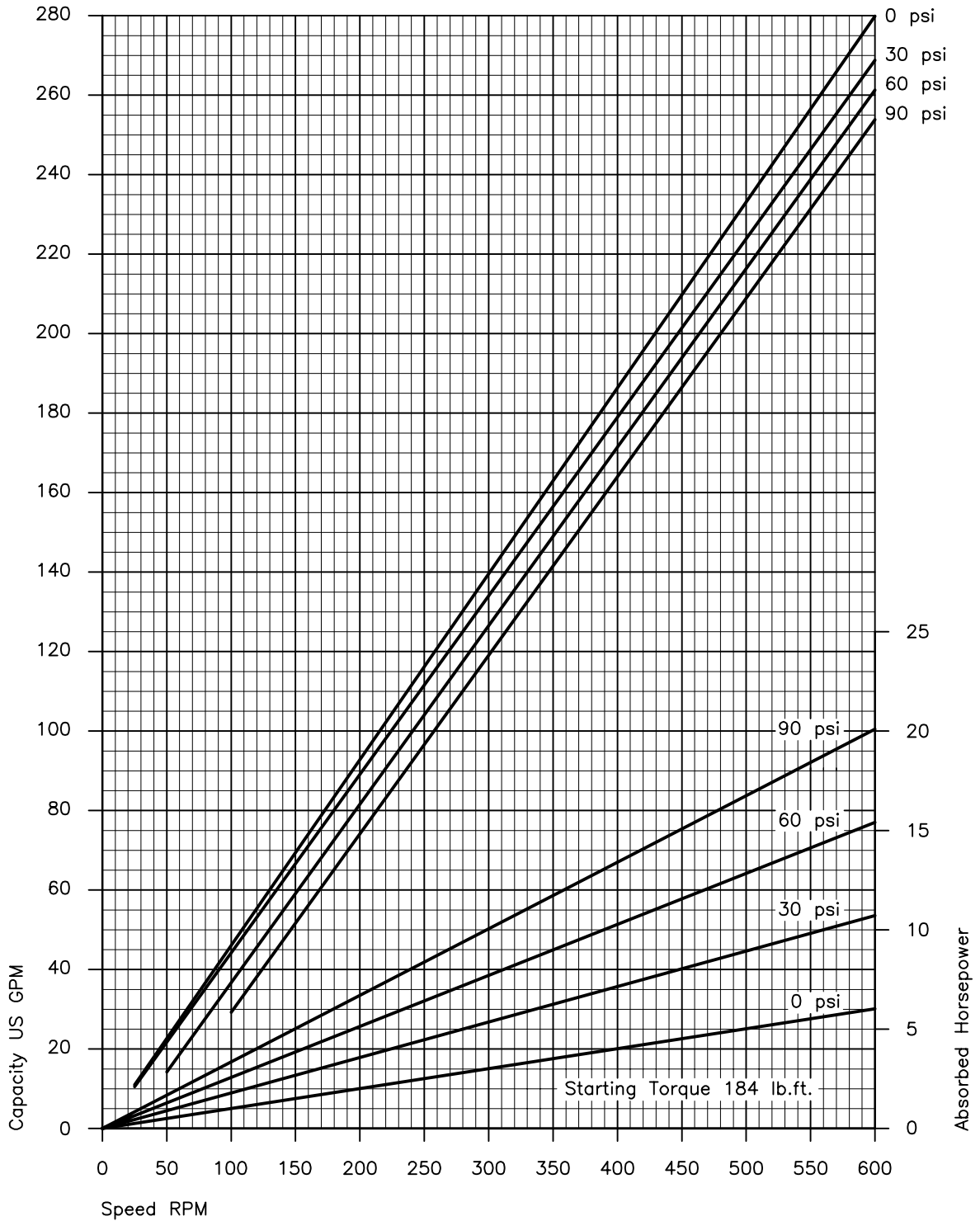

Values based upon water 68°F ; For notes on drive selection refer to PER

CHA.35-6L B 12.02us

type	constant c
0005-24	3,1076
0015-24	1,7972
003-12	1,4381
003-24	1,4229
006-12	0,9558
006-24	0,9558
01-48	0,5743
012-12	0,6144
012-24	0,6144
025-6L	0,4828
025-12T	0,6271
05-6LT	0,6837
025-12	0,3792
025-24	0,3768
05-12	0,2379
05-24	0,2306
1-6L	0,2379
1-12	0,1547
1-12V	0,1547
1-24	0,1541
1-24V	0,1541
2-6L	0,1547
2-12	0,0971
2-12V	0,0971
2-24	0,0974
2-24V	0,0974
5-6L	0,0965
5-6LS	0,0885
5-12	0,0599
5-12V	0,0599
5-24	0,0603
5-24V	0,0603
5-48	0,0603
8-12T	0,091
10-6L	0,0597
10-6LS	0,0527
10-12	0,0379
10-12V	0,0379
10-24	0,0380
10-24V	0,0380
10-48	0,0380
14-12	0,0307
15-6LT	0,1055
15-12T	0,0675
17-6L	0,0379
17-6LS	0,0362
17-12	0,0256
17-12V	0,0256
17-24	0,0257
17-24V	0,0257
17-48	0,0257
26-6L	0,0307
26-12	0,0192
30-6LT	0,0644
30-12T	0,0452
35-6L	0,0253
35-6LS	0,0247
35-12	0,0155
35-12V	0,0155
35-18	0,0156
35-24	0,0156
35-24V	0,0156
35-48	0,0156
40-6LT	0,0524

type	constant c
52-6L	0,0194
52-6LS	0,0177
52-12	0,0127
55-6LT	0,0432
55-12T	0,0278
55-24	0,0157
70-6L	0,0154
70-6LS	0,0156
70-12	0,0100
70-12V	0,0100
70-18	0,0100
70-24	0,0100
70-48	0,0100
75-6LT	0,0344
100-6L	0,0126
100-6LS	
100-18	0,0100
110-6LT	0,0277
110-12T	0,0179
130-6L	0,0099
130-6LS	0,0099
130-12	0,0066
130-12V	0,0066
130-18	0,0067
200-6L / 202-6L	0,0079
200-12T	0,0109
240-12	0,0045
300-6L	0,0057
300-12T	0,0082

BIG sizes

type	constant c
240-6C	0,0045
240-9C	0,0045
240-12C	0,0045
240-12L	0,0045
240-18L	0,0045
240-24C	0,0044
240-24D	0,0045
300-3TR	0,0082
300-9TR	0,0082
300-12TR	0,0082
300-12TU	0,0082
300-18TU	0,0082
300-24TV	0,0082
300-27TH	0,0082
400-3TN	0,0061
400-6TN	0,0061
400-6TR	0,0061
400-12TR	0,0061
400-18TU	0,0061

30-12T	0,0452	←	BN 35-6L 0.0253X94=2.3782
35-6L	0,0253		

Derivation of the NPSH value:

Faktor = Q × c

Q capacity US GPM

c constant

Take NPSH value depending on the calculated factor from NPSH curve (refer to sheet 2) and add a 1,5ft safety margin.

NPSH = f (Faktor) + 1,5ft

NPSH = f (Faktor) sheet 2

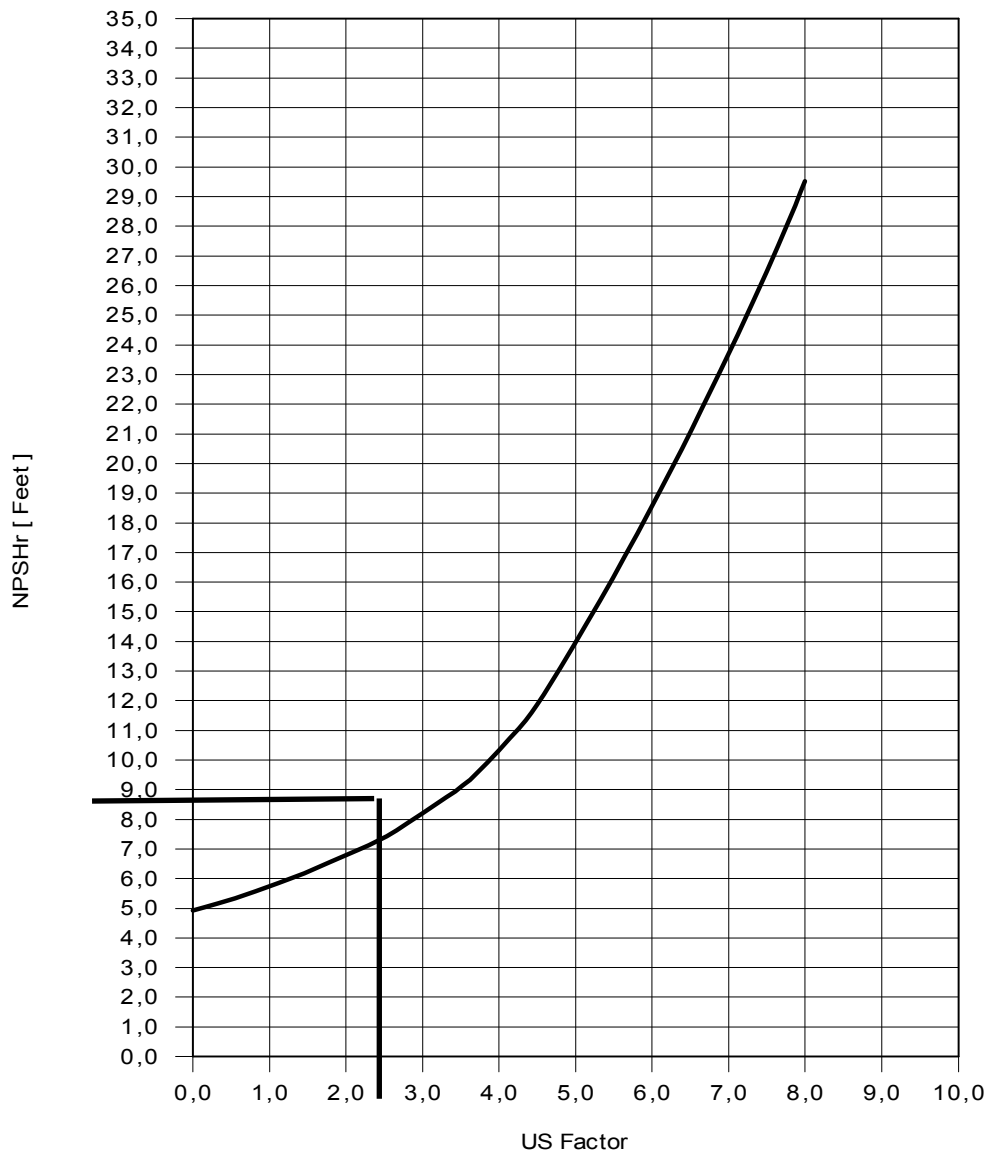



HELICAL IN-LINE

PERFORMANCE SPECIFICATIONS

Configuration: concentric
 Integral motor HP (min./ max.): 0.16 / 200
 Integral motor kW (min./ max.): 0.12 / 160
 Typical efficiency: 98.5%
 # of gear reductions: 1 to 6

MOUNTING STYLES

Footed housing style: standard
 B5 flange outside diameter range [in]: 4.72 to 21.65
 B5 flange outside diameter range [mm]: 120 to 550
 B14 flange outside diameter range [in]: 3.54 to 7.87
 B14 flange outside diameter range [mm]: 90 to 200

OPTIONS

Custom adapter flange
 Flange pilot removed

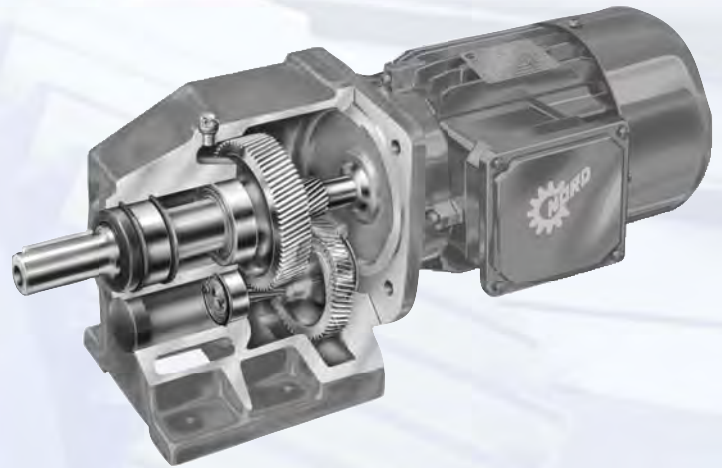

RATIO AND SPEED

Minimum standard ratio: 1.24:1
 Maximum standard ratio: 13304.45:1
 Minimum output speed from 1750 rpm motor: 0.13 rpm
 Maximum output speed from 1750 rpm motor: 1411 rpm

Unit Size	Torque Max.		Ratio Range Min.Max.	Shaft Diameter		Unit Size	Torque Max.		Ratio Range Min.Max.	Shaft Diameter	
	[lb-in]	[Nm]		[in]	[mm]		[lb-in]	[Nm]		[in]	[mm]
SK 02	876	99	2.95 - 73.06	0.750	20	SK 51	4,354	492	1.24 - 13.27	1.625	40
SK 03	974	110	65.50 - 313.11	0.750	20	SK 52	17,912	2,024	2.78 - 86.92	2.250	55
SK 11	513	58	1.35 - 9.11	1.000	20	SK 53	19,753	2,232	58.94 - 728.20	2.250	55
SK 12	1,628	184	2.96 - 72.63	1.000	25	SK 62	27,612	3,120	2.97 - 48.73	2.500	65
SK 13	1,717	194	68.40 - 420.83	1.000	25	SK 63	32,745	3,700	17.37 - 372.21	2.500	65
SK 21	681	77	1.46 - 10.20	1.250	25	SK 72	41,666	4,708	2.76 - 43.71	3.000	75
SK 22	3,310	374	2.79 - 86.30	1.250	30	SK 73	50,003	5,560	18.00 - 205.61	3.000	75
SK 23	3,009	340	64.80 - 516.65	1.250	30	SK 82	64,127	7,246	2.89 - 48.82	3.500	90
SK 31	1,637	185	1.33 - 10.20	1.625	30	SK 83	81,243	9,180	21.04 - 216.61	3.500	90
SK 32	6,284	710	2.96 - 81.27	1.625	40	SK 92	93,359	10,775	3.51 - 35.47	4.250	110
SK 33	5,947	672	88.18 - 740.37	1.625	40	SK 93	123,900	14,000	19.12 - 187.89	4.250	110
SK 41	2,567	290	1.41 - 14.80	1.375	35	SK 102	153,698	17,367	4.28 - 38.81	5.250	130
SK 42	11,009	1,244	3.02 - 105.08	1.875	45	SK 103	204,966	23,160	21.19 - 207.47	5.250	130
SK 43	11,497	1,299	40.98 - 1071.82	1.875	45						

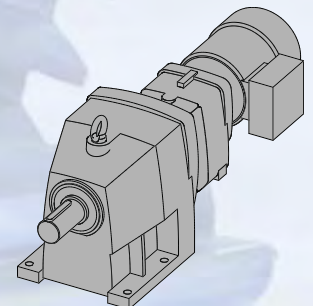
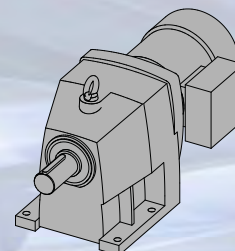
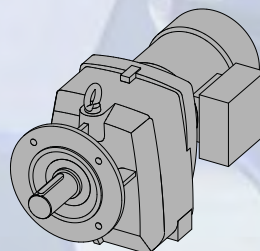
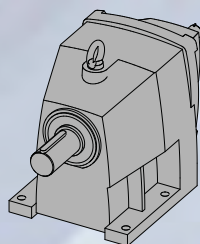
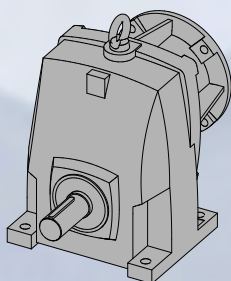



SHAFT DATA

Input and output shaft material:ASI 1045 or 4140
 Input and output shaft key dimensions [in]:according to ANSI B17
 Input and output shaft key dimensions [mm]:according to DIN 747
 Output shaft drill and tap:standard

OPTIONS

Custom shaft diameters
 Custom spline
 Cross drilled holes
 304 stainless steel

MOTOR MOUNTING

Integral motor:1/6 to 250 HP
 C-face adapter frame size range:56C to 360TC
 IEC adapter (B5) frame size range:IEC 63 to IEC 315
 Sugar scoop motor availability:56 to 365T
 Top mount platform motor availability:56 to 405T

OPTIONS

Custom motor adapter
 Custom coupling diameter

GEARING

Quality rating on gears:up to AGMA Class 13
 Minimum hardness of steel gears:58 Rockwell C
 Hard finishing of gear teeth:grinding or skive hob
 Drop forged gear blanks:standard
 Momentary overload capacity:275%
 Hunting tooth ratios:standard

HOUSING

Typical housing material:Class 35 gray iron
 Machining method:single setup
 Main housing design:UNICASE™ one piece
 Seal carrier:direct to main housing
 Housing torsional stiffness:exceptional
 Housing wall section:thick
 Casting sealing method:dip seal

BEARINGS

Bearing quality:ABEC-1
 Standard output bearing:ball or spherical
 Heavy-duty output bearing:heavy-duty spherical

INTERNAL PARTS ASSEMBLY

Assembly method:heavy press fit
 Reversing duty:standard
 Typical backlash range [arc minutes]:10 to 17

LUBRICANT AND SEALING COMPONENTS

Factory filled lubricant type:ISO 220 mineral oil
 Typical breather vent style:AUTOVENT
 Output seal design:QUADRILIP™ Seal System
 Output shaft oil seals:1 double lip and 1 single lip
 oil seal lip material:nitrile rubber
 Oil seal to housing gasket:nitrile rubber

OPTIONS

Custom synthetic lubricating oil
 Custom temperature lubricating oil
 Fluid grease lubricant
 Food grade lubricating oil
 Long term storage preparation
 Magnetic drain plug
 Bullseye sight glass
 Custom drain plug
 Fluorinated rubber oil seal material
 Custom oil seals

ENVIRONMENTAL PROTECTION

Exterior primer coverage:all metal exterior surfaces
 Paint type:Water Based Resin
 Paint additive:316 stainless steel flakes
 USDA incidental contact exposure:H1

OPTIONS

NSD+ protection • custom paint
 High pressure washdown IP66 oil seals:custom order
 Shaft seal covers:custom order

MECHANICAL VARIABLE SPEED COMPATIBILITY

HP range with TITAN™ belt box:0.33 to 150
 Speed range with TITAN™ belt box:8.9 to 1308
 HP range with NORDISC®traction drive:0.25 to 7.5
 Speed range with NORDISC®traction drive:0.5 to 1621



www.nord.com

NORD Gear Corporation

National Customer Service Toll-Free: 888.314.6673
 info@nord-us.com

NORD Gear Limited

Toll-Free in Canada: 800.668.4378
 info@nord-ca.com

WEST

Corona, CA (Los Angeles)
 Phone: 608.849.0190

MIDWEST

Wauwaukee, WI (Madison)
 Phone: 608.849.7300

EAST

Charlotte, NC
 Phone: 608.849.0140

CANADA

Brampton, ON (Toronto)
 Phone: 905.796.3606



STANDARD REDUCER FEATURES

> QUADRILIP™ shaft seal system – consisting of 2 spring compression lips, 1 trash guard lip and 1 collector grease pack – keeps contaminants out and lubricant inside the gear case.

> AUTOVENT breather seals dirt and moisture out while allowing the gear case to breathe during startup and cool down.

> Standard paint has 316 stainless steel flakes with a flexible and tough resin binder. USDA incidental contact H1 approval provides excellent moisture and corrosion resistance.

> Primer paint covers all exterior surfaces of the housing, providing excellent base corrosion protection.

> Shaft material is wear-resistant, high carbon steel that provides stable non-grooving surface for oil seal contact.

> Housing interior seal coating locks in casting sand, fills in processing blemishes eliminating leak paths, and protects against moisture damage to inside of gear case.

> UNICASE™ one-piece housing is torsionally stiff, machined in one pass, has extreme accuracy, and eliminates the split case leakage path.

> Outside diameter of oil seals is nitrile rubber. Direct connection of seal to housing eliminates bolt-on covers and centers the seal, eliminating the potential for leakage.



Helical Speed Reducers

Double reduction, for assembly with NEMA C-face motors

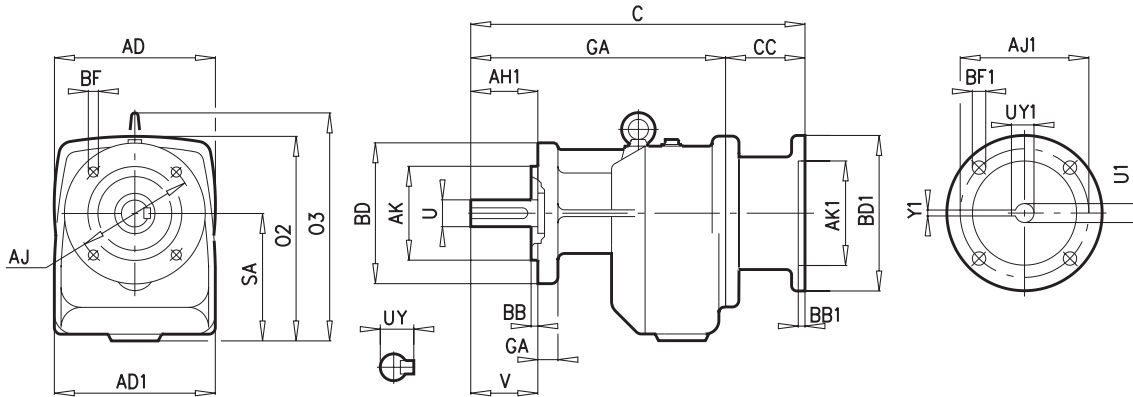
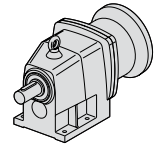

Type	Mounting dimensions (flange)			Outline dimensions								
	AJ	BB	BF	AD	AD1	AH1	C	CC	O2	O3	QA	SA
SK 02 F - 56 C	5.12	0.14	0.35	5.12	5.12	1.50	11.59	4.50	6.77	—	7.09	3.50
- 140 TC	4.331	6.30	0.39				11.59	4.50	6.77			
SK 12 F - 56 C	5.12	0.14	0.35	5.12	5.32	2.13	12.73	4.50	7.44	—	8.23	4.17
- 140 TC							12.73	4.50	7.44			
- 180 TC	4.331	6.30	0.39				13.88	5.65	8.70			
SK 22 F - 56 C	6.50	0.14	0.43	7.87	7.28	2.75	14.40	4.60	8.86	—	9.80	4.92
- 140 TC							14.40	4.60	8.86			
- 180 TC	5.118	7.87	0.47				16.40	6.60	9.45			
SK 32 F - 56 C	8.46	0.16	0.55	7.87	8.27	3.25	16.47	4.60	10.04	11.50	11.87	6.10
- 140 TC							16.47	4.60	10.04			
- 180 TC	7.087	9.84	0.63				18.47	6.60	10.63			
- 210 TC							18.47	6.60	10.63			
SK 42 F - 56 C	8.46	0.16	0.55	9.84	8.47	3.50	18.08	4.30	11.81	12.87	13.78	6.89
- 140 TC							18.08	4.30	11.81			
- 180 TC	7.087	9.84	0.63				21.68	7.90	11.81			
- 210 TC							21.68	7.90	11.81			
- 250 TC							21.68	7.90	11.81			
SK 52 F - 56 C	10.43	0.16	0.55	9.84	10.24	4.00	20.11	4.30	13.27	15.16	15.81	8.35
- 140 TC							20.11	4.30	13.27			
- 180 TC	9.055	11.81	0.79				23.71	7.90	13.27			
- 210 TC							23.71	7.90	13.27			
- 250 TC							23.71	7.90	13.27			
- 280 TC							24.35	8.54	13.27			



NEMA	AJ1	AK1	BB1	BD1	BF1	U1	UY1	Y1
56 C	5.88	4.500	0.16	6.54	0.43	0.625	0.71	0.188
140 TC	5.88	4.500	0.16	6.54	0.43	0.875	0.96	0.188
180 TC	7.25	8.500	0.23	9.17	0.59	1.125	1.24	0.250
210 TC	7.25	8.500	0.23	9.17	0.59	1.375	1.52	0.312
250 TC	7.25	8.500	0.23	9.17	0.59	1.625	1.80	0.375
280 TC	9.00	10.500	0.23	13.78	0.59	1.875	2.10	0.500

Shaft dimensions	SK 02 F	SK 12 F	SK 22 F	SK 32 F	SK 42 F	SK 52 F
U	0.750	1.000	1.250	1.625	1.875	2.250
UY	0.83	1.11	1.36	1.79	2.09	2.47
V	1.50	2.13	2.75	3.25	3.50	4.00
Key	3/16 x 3/16 x 1-1/4	1/4 x 1/4 x 1-5/8	1/4 x 1/4 x 2-1/4	3/8 x 3/8 x 2-3/4	1/2 x 1/2 x 2-3/4	1/2 x 1/2 x 3-1/4

Additional flange sizes available	SK 02 F	SK 12 F	SK 22 F	SK 32 F	SK 42 F	SK 52 F
AJ	3.94 / 4.53	3.94 / 4.53	5.12	6.50	6.50	8.46
AK	3.150 / 3.740	3.150 / 3.740	4.331	5.118	5.118	7.087
BB	0.12 / 0.12	0.12 / 0.12	0.14	0.14	0.14	0.16
BD	4.72 / 5.51	4.72 / 5.51	6.30	7.87	7.87	9.84
BF	0.28 / 0.35	0.28 / 0.35	0.35	0.43	0.43	0.55
GA	0.39 / 0.39	0.39 / 0.39	0.39	0.47	0.55	0.63

Technical design may be subject to change. DXF files available upon request.

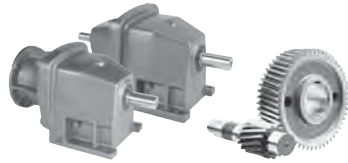

SK 41E , SK 42 NEMA-C + W Ratings & Combinations



Model Type	Gear Ratio	Output Speed n_2 1750 rpm [rpm]	Output Torque* T_{2max} [lb-in]	Maximum input power [◇] Solid input shafts type "W"				NEMA C-Face* Available Combinations								
				Input Speed				56C	140TC	180TC	210TC	250TC	280TC	320TC	360TC	
				1750 rpm [hp]	1150 rpm [hp]	875 rpm [hp]	580 rpm [hp]									
SK 41E	1.41	1241	1593	20.00	13.20	10.00	6.60			X	X	X				
	1.50	1167	1682	20.00	13.20	10.00	6.60			X	X	X				
	1.63	1074	1770	20.00	13.20	10.00	6.60			X	X	X				
	1.82	962	1974	20.00	13.20	10.00	6.60	X	X	X	X	X				
	2.14	818	2195	20.00	13.20	10.00	6.60	X	X	X	X	X				
	2.50	700	2398	20.00	13.20	10.00	6.60	X	X	X	X	X				
	3.08	568	2567	20.00	13.20	10.00	6.60	X	X	X	X	X	X			
	3.42	512	1239	10.07	6.64	5.03	3.32	X	X	X	X					
	3.88	451	1283	9.18	6.06	4.59	3.03	X	X	X	X*					
	4.29	408	1372	8.88	5.86	4.44	2.93	X	X	X	X*					
	5.27	332	1726	9.09	6.00	4.55	3.00			X	X*					
	7.18	244	1682	6.51	4.30	3.25	2.15			X	X*					
	10.55	166	1682	4.43	2.92	2.21	1.46	X	X	X*						
	14.80	118	1177	2.20	1.45	1.10	0.73	X	X							
SK 42	3.02	579	5345	20.00	13.20	10.00	6.60			X	X	X				
	3.21	545	5487	20.00	13.20	10.00	6.60			X	X	X				
	3.50	500	5885	20.00	13.20	10.00	6.60			X	X	X				
	3.89	450	6195	20.00	13.20	10.00	6.60	X	X	X	X	X				
	4.58	382	6832	20.00	13.20	10.00	6.60	X	X	X	X	X				
	4.79	365	8496	20.00	13.20	10.00	6.60			X	X	X				
	5.10	343	8708	20.00	13.20	10.00	6.60			X	X	X				
	5.35	327	7230	20.00	13.20	10.00	6.60	X	X	X	X	X				
	5.75	304	10036	20.00	13.20	10.00	6.60			X	X	X				
	6.19	283	9514	20.00	13.20	10.00	6.60	X	X	X	X	X				
	6.65	263	10293	20.00	13.20	10.00	6.60			X	X	X				
	7.28	240	9523	20.00	13.20	10.00	6.60	X	X	X	X	X				
	8.50	206	9523	20.00	13.20	10.00	6.60	X	X	X	X	X				
	10.20	172	10328	20.00	13.20	10.00	6.60	X	X	X	X	X				
	12.28	143	10585	20.00	13.20	10.00	6.60	X	X	X	X	X				
	14.38	122	10248	19.84	13.09	9.92	6.55	X	X	X	X	X*				
	15.12	116	11009	20.00	13.20	10.00	6.60	X	X	X	X	X				
	17.71	99	10496	16.49	10.88	8.24	5.44	X	X	X	X	X*				
	17.92	98	8832	13.73	9.06	6.87	4.53			X	X					
	21.50	81	10293	13.23	8.73	6.61	4.37			X	X					
	21.87	80	9700	12.31	8.13	6.16	4.06	X	X	X	X	X*				
	24.41	72	7593	8.67	5.73	4.34	2.86			X	X*					
	24.67	71	7885	8.88	5.86	4.44	2.93	X	X	X	X*					
	25.88	68	11001	11.87	7.83	5.93	3.92			X	X					
29.29	60	9036	8.60	5.68	4.30	2.84			X	X*						
30.46	57	9540	8.63	5.69	4.31	2.85	X	X	X	X*						
35.25	50	10868	8.62	5.69	4.31	2.85			X	X*						
41.29	42	10496	6.99	4.62	3.50	2.31			X	X*						
50.98	34	9717	5.24	3.46	2.62	1.73			X	X*						
60.66	29	8885	4.09	2.70	2.04	1.35	X	X	X*							
74.87	23	9558	3.49	2.30	1.74	1.15	X	X	X*							
85.10	21	7045	2.35	1.55	1.17	0.77	X	X								
105.08	17	7629	2.06	1.36	1.03	0.68	X	X								

* Caution - The motor power may exceed the gear unit's mechanical torque capacity
[◇] The mechanical power limit of the solid input shaft type "W" may limit the reducer rating.
 All ratings are mechanical. See page 14 for thermal considerations.

lb	W	56C	140TC	180TC	210TC	250TC
SK 41E	101	90	106	106	137	159
SK 42	143	132	148	148	179	201

PARTS LIST

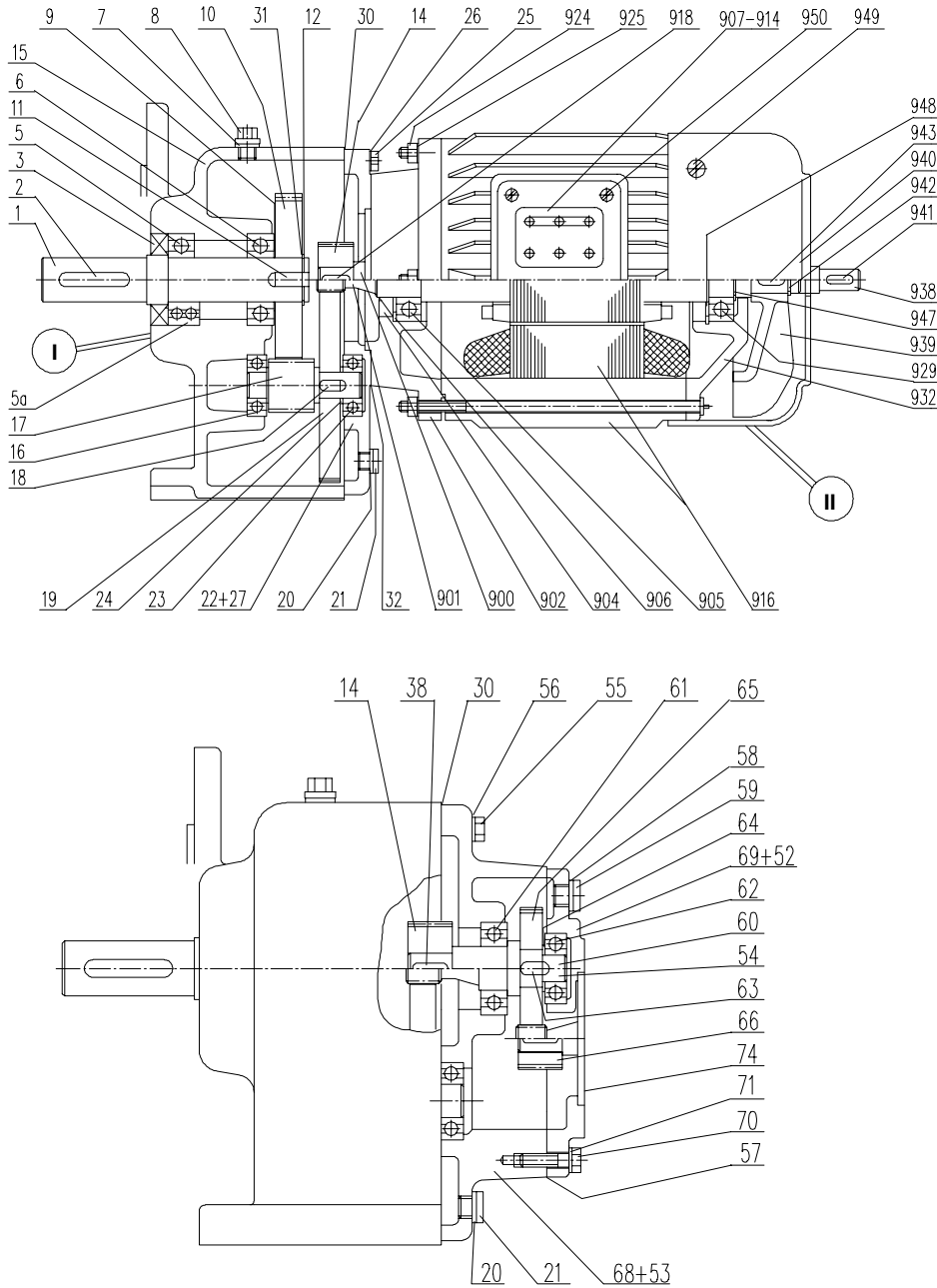

- 1 Output shaft
- 2 Key
- 3 Shaft seal
- 5 Output shaft bearing, normal
- 5a Output shaft bearing, reinforced
- 6 Output shaft bearing
- 7 Seal
- 8 Vent screw
- 9 Shim
- 10 Driven gear
- 11 Key
- 12 Circlip
- 14 Driving pinion
- 15 Gear case
- 16 Pinion shaft bearing
- 17 Driven pinion
- 18 Key
- 19 Driving gear
- 20 Seal
- 21 Plug
- 22 Gear case cover
- 23 Pinion shaft bearing
- 24 Shim
- 25 Hexagon bolt
- 26 Washer
- 27 Spiral pin
- 30 Seal
- 31 Shim
- 32 Seal
- 52 Spiral pin
- 53 Spiral pin
- 54 Intermediate shaft, gearcut
- 55 Hexagon bolt
- 56 Washer
- 57 Seal
- 58 Seal
- 59 Plug
- 60 Intermediate shaft, plain
- 61 Grooved ball bearing
- 62 Grooved ball bearing
- 63 Key
- 64 Shim
- 65 Driving gear
- 66 Driving pinion
- 68 Gear case 3rd.-red.
- 69 Gear case cover
- 70 Hexagon bolt
- 71 Washer
- 74 Seal
- 900 Rotor with shaft, plain
- 901 Rotor with shaft, gearcut
- 902 End shield A
- 904 Shaft seal
- 905 Bearing A
- 906 Bearing shim
- 907 Terminal box frame
- 908 Terminal box cover
- 909 Terminal box frame gasket
- 910 Terminal box cover gasket
- 911 Terminal board
- 914 cable entry gland
- 916 Stator case
- 918 Key
- 924 Collar bolt
- 925 Hexagonal nut
- 929 Bearing B
- 932 End shield B
- 938 Second motor shaft end
- 939 Fan
- 940 Fan cover
- 941 Key
- 942 Circlip
- 943 Key
- 947 Circlip
- 948 Circlip
- 949 Oval flat-head bolt
- 950 Oval flat-head bolt

RECOMMENDED SPARE PARTS

Bearings – all Gaskets – all Shims – all
 Seals – all Seal Plugs – all

IMPORTANT!

When ordering parts, it is necessary to have the *NORD SERIAL NUMBER* from the unit the parts are for. The serial number will dictate the correct parts for that particular unit. The gearbox nameplate will have the serial number on it.

Lubrication



Lubrication Types

Proper gearbox lubrication is essential in order to reduce friction, heat, and component wear. Lubricants reduce heat and wear by inserting a protective “fluid boundary” between mating parts and preventing direct metal to metal contact. Lubricants also help prevent corrosion and oxidation, minimize foam, improve heat transfer, optimize reducer efficiency, absorb shock loads and reduce noise.

Mounting position not only determines the proper fill-level but may also have some effect on final reducer assembly. If considering any mounting positions that are not shown as catalog-standard options, it is critical that the customer consult with NORD prior to ordering. Unless otherwise specified, NORD supplies most all gear units (*) factory-filled with the standard lubrication type and the appropriate amount of lubricating oil.

* Gear units SK10282, SK10382, SK11282, SK11382, SK12382, and SK9096.1 are supplied without oil.

Standard Oil Lubricants

Gear Unit Type	Ambient Temperature	Oil Type	ISO Viscosity	Manufacturer Brand / Type
Helical-Inline, Parallel-Shaft, & Helical-Bevel	-4 to 104 °F (-20 to 40 °C)	MIN-EP	VG 220	Shell / Omala 220 ♣
	-40 to 140 °F (-40 to 60 °C)	PAO	VG 220	Mobil SHC 630 ♣
	23 to 104 °F (-5 to 40 °C)	FG	VG 220	Shell / FM 220 ♣
Helical-Worm	-22 to 122 °F (-30 to 50 °C)	PAO	VG 680	Mobil SHC 636 ♣

Optional Oil Lubricants

Gear Unit Type	Ambient Temperature	Oil Type	ISO Viscosity	Manufacturer Brand / Type
Helical-Inline, Parallel-Shaft, & Helical-Bevel	-31 to 176 °F (-35 to 80 °C)	PAO	VG 460	Mobil SHC 634
	-40 to 77 °F (-40 to 25 °C)	PAO	VG 150	Mobil SHC 629
	-40 to 140 °F (-40 to 60 °C)	FG-PAO	VG 220	Shell / Cassida GL 220
Helical-Worm	-40 to 122 °F (-40 to 50 °C)	FG-PAO	VG 460	Shell / Cassida GL 460

Standard Bearing Grease Lubricants

Grease Type / Thickener	Ambient Temperature	NLGI Grade	Manufacturer Brand / Type
Standard (Li-Complex)	-22 to 140 °F (-30 to 60 °C)	NLGI 2	Shell Albida EP LC2 ♣
High Temp (Polyurea)	-13 to 176 °F (-25 to 80 °C)	NLGI 2	Mobil Polyrex EP 2 ♣
Food-Grade (Al-Complex)	-13 to 104 °F (-25 to 40 °C)	NLGI 2	Mobil Grease FM 222 ♣

♣ Stocked Lubricant

Oil Formulation Codes

MIN-EP	Mineral Oil with EP Additive
PAO	Synthetic Polyalphaolefin Oil
PG	Synthetic Polyglycol Oil
FG	Food-Grade Oil
FG-PAO	Food-Grade, Synthetic Polyalphaolefin Oil

Important Notes

- In worm gears avoid using (EP) gear oils that contain sulfur-phosphorous chemistries, as these additives can react adversely with bronze worm gears and accelerate wear.
- Food grade lubricants must be in compliance with FDA 212 CFR 178.3570 and qualify as a NSF-H1 lubricant. Please consult with lubrication manufacture for more information.
- When making a lubrication change, check with the lubrication supplier to assure compatibility and to obtain recommended cleaning or flushing procedures.
- Do not mix different oils with different additive packages or different base oil formulation types. Polyglycol (PG) oils are not miscible with other oil types and should never be mixed with mineral oil, or Polyalphaolefin (PAO) oil.
- Please Consult NORD if considering cold-temperature oils below an ISO Viscosity VG100 or lower.

In-line Foot Mount Positions & Oil Fill Quantities

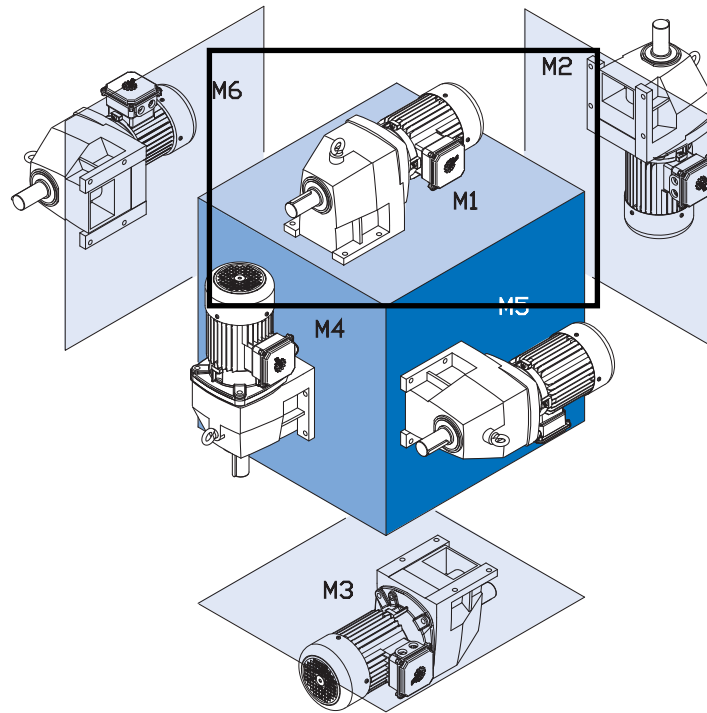

Mounting Position	M1		M2		M3		M4		M5		M6	
	Quarts	Liters	Quarts	Liters	Quarts	Liters	Quarts	Liters	Quarts	Liters	Quarts	Liters
SK02	0.16	0.15	0.63	0.60	0.74	0.70	0.63	0.60	0.42	0.40	0.42	0.40
SK03	0.32	0.30	1.06	1.00	0.85	0.80	0.95	0.90	0.63	0.60	0.63	0.60
SK11E	0.26	0.25	0.53	0.50	0.58	0.55	0.42	0.40	0.37	0.35	0.37	0.35
SK12	0.26	0.25	0.79	0.75	0.90	0.85	0.79	0.75	0.53	0.50	0.53	0.50
SK13	0.63	0.60	1.32	1.25	1.16	1.10	1.27	1.20	0.74	0.70	0.74	0.70
SK21E	0.63	0.60	1.27	1.20	1.27	1.20	1.06	1.00	1.06	1.00	1.06	1.00
SK22	0.53	0.50	1.90	1.80	2.11	2.00	1.90	1.80	1.43	1.35	1.43	1.35
SK23	1.37	1.30	2.54	2.40	2.43	2.30	2.48	2.35	1.69	1.60	1.69	1.60
SK31E	1.16	1.10	2.85	2.70	2.33	2.20	2.43	2.30	1.80	1.70	1.80	1.70
SK32	0.95	0.90	2.64	2.50	3.17	3.00	3.07	2.90	2.11	2.00	2.11	2.00
SK33N	1.69	1.60	3.07	2.90	3.38	3.20	3.91	3.70	2.43	2.30	2.43	2.30
SK41E	1.80	1.70	2.75	2.60	3.49	3.30	2.64	2.50	2.75	2.60	2.75	2.60
SK42	1.37	1.30	4.76	4.50	4.76	4.50	4.55	4.30	3.38	3.20	3.38	3.20
SK43	3.17	3.00	5.92	5.60	5.50	5.20	6.98	6.60	3.81	3.60	3.81	3.60
SK51E	2.33	2.20	4.65	4.40	4.97	4.70	4.23	4.00	3.59	3.40	3.59	3.40
SK52	2.64	2.50	7.40	7.00	7.19	6.80	7.19	6.80	5.39	5.10	5.39	5.10
SK53	4.76	4.50	9.20	8.70	8.14	7.70	9.20	8.70	6.34	6.00	6.34	6.00
SK62	6.87	6.50	15.9	15.0	13.7	13.0	16.9	16.0	15.9	15.0	15.9	15.0
SK63	13.7	13.0	15.3	14.5	15.3	14.5	16.9	16.0	13.7	13.0	13.7	13.0
SK72	10.6	10.0	24.3	23.0	19.0	18.0	27.5	26.0	24.3	23.0	24.3	23.0
SK73	21.7	20.5	21.1	20.0	23.8	22.5	28.5	27.0	21.1	20.0	21.1	20.0
SK82	14.8	14.0	37.0	35.0	28.5	27.0	46.5	44.0	33.8	32.0	33.8	32.0
SK83	31.7	30.0	32.8	31.0	35.9	34.0	39.1	37.0	34.9	33.0	34.9	33.0
SK92	26.4	25.0	77.1	73.0	49.7	47.0	80.3	76.0	55.0	52.0	55.0	52.0
SK93	56.0	53.0	74.0	70.0	62.4	59.0	76.1	72.0	51.8	49.0	51.8	49.0
SK102	38.1	36.0	83.5	79.0	69.8	66.0	107.8	102	75.1	71.0	75.1	71.0
SK103	78.2	74.0	75.1	71.0	78.2	74.0	102.5	97.0	70.8	67.0	70.8	67.0

Oil Plugs

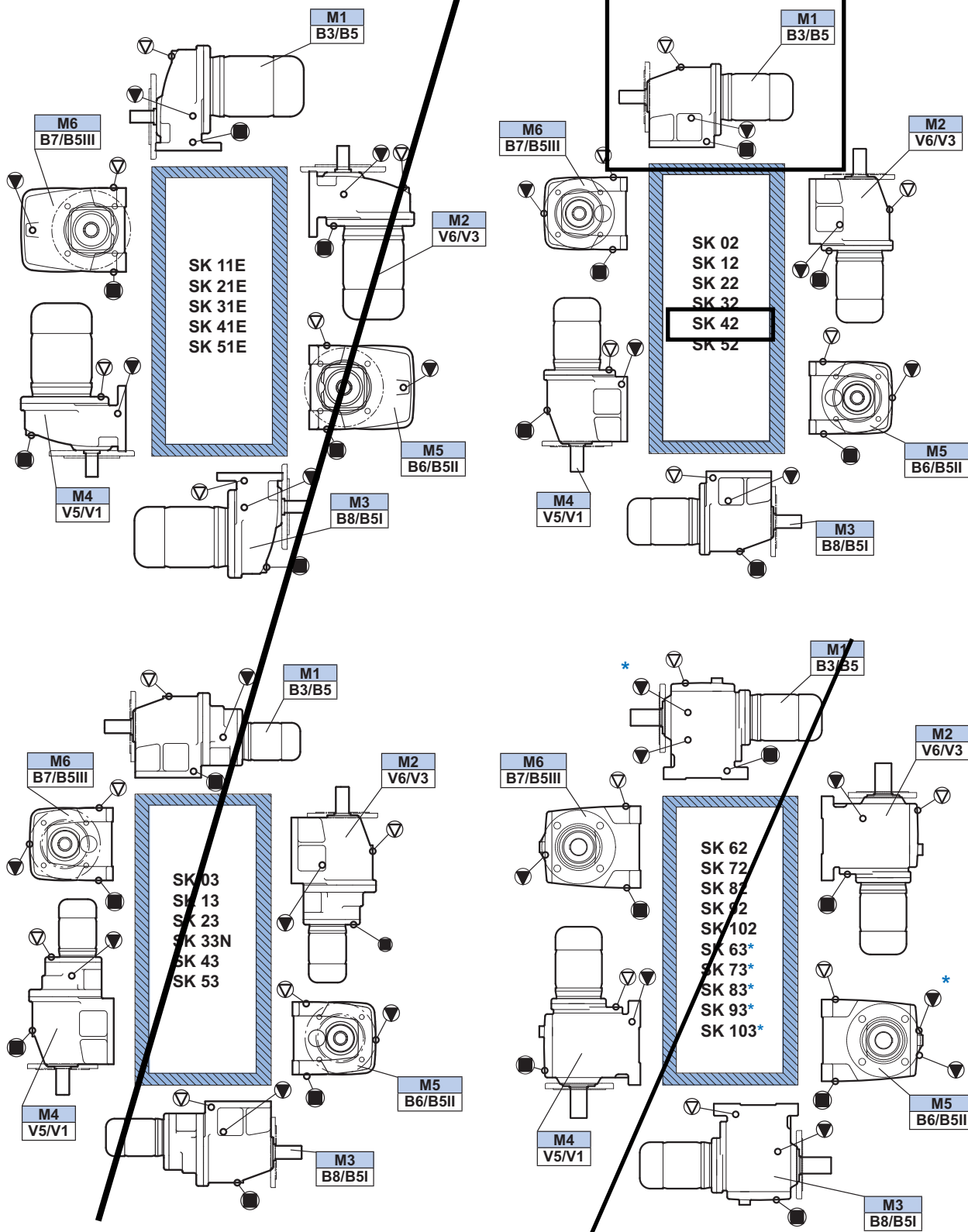
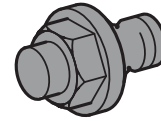

▽ = Vent ▼ = Oil Level ■ = Oil Drain

SERVICE



Helical In-line Weights - Reducer



Approximate Weights [lb]

Type	W	56C	140TC	180TC	210TC	250TC	280TC	320TC	360TC
SK 02	26	44	44	–	–	–	–	–	–
SK 03	35	–	–	–	–	–	–	–	–
SK 11	35	35	49	–	–	–	–	–	–
SK 12	48	48	57	–	–	–	–	–	–
SK 13	46	–	–	–	–	–	–	–	–
SK 12/02	49	49	–	–	–	–	–	–	–
SK 21	49	46	46	59	–	–	–	–	–
SK 22	64	73	73	77	–	–	–	–	–
SK 23	68	86	86	–	–	–	–	–	–
SK 22/02	77	93	93	–	–	–	–	–	–
SK 31	59	62	62	66	–	–	–	–	–
SK 32	88	90	90	95	–	–	–	–	–
SK 33 N	95	103	103	–	–	–	–	–	–
SK 32/12	106	115	115	132	–	–	–	–	–
SK 41	101	91	88	92	130	159	–	–	–
SK 42	143	138	132	143	174	201	–	–	–
SK 43	154	152	152	156	–	–	–	–	–
SK 42/12	143	148	148	170	–	–	–	–	–
SK 51	121	105	105	117	147	150	199	–	–
SK 52	207	169	169	174	205	207	285	–	–
SK 53	227	185	185	189	–	–	–	–	–
SK 52/12	207	179	179	234	–	–	–	–	–
SK 62	377	–	–	317	354	392	392	567	567
SK 63	328	295	288	299	330	332	405	–	–
SK 63/22	348	329	329	333	–	–	–	–	–
SK 63/23	353	335	335	–	–	–	–	–	–
SK 72	529	–	–	440	477	515	515	721	721
SK 73	551	–	–	416	453	491	491	743	743
SK 73/22	527	452	452	456	–	–	–	–	–
SK 73/32	551	553	553	558	571	–	–	–	–
SK 82	880	–	–	666	702	741	741	962	962
SK 83	787	–	–	631	669	706	706	979	979
SK 83/32	787	723	723	728	741	–	–	–	–
SK 83/42	842	837	837	848	879	906	–	–	–
SK 92	1268	–	–	–	–	1215	1215	1350	1350
SK 93	1182	–	–	1184	1184	1239	1239	1374	1374
SK 93/42	1237	1226	1226	1272	1272	1294	–	–	–
SK 93/52	1301	–	–	1276	1306	1308	1308	–	–
SK 102	1821	–	–	–	–	–	1702	1837	1837
SK 103	1775	–	–	1667	1667	1722	1722	1857	1857
SK 103/52	1784	1773	1773	1819	1819	1840	1860	–	–

Above weights are approximate. Depending upon ratio, oil quantity and optional equipment, reducer weights may be different than shown. Exact weights can be obtained after the unit is fully assembled.



No.:

Date: 30-MAY-2012

Customer :

TECHNICAL PROPOSAL
Three-phase induction motor - Squirrel cage rotor

Product line : TEFC - W22 Super Premium Efficiency

Catalog Number :

List Price :

Notes:

Performed by:

Checked:



No.:

Date: 30-MAY-2012

DATA SHEET

Three-phase induction motor - Squirrel cage rotor

Customer :
Product line : TEFC - W22 Super Premium Efficiency

Frame : 184T
Output : 5 HP
Frequency : 60 Hz
Poles : 2
Full load speed : 3505
Slip : 2.64 %
Voltage : 208-230/460 V
Rated current : 13.2-12.0/5.99 A
Locked rotor current : 98.2/49.1 A
Locked rotor current (I_L/I_n) : 8.2
No-load current : 4.80/2.40 A
Full load torque : 7.39 lb.ft
Locked rotor torque : 240 %
Breakdown torque : 350 %
Design : A
Insulation class : F
Temperature rise : 80 K
Locked rotor time : 30 s (hot)
Service factor : 1.25
Duty cycle : S1
Ambient temperature : -20°C - +40°C
Altitude : 1000
Degree of Protection : IP55
Approximate weight : 95 lb
Moment of inertia : 0.22330 sq.ft.lb
Noise level : 69 dB(A)

	D.E.	N.D.E.	Load	Power factor	Efficiency (%)
Bearings	6207 ZZ	6206 ZZ	100%	0.86	90.2
Regreasing interval	---	---	75%	0.83	88.5
Grease amount	---	---	50%	0.73	87.5

Notes:

Performed by

Checked



No.:

Date: 30-MAY-2012

PERFORMANCE CURVES RELATED TO RATED OUTPUT Three-phase induction motor - Squirrel cage rotor

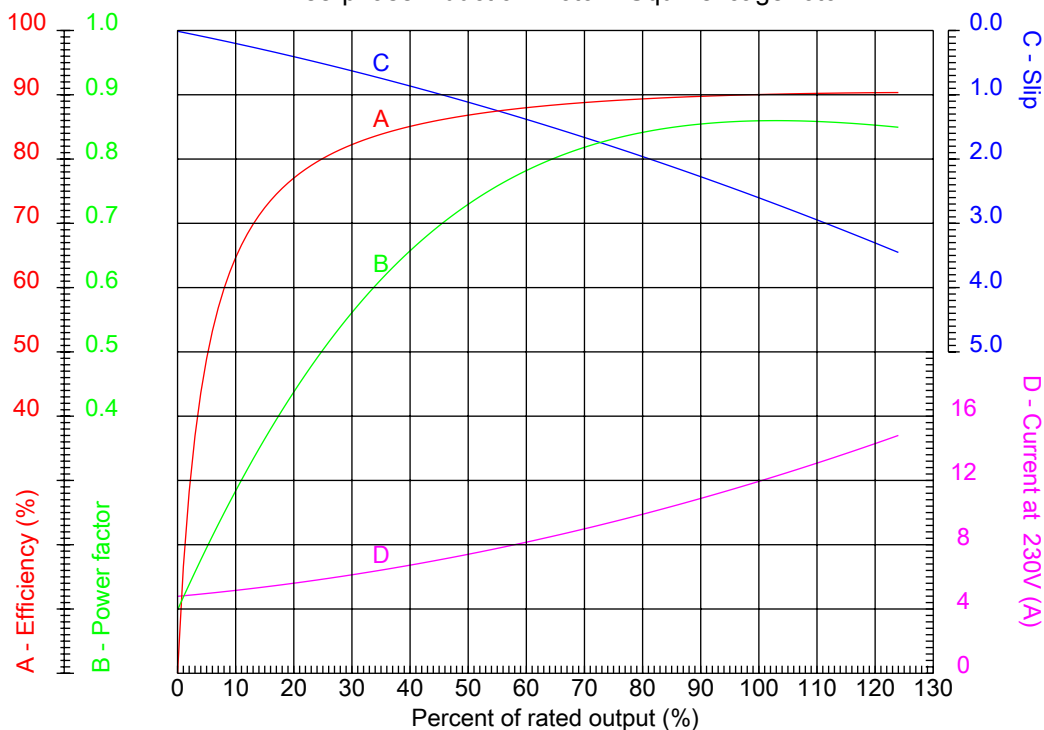

Customer :
Product line : TEFC - W22 Super Premium Efficiency

Frame : 184T	Locked rotor current (I _L /I _n) : 8.2
Output : 5 HP	Duty cycle : S1
Frequency : 60 Hz	Service factor : 1.25
Full load speed : 3505	Design : A
Voltage : 208-230/460 V	Locked rotor torque : 240 %
Rated current : 13.2-12.0/5.99 A	Breakdown torque : 350 %
Insulation class : F	

Notes:

Performed by

Checked



No.:

Date: 30-MAY-2012

CHARACTERISTIC CURVES RELATED TO SPEED Three-phase induction motor - Squirrel cage rotor

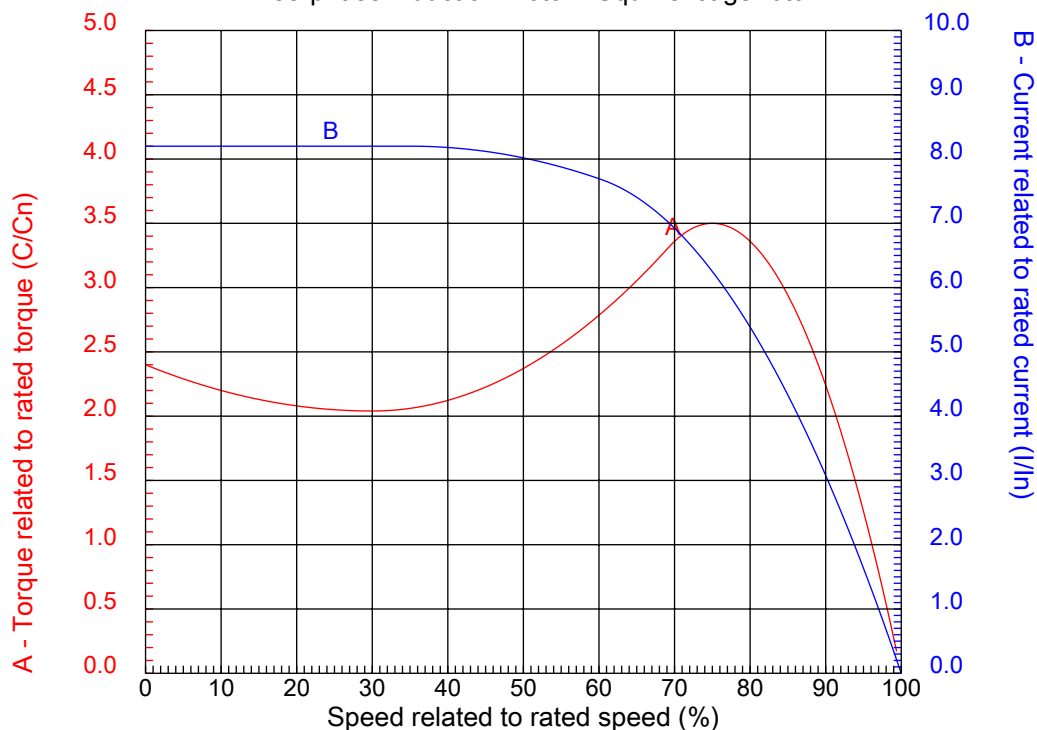

Customer :
Product line : TEFC - W22 Super Premium Efficiency

Frame	: 184T	Locked rotor current (I _l /I _n)	: 8.2
Output	: 5 HP	Duty cycle	: S1
Frequency	: 60 Hz	Service factor	: 1.25
Full load speed	: 3505	Design	: A
Voltage	: 208-230/460 V	Locked rotor torque	: 240 %
Rated current	: 13.2-12.0/5.99 A	Breakdown torque	: 350 %
Insulation class	: F		

Notes:

Performed by

Checked

1 2 3 4 5 6 7 8

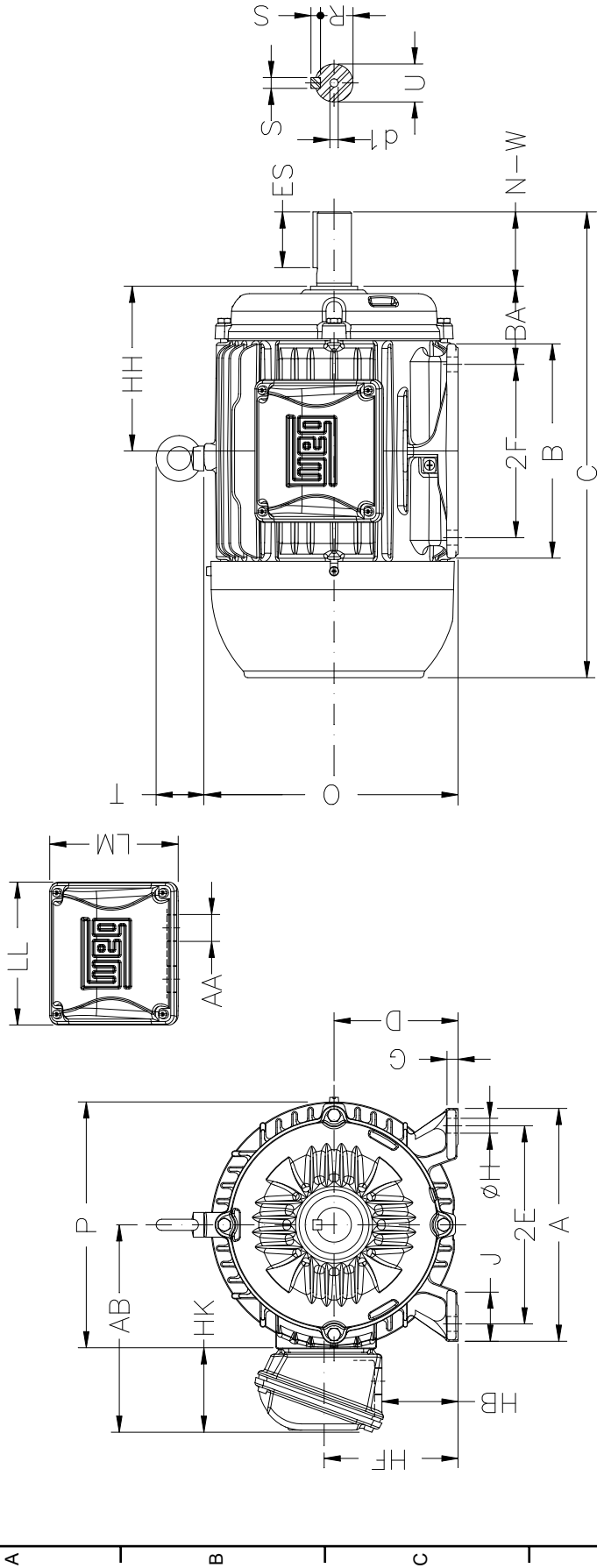

Notes:									
Performed by:									
Checked:									
Customer:									
TEFC - W22 Super Premium Efficiency									
Three-phase induction motor						30-MAY-2012			
Frame 184T - IP55									
2E	7.500	J	1.594	A	8.661	P	8.740	AB	7.559
2F	5.500	B	6.969	BA	2.750	U	1.125	N-W	2.750
ES	1.969	S	0.250	R	0.984	depth	0.250	D	4.500
G	0.394	HB	2.236	O	9.343	T	1.772	HF	4.500
HH	5.500	HK	3.110	H	0.406	C	15.860	LL	5.512
LM	5.236	AA	NPT-1"	d1	A4	d2	A4		



greater than 95%, regardless of the operating schedule. It should be highlighted that in this situation it is strongly recommended that an epoxy paint known as internal anti-corrosive painting is applied in the internal components of the motor.

More information can be obtained in section 7.3.

For all frame sizes, W22 motors can be provided with space heaters suitable for 110-127 V, 220-240 V and 380-480 V. Motors in frame sizes 586/7T and 588/9T are supplied with space heaters for 220-240 V as standard. As an option, dual voltage heaters of 110-127 / 220-240 V can be supplied for frame sizes 182T to 588/9T.

The power rating and number of space heaters fitted depends on the size of the motor as indicated in table 11 below:

Frame	Quantities	Total power rated (W)
143 to 145	1	11
182 to 184	2	22
213 to 256	2	30
284 to 326	2	38
364/5 to 404/5	2	56
444/5 to 504/5	2	140
586/7 to 588/9	2	174

Table 11 – Power and quantity of space heaters

10. Motor protections

Protections available for W22 can be classified as follows:

- Based on operating temperature
- Based on operating current.

In section 12 - Construction features it is possible to identify the type of protection for each W22 line.

10.1 Protection based on operating temperature

Continuous duty motors must be protected from overload either by a device integrated into the motor winding or via an independent protection system, usually a thermal relay with rated or setting current, equal to or below the value obtained when multiplying the power supply rated current (In), as per table 12.

Service Factor	Relay setting current
1.0 up to 1.15	In x S.F.
≥ 1.15	(In x S.F.) – 5%

Table 12 – Relay setting current referred to service factor

RTD

These are temperature detectors (figure 26) with operating principle based on the properties that some materials vary the electric resistance with the variation in temperature (usually platinum, nickel or copper).



Figure 26 - RTD

They are also fitted with calibrated resistances that vary linearly with temperature, allowing continuous reading of motor operating temperature through a monitoring display, with high precision rate and response sensitivity. The same detector can serve as alarm (with operation above the regular operating temperature) and trip (usually set up for the maximum temperature of the insulation class).

Thermistor (PTC)

These are thermal protectors consisting of semiconductor detectors with sudden variation of the resistance when reaching a certain temperature (figure 27).



Figure 27 – Thermistor (PTC)

PTC is considered a thermistor with the resistance increasing drastically to a well defined temperature figure. This sudden resistance variation blocks the PTC current, causing the output relay to operate, and the main circuit to switch-off. The thermistors are of small dimensions, do not wear and have quicker response if compared to other protectors, although they do not allow continuous monitoring of motor operating temperature.

Together with their electronic circuits, these thermistors provide full protection against overheating caused by overload, under or overvoltage or frequent reversing operations.

Where thermistor protection is required to provide both alarm and trip operation, it is necessary for each phase of the motor winding to be equipped with two sets of appropriately rated thermistors.

WEG Automation has a product called RPW which is an electronic relay intended specifically to read the PTC signal and operate its output relay. For more information go to the website www.weg.net.

Thermostats

These are silver-contact thermal sensors, normally closed, that operate at certain temperature rise. When their operating temperature decreases, they go back to the original position instantaneously, allowing the silver contact to close again. The thermostats are series-connected with the contactor coil, and can be used either as alarm or trip.

There are also other types of thermal protectors such as PT-1000, KTY and thermocouples. Contact your local WEG office closest to you for more information.

10.2 Protection based on operating current

Overloads are processes that usually make the temperature increase gradually. To solve this problem, the thermal protectors described in item 10.1 are quite suitable. However, the only way to protect motors against short-circuit currents is the application of fuses. This type of protection depends directly on the current and it is highly effective in cases of locked rotor.

WEG Automation supplies fuses in versions D and NH. Go to the site www.weg.net for more information.

Typical Thermostat Control Schematic

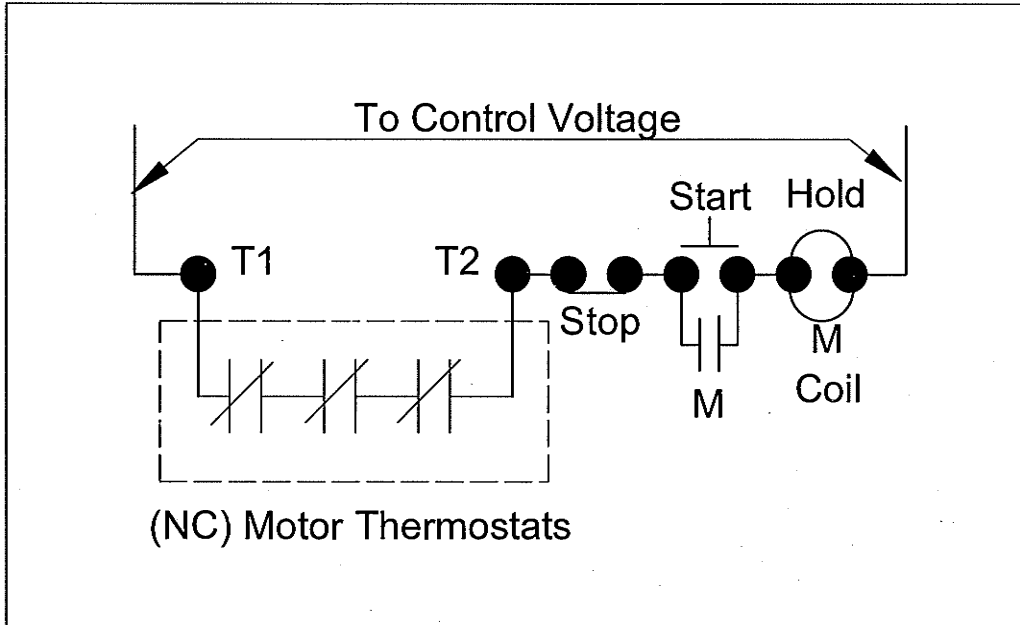



INSTALATION OF SPACE HEATERS IN INDUCTION MOTORS

NORM

WED-002

Page 1 of 2

Source: WEG / TOP - 0137

Rev. 00

06/01/2004

Company: WEM

Origin:

1. OBJECTIVE:

This standard aims at providing specification and installation procedures for “space-heater” installed in WEG motors.

2. WATTAGE AND CONNECTIONS:

FRAMES		TOTAL WATTS (W ± 10%) ³⁾	SPACE HEATER VOLTAGE					
NEMA	IEC		110 ± 22V		220 ± 44V		440 ± 88V	
			TYPE	CONNECTION/Req.	TYPE	CONNECTION/Req.	TYPE	CONNECTION/Req.
	63	8 ¹⁾	20W/m-110V		20W/m-220V		20W/m-440V	
	71							
	80							
143 145	90			Req. = 1,512 Ω		Req. = 6,050Ω		Req.=12,100Ω
100		16 ²⁾	20W/m-110V		20W/m-220V		20W/m-440V	
182 184	112							
				Req. = 756Ω		Req. = 3,025Ω		Req. = 6,050Ω
213 215	132	24	30W/m-110V		30W/m-220V		30W/m-440V	
				Req.= 504Ω		Req. = 2,017Ω		Req. = 8,067Ω
254 256	160	48	30W/m-110V		30W/m-220V		30W/m-440V	
284 286	180							
324 326	200							
				Req. = 252Ω		Req. = 1,008.5Ω		Req = 40,033.5 Ω
364 365	225	79	35W/m-110V		35W/m-220V		35W/m-440V	
404 405	250							
				Req.= 153Ω		Req. = 612Ω		Req.=2,450Ω
444 445	280	158	35W/m-110V		35W/m-220V		35W/m-440V	
447 449								
504/5	315							
5008	315B							
586/7	355							
				Req. = 76.5Ω		Req. = 306Ω		Req. = 1,225Ω

Edited by: Valone Gomes

Note: 1) For voltage of 440V, the total power is = 16W.

2) For voltage of 440V, the total power is = 32W.

3) The total Space Heater Watts is calculated according to: $P = \frac{V^2}{R_{eq}} (W)$

3. SPACE HEATER INSTALLATION

3.1. Space Heater is installed on the stator-winding head (at the opposite side of the leads) before the stator is pressed into the frame. On frame 364 and above, the space heater is installed into the stator-winding head (same side of the leads) after the winding head has been pressed.

3.2. Space Heater is fasten at, minimum, 4 points by nylon cord. For frames 364 and above it is fastened with a polyester jacket.

Notes:

- 1) Space heater installation does not require varnish impregnation.
- 2) Space heater leads are identified by:
 - R1 for the first space heater and
 - R2 for the second space heater (when installed).

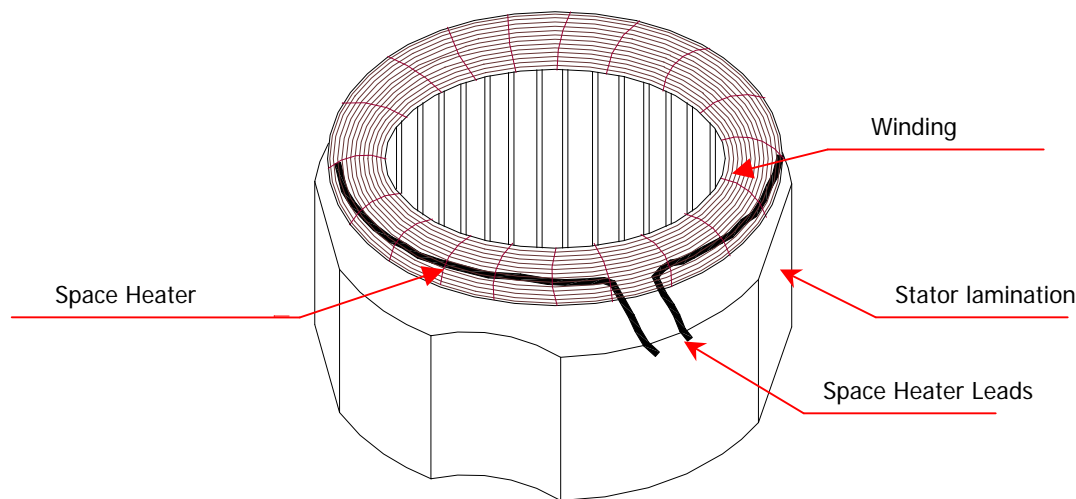

Tab 4

Pump Accessories

Grundplatte
baseplate

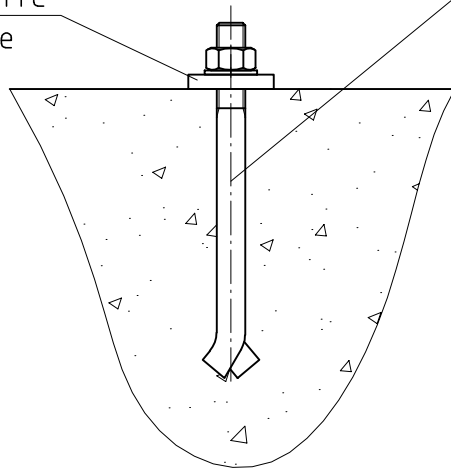

Ankerschraube DIN529-C
foundation bolt

M16x250
oder/or
M20x250

Stück Unit	Norm Standard	Pos./Item	Benennung/Denomination Zeichnungs-Nummer/Drawing-Number	Werkstoff/Material	Bemerkung/Remark	Gewicht Weight kg
---------------	------------------	-----------	--	--------------------	------------------	-------------------------

seepex.com

seepex
GmbH + Co KG
Scharnhölzstraße 344
46240 Bottrop
www.seepex.com

Allgemeintoleranzen für Maße ohne einzelne Toleranzeintragung DIN ISO 2768-mittel	Ausgabe Issue	Änderung Modification	Name Name	Datum Date	Maßstab/Scale 1:10	Werkstoff/Material	Gewicht/Weight
General tolerances for mass without individual tolerance entry DIN ISO 2768-average					Bezeichnung/Denomination Disposition Steinschraube / stone bolt DIN 529-C		
Rauheit für Oberflächenzeichen DIN ISO 1302 Reihe 2	Bearbeitet/Drawn		Name Name	Datum Date	Zeichnungs-Nummer/Drawing-Number 714-839/001A4		
Roughness for surface finish indication DIN ISO 1302 Reihe 2	Geprüft/Checked		her	16.03.2005	EDV-Nr./EDP-No. 685/68608.pdf		
	Normiert/Standard		goe	16.03.2005	Ersatz für/Replacement for:	Ersetzt durch/Replacement by:	
	Gedruckt/Printed						

Urheberrechtsschutz: Diese Zeichnung ist unser Eigentum und uns nach dem Gesetz über Urheberrecht und verwandte Schutzrechte geschützt.
Protection of Copyright: This drawing is our property and is protected acc. to the law referring to copyright and related protective laws.

Information: Siehe auch seepex Information "DRI"

1) Andere Baureihen auf Anfrage

2) Ausgenommen: 5-48: 6 Stck.; 17-48: 8 Stck.

Also refer to seepex information "DRI"

1) Other ranges upon request

2) Except: 5-48: 6 pcs.; 17-48: 8 pcs.

Option Bauteil / Benennung / Ausführung
component / denomination / design

Baugröße / size	
M120	M500
0005-24	025-24
0015-24	025-12
003-12	05-12
003-24	1-6L
006-12	BCSO 05-24
006-24	025-48
012-12	05-48
025-6L	
05-6L.T	
025-12T	

M120	M500	0010	0020	0050	0100	0140	0170	0350	0700	1300	2400
0005-24	025-24	05-24	1-24	2-24	5-24	14-12	10-24	17-24	35-24	70-24	130-24
0015-24	025-12	1-12	2-12	5-12	10-12	14-12	17-12	35-12	70-12	130-12	
003-12	05-12	2-6L	5-6L	10-6L	17-6L	26-6L	26-12	70-6L	100-18	202-6L	
003-24	1-6L	01-48		15-6LT	30-6LT	40-6LT	35-6L	100-6L	130-6L	202-6L	
006-12	BCSO 05-24						95-6LT	110-6LT	300-6L		
006-24	025-48				10-24R		17-24R	35-24R	70-24R	130-24R	
012-12	05-48			8-12T	15-12T		30-12T	55-12T	110-12T	200-12T	
025-6L							52-6L	52-12	200-6L	70-18	
05-6L.T							75-6LT			130-18	
025-12T					5-12V		10-12V	17-12V	35-12V	70-12V	
								5-48	10-48	17-48	
							5-48	10-48	17-48	35-48	

Fundamentschrauben
foundation bolts

Steinschraube nach DIN 529, Ausf. C inkl. Scheibe und Mutter Stone bolt acc. to DIN 529, design C incl. washer and nut	Grundplatte mit Laschen base plate with side feet	1.0037 verz. (St 37-2 verz.)	4 x M16 x 250	4 x M20 x 250	6 x M20 x 250	2)	4 x M20 x 250	6 x M20 x 250	2)	---
		1.0037 galv. (St 37-2 / steel galvanized)	4 x M16 x 250	4 x M20 x 250	6 x M20 x 250	2)	4 x M20 x 250	6 x M20 x 250	2)	---
Verbundanker inkl. Patrone, Ankerstange, Scheibe und Mutter chemical anchor incl. capsule, anchor stud, washer and nut	Grundplatte ohne Laschen base plate without side feet	1.0037 verz. (St 37-2 verz.)	4 x M16 x 250	4 x M20 x 250	6 x M20 x 250	2)	4 x M20 x 250	6 x M20 x 250	2)	---
		1.0037 galv. (St 37-2 / steel galvanized)	4 x M16 x 250	4 x M20 x 250	6 x M20 x 250	2)	4 x M20 x 250	6 x M20 x 250	2)	---
Baureihe / range BN Baugruppe / group CS 1)	Grundplatte mit Laschen base plate with side feet	1.0037 verz. (St 37-2 verz.)	4 x M16 x 165	4 x M20 x 220	6 x M20 x 220	2)	4 x M20 x 220	6 x M20 x 220	2)	---
		1.0037 galv. (St 37-2 / steel galvanized)	4 x M16 x 165	4 x M20 x 220	6 x M20 x 220	2)	4 x M20 x 220	6 x M20 x 220	2)	---
Baureihe / range BN Baugruppe / group CS 1)	Grundplatte ohne Laschen base plate without side feet	1.4571	4 x M16 x 165	---	---	---	---	---	---	---
		1.0037 verz. (St 37-2 verz.)	4 x M16 x 250	4 x M20 x 300	6 x M20 x 300	2)	4 x M20 x 300	6 x M20 x 300	2)	---
		1.4571	---	---	---	---	---	---	---	---
		1.0037 galv. (St 37-2 / steel galvanized)	---	---	---	---	---	---	---	---

Pressure Switch/Gauge Details

Project: Weaver Constr-Englewood, CO-Ambiente H2O-Harold D. Thompson Water Reclamation Facility-PO#: 9103

Digested Sludge	BN 52-6L	832027-028	DSP-1 & 2
------------------------	-----------------	-------------------	----------------------

Mounting: (Check One)

Isolation Ring: **X**
Diaphragm Seal: **None**
Manufacturer: **Onyx PSW 5"**

Pressure Gauge Detail:

1. Manufacturer: **Ashcroft**
2. Model No.: **1008**
3. Liquid Fill? **No**
4. Face Diameter: **4"**
5. Range: **0 - 100 PSI**

Pressure Switch Detail:

1. Manufacturer: **Ashcroft**
2. Model No.: **B4 24 B**
3. Enclosure: **NEMA 4X**
4. Pressure Range: **0 – 100 PSI**
5. Manual Reset? **No**
6. SPDT or DPDT? **SPDT**

Pressure Switch/Gauge Details

Project: Weaver Constr-Englewood, CO-Ambiente H2O-Harold D. Thompson Water Reclamation Facility-PO#: 9103

Scum	BN 35-6L	832029-030	SCP-1 & 2
------	----------	------------	-----------

Mounting: (Check One)

Isolation Ring: X
Diaphragm Seal: None
Manufacturer: Onyx PSW 4"

Pressure Gauge Detail:

1. Manufacturer: Ashcroft
2. Model No.: 1008
3. Liquid Fill? No
4. Face Diameter: 4"
5. Range: 0 - 100 PSI

Pressure Switch Detail:

1. Manufacturer: Ashcroft
2. Model No.: B4 24 B
3. Enclosure: NEMA 4X
4. Pressure Range: 0 – 100 PSI
5. Manual Reset? No
6. SPDT or DPDT? SPDT

ONYXX VALVE

Pressure Isolator Ring

New Patented Design Assures Accuracy
and Maintenance-Free Operation
Patent #5,708,201



The Onyx Isolator Ring

Outperforms Conventional Isolator Rings and Standard Diaphragm Seals

Obtaining accurate pressure readings on pipelines is difficult because slurries, abrasives, and solids clog gauges, switches, and transmitters. Standard diaphragm seals—drilled or welded at a point on the pipeline—provide a temporary solution, but are vulnerable to plugging and stop working when slurry solidifies in the seal chamber. Conventional isolator rings consist of a rubber “inner tube” captured in a steel ring. The assembly is installed between flanges in the process pipe. Clear instrument fluid behind the rubber membrane transmits pressure to the gauge. The inside diameter of the ring assembly matches the adjacent pipe so the ring is continually cleaned by the motion of the process fluid. A common problem with this type of isolator ring is that any air inside the instrument will compress when pressurized.

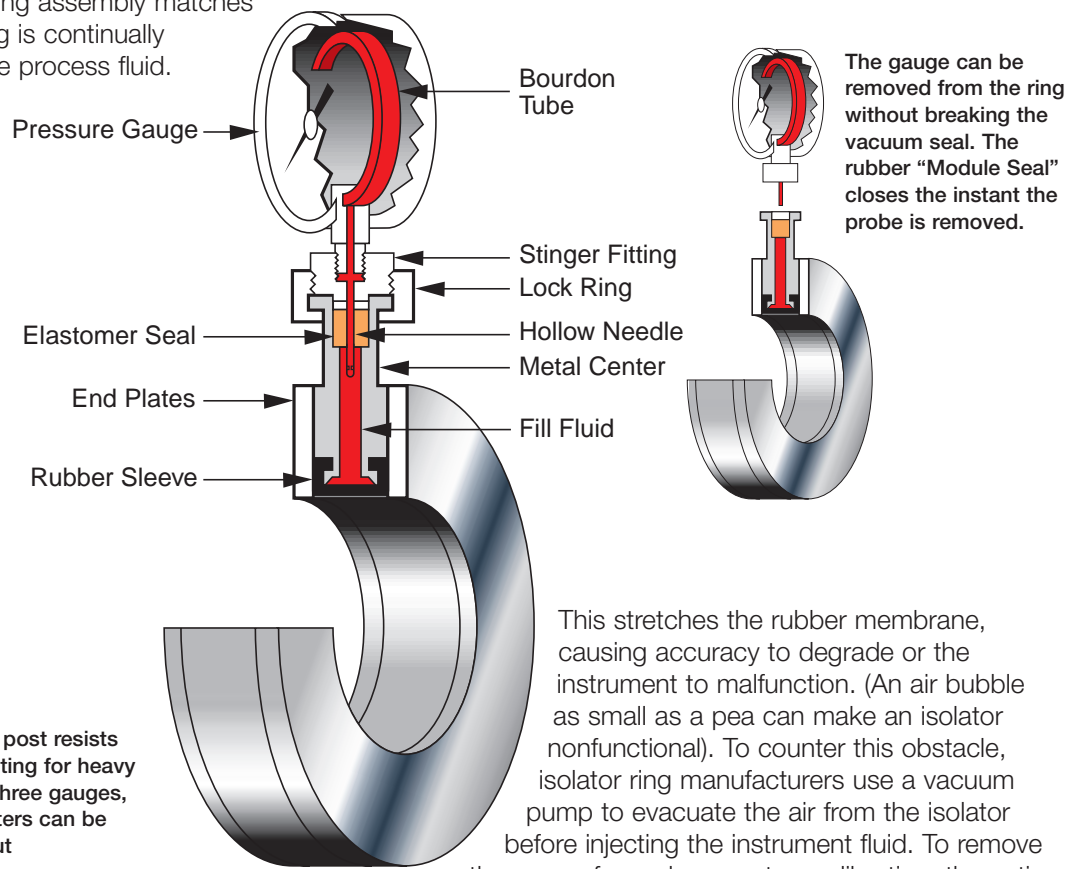
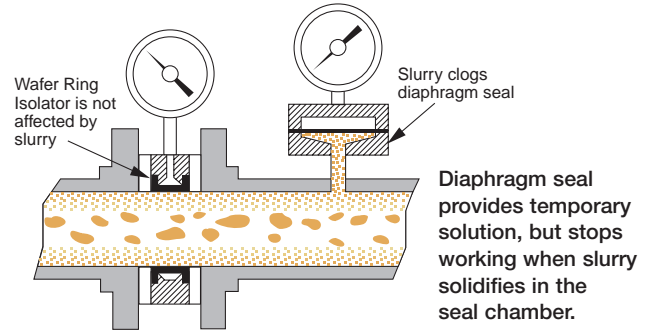

Robust 0.87” diameter mounting post resists breakage. Provides sturdy mounting for heavy gauges and instruments. Up to three gauges, pressure switches, and transmitters can be combined on one isolator without additional support.

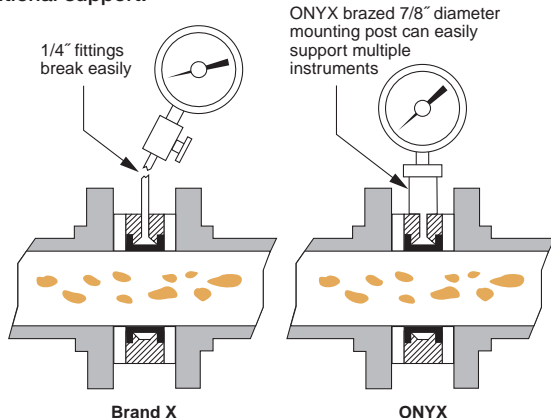

This stretches the rubber membrane, causing accuracy to degrade or the instrument to malfunction. (An air bubble as small as a pea can make an isolator nonfunctional). To counter this obstacle, isolator ring manufacturers use a vacuum pump to evacuate the air from the isolator before injecting the instrument fluid. To remove the gauge for replacement or calibration, the entire ring and gauge assembly must be removed from the process pipe and the gauge and ring have to be drained, evacuated, and refilled. The customer for this type of isolator ring will experience much downtime and expense. Some manufacturers try to circumvent this problem by adding a valve to the ring assembly. This holds the fluid in the ring, but attempting to fill the gauge by turning it upside down and pouring fluid into it traps an air pocket at the tip of the Bourdon tube. Also, attempting to remount the gauge by covering the connection with your finger while turning it upright and screwing it into the isolator is rarely successful.

Smart Box

The Preengineered Pump Protection Package

Features

- Over Pressure Protection
- Run Dry Protection
- Functions as a Local Control Station
- Simple Two-Button Operation
- Panel Lights Show Pump Status
- Microprocessor Based
- Preprogrammed Ready to Run
- Corrosion Resistant Fiberglass NEMA-4X Enclosure for Indoor or Outdoor Service
- Easy Interface with Fixed Speed or Variable Speed Pumps
- Easy Interface to Remote Controls
- Broken Wire Detection
- Safe 24 Volt Signal Wiring

Applications

The Onyx Smart Box protects pumps from damage and downtime caused by run dry or over pressure conditions. It can be combined with our Isolator Ring for dependable operation with viscous, abrasive, corrosive, or volatile fluids or suspensions and slurries.



Onyx Smart Box ensures that progressing cavity pumps operate within design parameters.

Options:

- Audible Alarm
- Explosion Proof Enclosure
- Seal Flush Kit
- Fused Disconnect
- Circuit Breaker
- Key Lock on STOP Button
- Motor Starter
- VFD
- Level Control Package

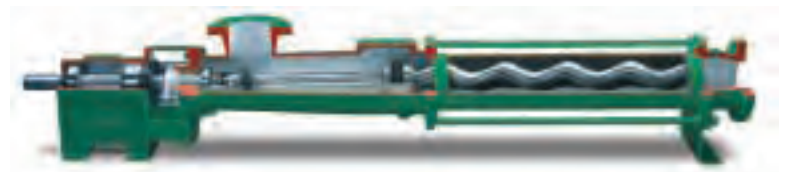

The Onyx Isolator Ring:

The Solid Solution for Solving Your Pressure Measurement Problems

The Onyx Isolator Ring provides a practical, cost-effective method for obtaining accurate pressure measurements on slurries, abrasives, and hard-to-handle materials. The Onyx Isolator Ring's new patented design solves the problems associated with isolator

rings on the market today. The Onyx Isolator Ring is vacuum-filled at the factory with high-viscosity silicone fluid; then permanently sealed with Onyx's Revolutionary "Module-Seal". With the Onyx Isolator Ring, there is no fill port anywhere on the assembly: gauges, switches, and transmitters are supplied separately, are prefilled with Onyx's special fitting attached. You have the option of selecting any combination of isolator ring and gauge and simply snapping them together. With the Onyx Isolator Ring, you are guaranteed hassle-free operation and added protection for your sensitive indication instrumentation.

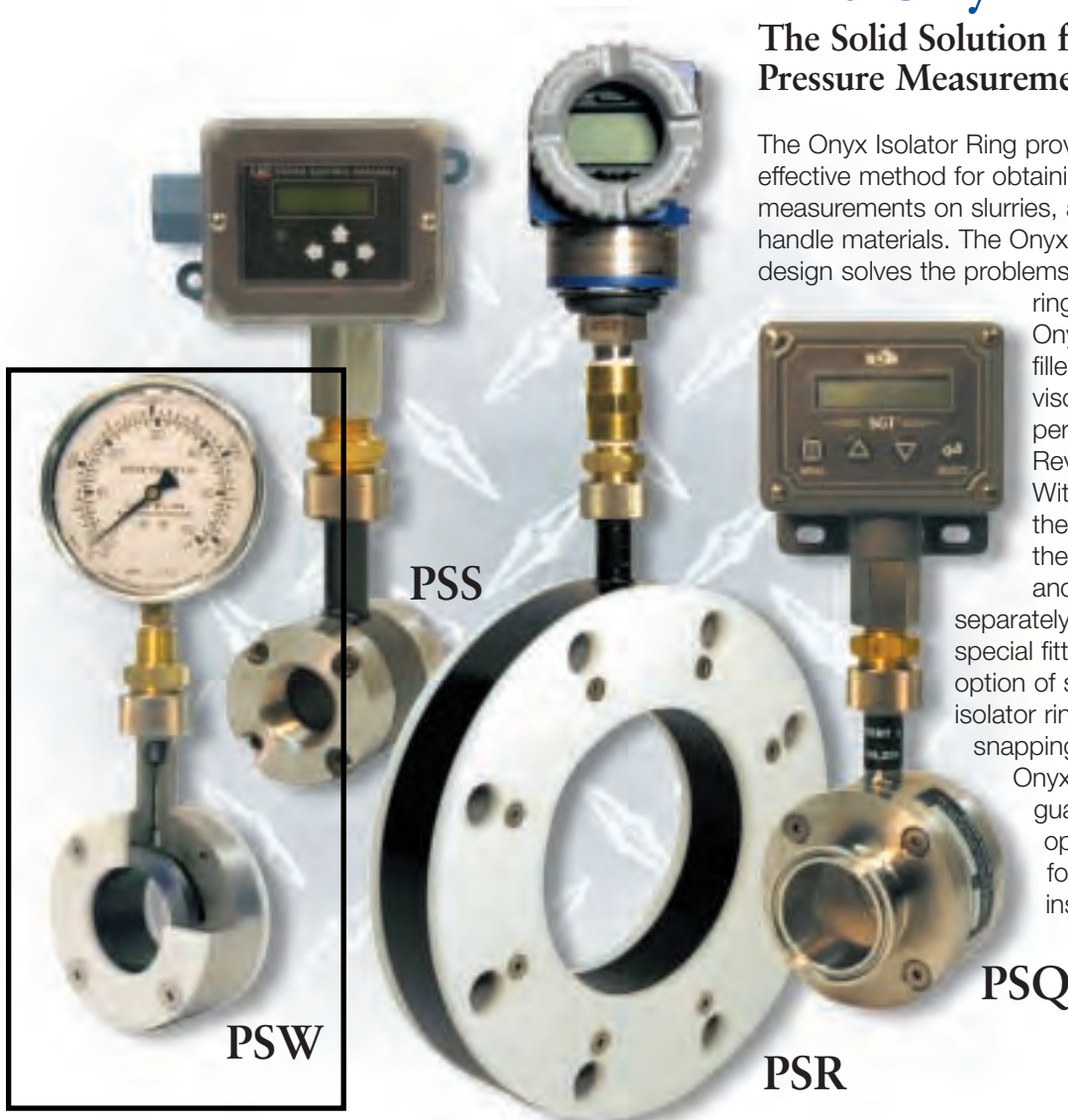

Practical Applications of The Onyx Isolator Ring

The Onyx Isolator Ring can be used in a variety of industries such as chemical, food & beverage, mining, pulp & paper, and wastewater treatment. Typical applications include:

- Pressure measurement of slurries, corrosives, and difficult fluids
- Tank level indication
- Monitoring pressure on long distance pipelines to detect line breakage
- Monitoring pressure drop across a filter or pump using two sensors with a differential pressure switch
- Measuring the output pressure of a pump
- Sending a signal to stop a pump or open a by-pass valve

Proven Benefits of The Onyx Isolator Ring

- Gauges can be removed or replaced without interrupting process
- Gauges can be replaced without vacuum filling
- No tools required to change pressure instrument (simply remove and replace by turning the lock ring)
- No snubber required (needle functions as built-in snubber)
- Improved safety (process liquid cannot escape if gauge is removed, even if process pipe is under pressure)
- High accuracy (because air can never get into the system)
- No isolation valve required
- Gauges can be rotated by hand to face any direction
- Isolation rings and gauges can be stocked separately (combine as needed on the spot)

Technical Specifications of The Onyx Isolator Ring

Center Section:	<ul style="list-style-type: none"> • Carbon Steel* • 316 Stainless Steel • Carpenter-20 	
End Plates:	<ul style="list-style-type: none"> • Acetal • 316 Stainless Steel • Teflon® 	<ul style="list-style-type: none"> • Kynar® • Titanium • Carpenter-20
Elastomer:	<ul style="list-style-type: none"> • Neoprene • Nitrile (Buna-N) • EPDM (Nordel®) • Fluoroelastomer (Viton®) 	<ul style="list-style-type: none"> -20°F → 220°F -20°F → 180°F -20°F → 300°F
	<ul style="list-style-type: none"> (Available with optional Teflon coatings) • Chlorosulfonated Polyethylene (Hypalon®) 	<ul style="list-style-type: none"> -20°F → 375°F -20°F → 250°F
Fill Fluid:	<ul style="list-style-type: none"> • Silicone Fluid • Food Grade Silicone (Optional) 	<ul style="list-style-type: none"> -40°F → 400°F -20°F → 400°F
Pressure Range:	Vacuum to +1,000 psi	The Onyx Isolator has been tested by an independent lab to 1,500 psi

*Coatings available. Consult factory.

Sizes, dimensions, and materials may vary depending on series.

SIZE	ØA	B
1	2.50	1.87
1-1/2	3.25	1.87
2	4.00	1.87
2-1/2	4.75	1.87
3	5.25	1.87
4	6.75	2.12
5	7.62	2.25
6	8.62	2.25
8	10.87	2.25
10	13.25	2.81
12	16.00	3.12
14	17.62	3.12
16	20.12	3.12
18	21.50	3.12
20	23.75	3.12
24	32.00	3.12

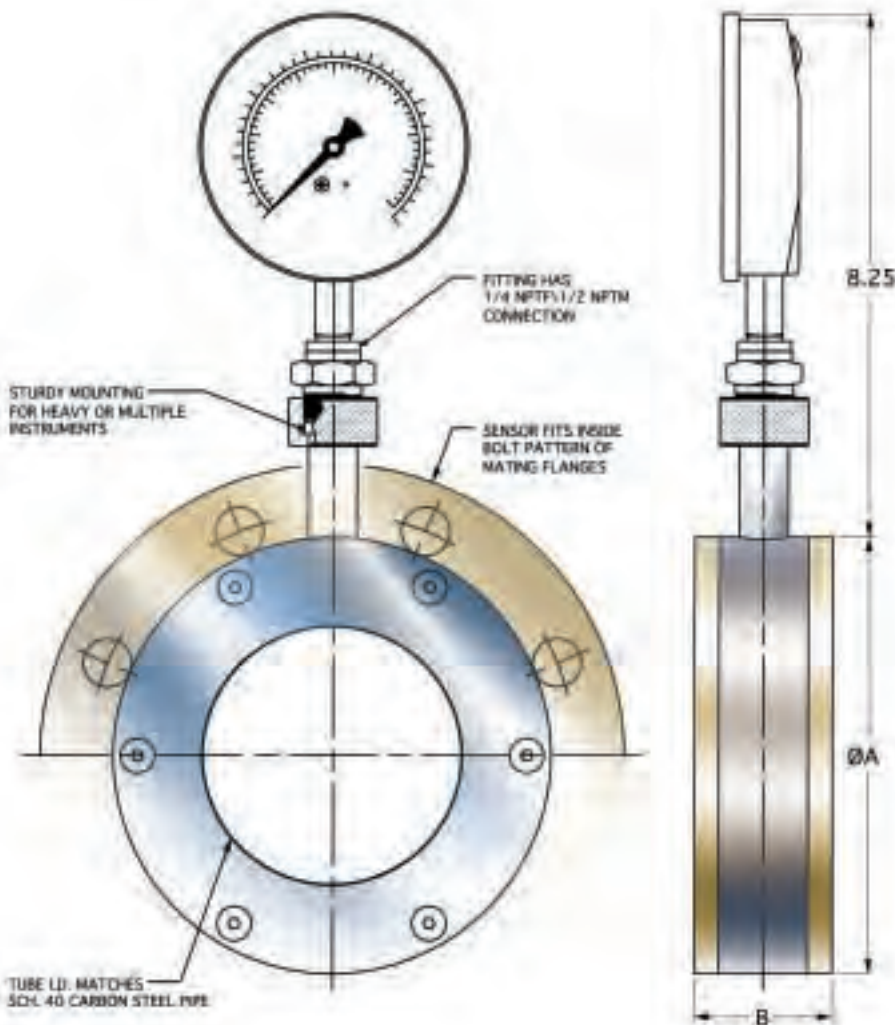

- Center Material:**
- Carbon Steel
 - 316 Stainless Steel
 - Carpenter-20 Stainless Steel
- End Plate Material:**
- Acetal
 - 316 Stainless Steel
 - Carpenter-20 Stainless Steel
 - Teflon
- Sleeve Elastomer:**
-
- Module Seal Stinger Fitting Material:**
- Brass (Std)
 - 316 Stainless Steel
- Pipe Fittings Material (1/2 NPT Std):**
- Carbon Steel
 - 316 S.S.
- Fill Fluid:**
- Silicone (Std) (-40°F TO 400°F)
 - Vegetable Oil (FDA)
- Other _____
- Pressure Rating:** 1,000 PSI
All dimensions are in inches.

Series PSW

Quick Start Instructions

How to Turn the Gauge to Face a New Direction

Onyx Isolator Rings are usually assembled with the gauge axis parallel to the axis of the process pipe. This allows for the most compact configuration for shipping purposes. However, if you wish, it is possible to rotate the gauge to face any desired direction without compromising the integrity of the vacuum fill.

DO NOT LOOSEN THE CONNECTION BETWEEN THE STINGER FITTING AND THE GAUGE. Failure to observe this precaution could cause the fill fluid to leak, compromising the integrity of the vacuum fill.

To rotate the gauge, loosen **the knurled lock ring** on the module seal. This can usually be loosened by hand, but if it is too tight, you can use channel lock pliers.

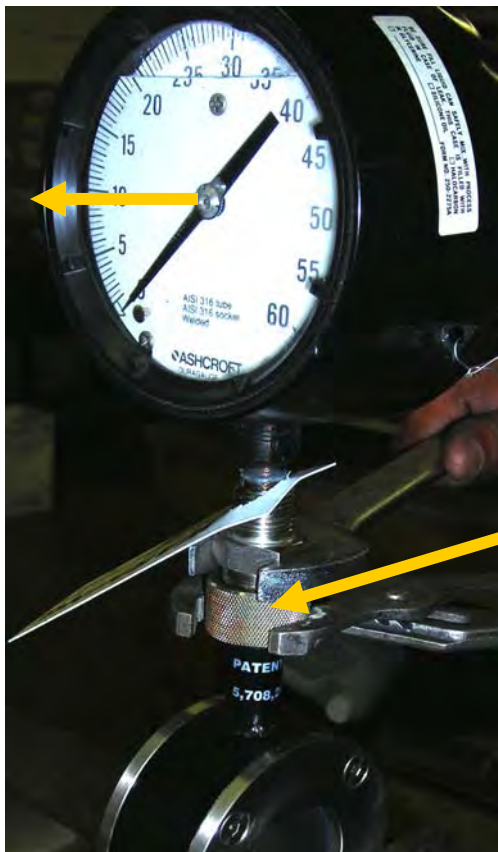
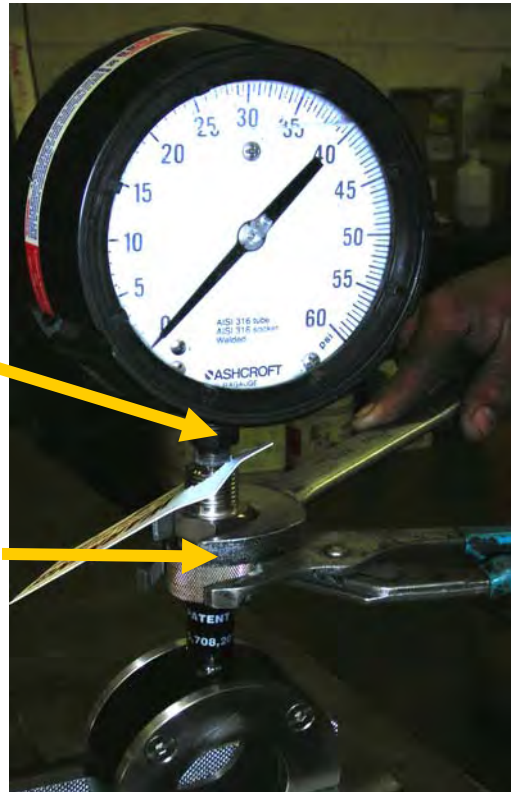

Use an open-end wrench to keep the stinger fitting from rotating, and use the channel lock pliers to loosen the knurled ring as shown in the picture.

Rotate the knurled ring clockwise as viewed from above to loosen it. You just have to break the lock ring free, 1/8 turn is more than adequate. Don't remove it completely. The gauge will now rotate freely to face any desired direction.

Turn the gauge as desired, and use the channel lock pliers to re-tighten the lock ring.

Changing Instruments on an Onyx Isolator Ring

Start by making sure that you have the new gauge (or other pressure instrument) on hand, and that the new instrument is the correct range.

Make sure the new instrument enclosure is appropriate for the environment. A gauge for outdoor service should be sealed construction; an electrical device such as a switch or transmitter must have an explosion proof enclosure if the area is classified as a hazardous environment.

The only tools you might need are a pair of channel lock pliers and a 1/4" Allen key.

Before removing the old gauge, **reduce the line pressure as close to zero as practical.** Turn off the pump if there is one connected to the process line.

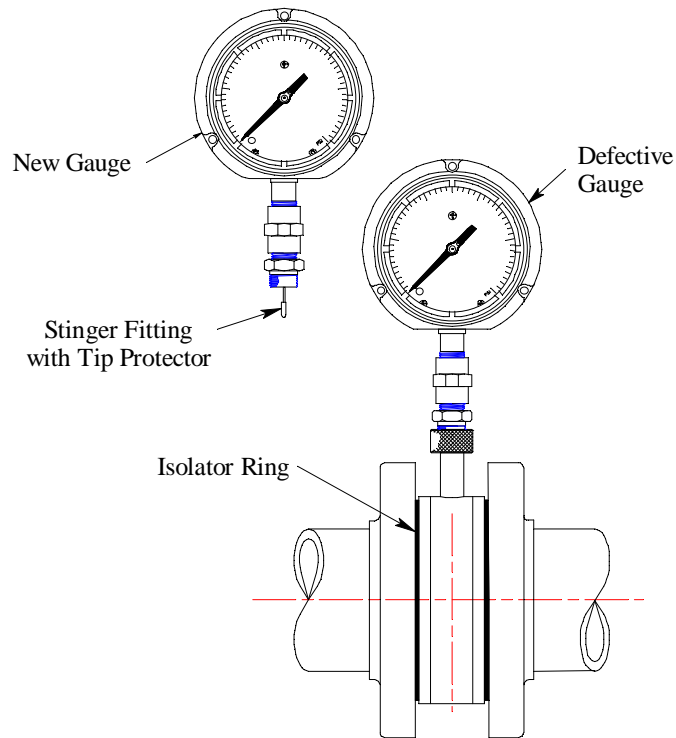

CAUTION: This assembly is vacuum filled with instrument oil. Do NOT loosen or separate any of the pipefittings, or the instrument will not function properly and the warranty is void.

After the line pressure is down, start by loosening the knurled lock ring on the Module Seal post (see diagram at the right).

If you can't loosen the ring by hand, a pair of channel lock pliers should persuade it to cooperate.

When the knurled lock ring is completely free from the brass stinger, pull straight up on the gauge with a firm, gentle pressure until the stinger needle pulls free from rubber diaphragm in the Module Seal.

At this point, check to see if there is any weeping in the Module Seal. If any oil seeps out, insert an Allen key into the top of the Module Seal post and snug down (1/8 turn should do it) on the diaphragm.

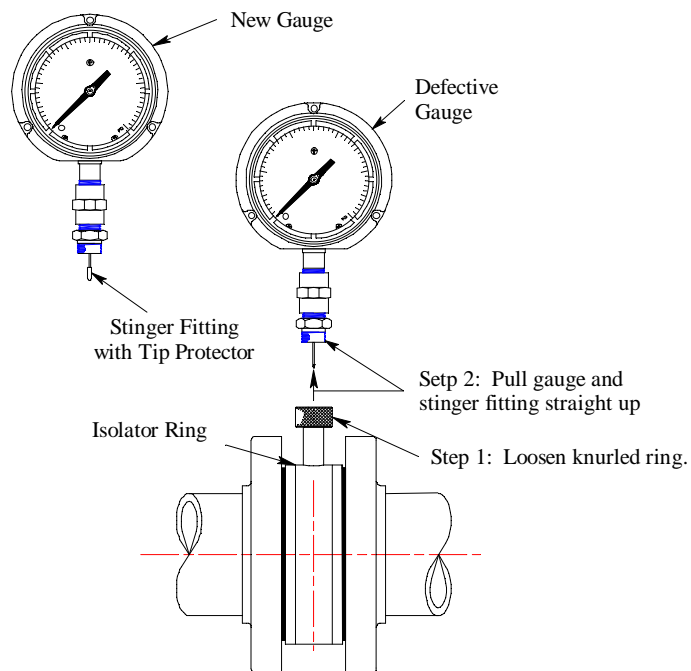

On the new gauge, remove the rubber tip protector. (Don't tarry: You have 3 to 4 minutes until the oil drips out.)

You can replace the tip protector onto the old gauge to keep it from dribbling oil.

Take the new gauge, position the stinger needle right over the rubber diaphragm in the Module Seal and applying firm steady pressure insert the needle through the original hole into the Module Seal until the bottom of the brass stinger fitting hits home.

Don't force it. If it doesn't go in readily, use an Allen key and loosen the module seal about 1/8 turn and try again.

Replace the knurled lock ring and thread it back onto the new stinger fitting. Turn the gauge into any position convenient for viewing. Use a channel lock to snug it up so it doesn't vibrate loose.

The "Pressure Instrument" can be a complete assembly consisting of a gauge and switch, or any other combination of pressure instruments. In this case, the same procedure applies.

You extract and replace the entire manifold assembly *as one piece*.

CAUTION: This assembly is vacuum filled with instrument oil. Do NOT loosen or separate any pipe fittings, or the instrument will not function properly and the warranty is void.

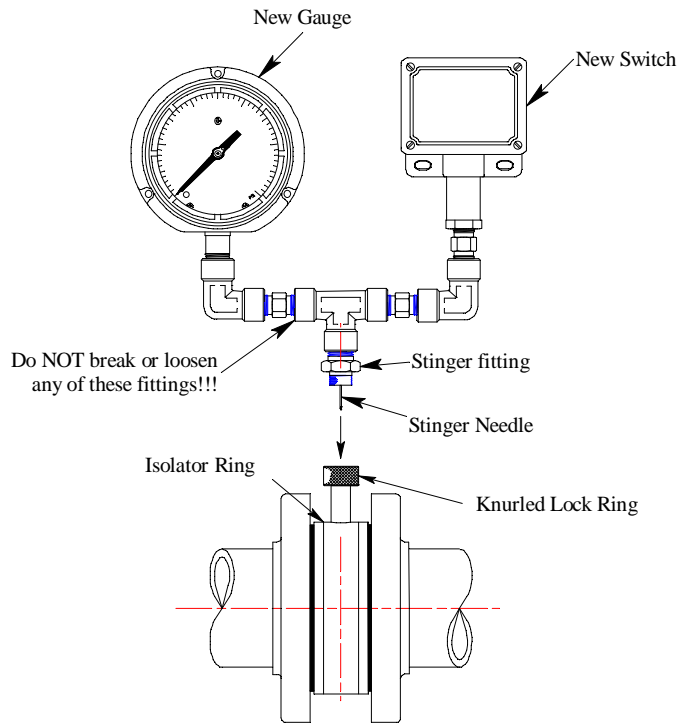
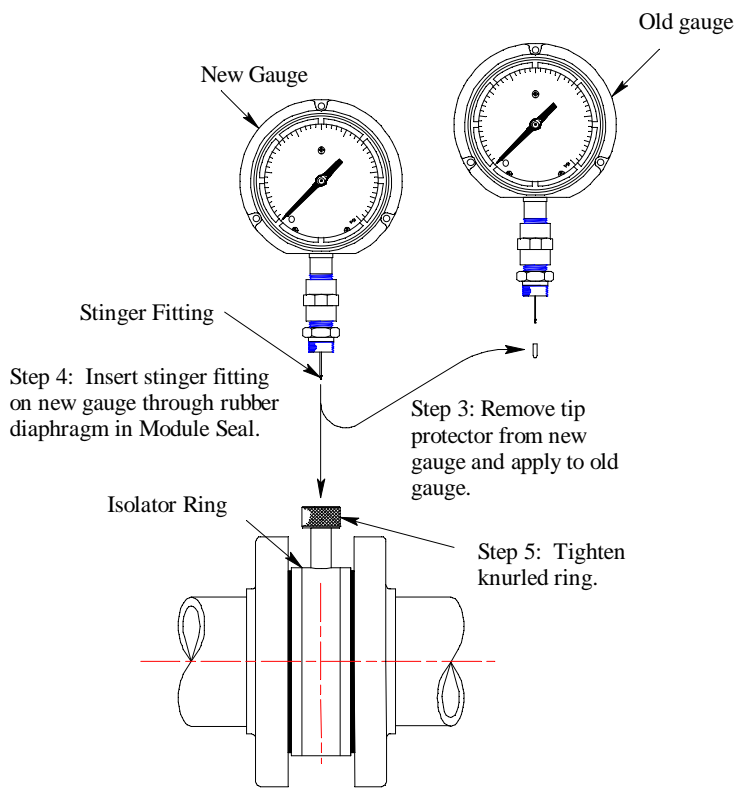

If you notice fill fluid weeping from the module seal:

Occasionally the module seal will weep a few drops of the fill fluid. If this happens, temporarily remove the gauge assembly from the isolator ring. Insert a 1/4" Allen hex key into the module seal as shown in the picture on the right and turn 1/8 of a turn clockwise to tighten the seal. Then replace the gauge.



If the module seal is too tight to insert the stinger fitting, loosen the adjustment a little bit by rotating the hex key anti-clockwise. Just a few degrees of rotation with the hex key should be sufficient to reinsert the stinger.

Questions?

Call Onyx Valve Co.

P: 856-829-2888

www.onyxvalve.com



Stainless Steel Case Gauge Type 1008A/AL, 63mm and 100mm ASME B 40.1 Grade B (±3-2-3% of span)

- 63mm (2½") and 100mm (4") case sizes
- Soldered brass socket and bronze tube design
- Corrosion-resistant stainless steel case/ring
- Dry, field-fillable or liquid-filled versions
- Patented PowerFlex™ movement
- True Zero™ indication, a unique safety feature
- Two-year warranty on liquid-filled gauges

Ashcroft® Type 1008A gauges are synonymous with durability, flexibility and exceptional quality. The Type 1008A gauge enclosure is sealed to provide maximum protection in adverse environmental conditions. Both 63mm and 100mm Type 1008A gauges are available dry, field-fillable, glycerin filled or silicone filled. Accessory kits are available for panel mounting, front flange mounting or retrofit mounting back connection gauges. The patented PowerFlex movement provides a higher level of shock, vibration and pulsation resistance than conventional movement gauges.

The True Zero feature helps to assure a quality process and reduces manufacturing and inspection costs.



FlutterGuard™ is available for dry gauges to eliminate pointer flutter and extend gauge life.

GAUGE SPECIFICATIONS

Type no.:	1008A/AL
Accuracy:	ASME B 40.1 Grade B (±3-2-3% of span)
Size:	63mm (2½"), 100mm (4")
Case:	304 stainless steel, dry (1008A), or liquid filled (1008AL)
Fill Fluid:	Glycerin
Ring:	304 stainless steel, crimped
Window:	Polycarbonate
Dial:	Black figures on white background, aluminum
Pointer:	Black, aluminum
Bourdon Tube:	"C" shaped bronze (vac.-600 psi and compound) Helical bronze (1000 psi-6000 psi) Helical stainless steel (10,000 psi-15,000 psi)

Movement:	Patented PowerFlex with polyester segment
Socket:	Brass, with O-ring case seal
Restrictor:	Brass throttle plug, 0.013" orifice in all ranges (except vacuum and 15# psi ranges)
Connection:	¼ NPT lower and back
Ranges:	Vac. thru 15,000 psi and compound. Equivalent metric ranges available
Operating Temperature:	Dry gauge: -40°F to 150°F Glycerine filled: 20°F to 150°F

GAUGE OPTIONS

Case:	Sealed case, field-fillable (LJ) Silicone filled (GV)
Mounting Hardware:	U-clamp (UC), front flange (FF), retrofit flange (RF)
Socket:	Throttle plugs, 0.007", 0.020", 0.063"
Connections:	JIS, DIN and other connections on application
Others:	Customized dials Nonstandard ranges FlutterGuard (SF) Special calibration on application Clean for oxygen service – dry gauges only Metric and SAE connection

TO ORDER THIS TYPE 1008A/AL GAUGE:

Select:	63	1008	A	L	02B	XUC	1000#
1. Dial Size: 63mm or 100mm _____							
2. Case Type: 1008 _____							
3. Socket Material: Brass _____							
4. Liquid Filled (Glycerin), leave blank if dry _____							
5. Connection Size: ¼ NPT _____							
6. Connection Location: Lower (L), Back (B) _____							
7. Optional Features: XUC = Panel Mounting Kit _____							
8. Range: 1000 psi _____							

Consult factory for guidance in product selection
Phone (203) 385-0217, Fax (203) 385-0602 or
visit our web site at www.ashcroft.com



Pressure and Differential Pressure Switches, Watertight Enclosure, Type 400, B-Series

This general purpose Ashcroft® switch series is ideal for use in virtually all Industrial and OEM applications.

- Watertight NEMA 4X enclosure, IP66
- Choice of switch elements for all applications, including hermetically sealed
- Wide choice of wetted materials, including all-welded Monel or stainless steel
- Fixed or limited adjustable deadband
- Approved for UL, CSA and FM® ratings

- Choice of actuators, including designs for fire-safe and NACE applications⁽⁹⁾
- Readily available
- Standard pressure connection materials:

Pressure psi ranges
- 316L stainless steel

Differential psid ranges
- Nickel-plated brass⁽⁹⁾

Pressure and differential inches of water ranges
- Epoxy coated carbon steel



1 - ENCLOSURE

B4 - Pressure switch, type 400, watertight enclosure meets NEMA 3, 4, 4X and 13, IP66 requirements

D4 - Differential pressure switch, type 400, watertight enclosure meets NEMA 3, 4, 4X and 13, IP66 requirements

2 - SWITCH ELEMENTS

Order Code	Description/Maximum Electrical Ratings	UL/CSA Listed SPDT
20 ⁽⁴⁾	Narrow deadband	15A, 125/250 Vac
21 ⁽⁹⁾	Ammonia service	5A, 125/250 Vac
22 ⁽³⁾	Hermetically sealed switch, narrow deadband	5A, 125/250 Vac
23	Heavy duty ac	20A, 125/250 Vac
24 ⁽¹⁾	General purpose	15A, 125/250/480 Vac 1/2A, 125 Vdc 1/4A, 250 Vdc
25	Heavy duty dc	10A, 125/ Vac or dc 1/8HP 125/ Vac or dc
26 ⁽⁴⁾	Sealed environment proof	15A, 125/250 Vac
27	High temp. 300°F	15A, 125/250 Vac
28	Manual reset trip on increasing	15A, 125/250 Vac
29	Manual reset trip on decreasing	15A, 125/250 Vac
31	Low level (gold) contacts	1A, 125/250 Vac
32	Hermetically sealed switch, general purpose	11A, 125/250 Vac 5A, 30 Vdc
50	Variable deadband	15A, 125/250 Vac
UL/CSA Listed Dual SPDT⁽²⁾		
61 ⁽⁴⁾	Dual narrow deadband	15A, 125/250 Vac
62 ⁽⁴⁾	Dual narrow environment proof	15A, 125/250 Vac
63	Dual high temp. 300°F	15A, 125/250 Vac
64	Dual general purpose	15A, 125/250/480 Vac 1/2A, 125 Vdc 1/4A, 250 Vdc
65	Dual ammonia service	5A, 125/250/480

3 - ACTUATOR SEAL⁽⁷⁾

Code & Material	Process Temp. ⁽⁶⁾ °F	Range			
		Vac in. H ₂ O	0-600 psi	1000 psi	2000-3000 psi
B-Buna N	0 to 150	●	●	●	●
V-Viton	20 to 300	●	●	●	
T-Teflon	0 to 150	●	●	●	●
S-SS ⁽⁵⁾⁽¹⁰⁾	0 to 300		●	●	
P-Monel ⁽⁵⁾	0 to 300		●	●	

4 - OPTIONS

(See pages 229-230)

5 - STANDARD PRESSURE RANGES

(See page 226)

NOTES:

- Standard switch.
- Dual switches are 2 SPDT snap-action switches not independently adjustable.
- Estimated dc rating, 2.5A, 28 Vdc (not UL listed).
- Estimated dc rating, .4A, 120 Vdc (not UL listed).
- Available on pressure only.
- Ambient operating temperature limits -20 to 150°F, all styles. Setpoint shift of ±1% of range per 50°F is normal. Switch calibrated at 70°F reference.
- Items are wetted by process fluid.
- Refer to Option Table.
- Order Option XUD, stainless steel process connection.
- On differential switches, stainless steel is available in 15, 30, 60 and 90 psid ranges only. Includes Teflon O-ring and 316 SS connection.

TO ORDER THIS B-SERIES PRESSURE SWITCH:

Select: **B4 20 B XPK 600 psi**

- Enclosure: _____
- Switch Element: _____
- Actuator Seal: _____
- Options (See pages 229-230): _____
- Pressure Range (See page 226): _____

HERMETICALLY SEALED SWITCH

We recommend hermetically sealed switch elements for improved reliability. The hermetically sealed switch provides uncompromising contact protection in harsh or corrosive environments. The Ashcroft 400 Series is also approved for installation in Division II hazardous areas when supplied with hermetically sealed contacts.

Features:

- UL-recognized component, guide WSQ2, File E85076
- All-stainless steel welded construction



Consult factory for guidance in product selection
Phone (203) 385-0217, Fax (203) 385-0602 or
visit our web site at www.ashcroft.com





Series **230**

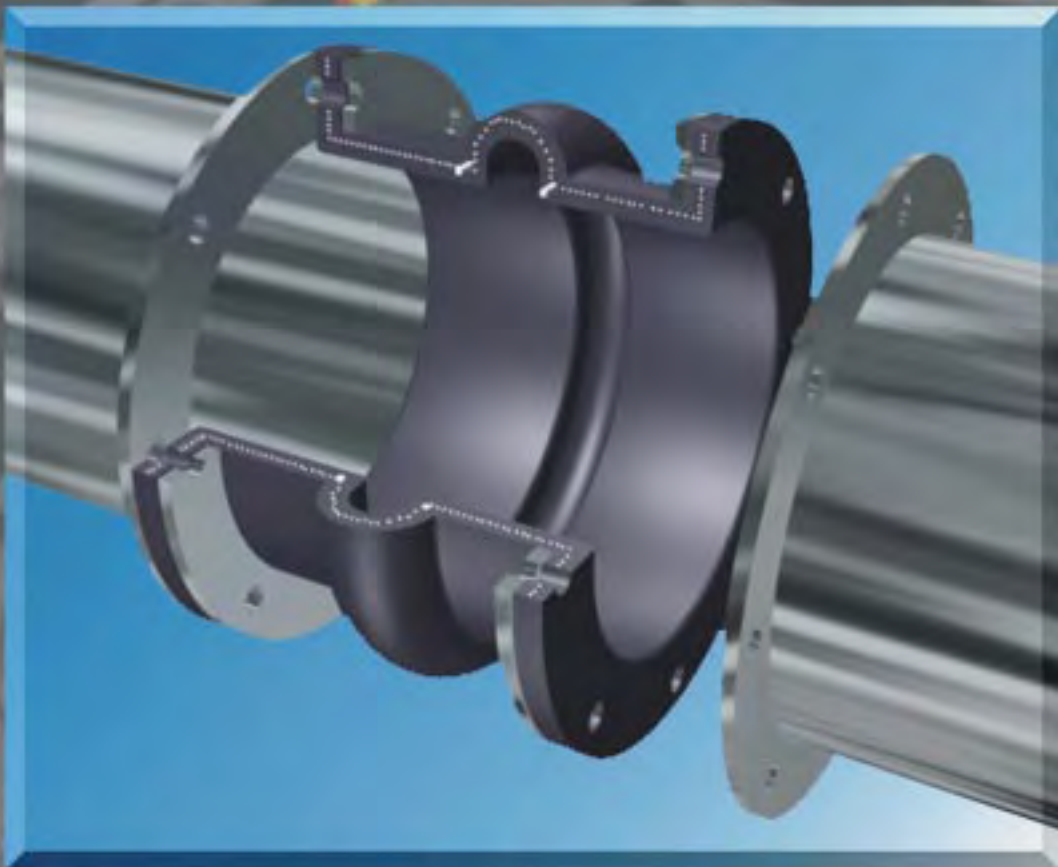

The Expansion Joint People

PROCO

SERIES

230/220

spool type wide arch
rubber expansion joints



PROCO Series 230, Styles 231, 232, & 233 Non-Metallic Expansion Joints are designed for tough, demanding industrial applications, as found in: **Chemical/Petrochemical Plants, Industrial Process Piping Systems, Marine Services, Power Generation Plants, Pulp/Paper Plants, Steel Mills, Water/Wastewater and Pollution Control Systems.** Installed next to mechanical equipment or between the anchor points of a piping system, specify the PROCO Series 230 to: (1) Absorb Pipe Movement/Stress, (2) Reduce System Noise, (3) Isolate Mechanical Vibration, (4) Compensate Alignment/Offset, (5) Eliminate Electrolysis, (6) Protect Against Start-Up Surge Forces. Our history in the manufacture of expansion joints dates back to 1930. When you need an engineered rubber expansion joint solution to a piping problem, call PROCO!

Series 230 Replaces Series 220. The new and improved PROCO Series 230 replaces the PROCO Series 220 rubber expansion joints. (Series 220 products will be available only in short neutral lengths.) This new hand-built product has been completely re-engineered to provide improved strength, flexibility, movement and spring rate capabilities. Manufactured utilizing tire industry technology, the Series 230 combines woven nylon fabric and nylon tire cord into a fabric matrix bonded with elastomer and reinforced with wire to create a product with greater operating performance. The nomenclature for the new PROCO Series 230 is as follows:

- Single Arch Series 230, **Style 231**
- Double Arch Series 230, **Style 232**
- Triple Arch Series 230, **Style 233**

Greater Movements With A Lower/Wider Arch Profile. The movements for the PROCO Series 230 exceed the specification of the Fluid Sealing Association's Rubber Expansion Joint Division Technical Handbook (Sixth Edition), Table V. Due to a new and improved lower, wider profile arch, more axial compression and axial extension coupled with lateral misalignment, angular and torsional movements can be obtained without increasing the face-to-face requirements. Installation of the Series 230 in a piping system will negate the need for long and expensive multi-arch products. For greater movements based on re-engineering and new product construction, specify the PROCO Series 230.

Less Turbulence Or Material Entrapment. The PROCO 230 Series molded integral flange joins the body at a true 90° angle. Our product will install snug against the mating pipe flange without voids. The flange body of the rubber expansion joint is difficult to form and many manufacturers radius the edge angles. The resulting void between the mating flange and the edge angle can create flow turbulence and allow for material entrapment or bacterial growth. You can avoid these problems by specifying PROCO Series 230 rubber expansion joints.

Chemical Or Abrasive Service Capability. Expensive metallic designs for chemical service can be replaced with the more cost-effective PROCO Series 230. Built with low-cost chemical resistant elastomers, such as Chlorobutyl, DuPont Dow Elastomer Hypalon® rubber, EPDM, Natural, Neoprene and Nitrile, assures an expansion joint compatible with fluid being pumped or piped (See Table 1). When handling abrasive products such as any solids or slurries, Natural or Neoprene filled arch products should be specified. Please refer to PROCO "Chemical to Elastomer Guide" for recommendations on elastomer chemical compatibility for piping processes.

Exclusive Sealing Bead Means A Quick Seal. PROCO has built an "O-Ring" on each flange face of the Series 230. Available only from PROCO, the Series 230 seals faster with less torque at installation. For these exclusive features, specify the PROCO Series 230 rubber expansion joints.

Specifications Met. PROCO has assigned conservative pressure ratings to the Series 230 rubber expansion joints. The ratings, however, meet the requirements of the Fluid Sealing Association's Rubber Expansion Joint Division Technical Handbook (Sixth Edition), Series C. The pressure ratings for the Series 230 rubber expansion joints have been fully tested and are based on a minimum four-to-one safety factor. For pressure protection with confidence, specify the PROCO Series 230.

Tested Force Pound And Spring Rate Tables. The Series 230 rubber expansion joints are in accordance with and/or lower than the guidelines for spring rate data as listed in the Fluid Sealing Association's Rubber Expansion Joint Division Technical Handbook (Sixth Edition), Table V. Due to a lower, wider arch profile, the PROCO Series 230 will provide more flexibility than conventional spool-type rubber expansion joints. In addition, the lower/wider arch profile coupled with a modified radial tire cord construction will result in lower flange forces. Lower resultant forces mean reduced stress of related piping system components. PROCO is currently testing each rubber expansion joint size and will list actual test data as opposed to listing hypothetical data normally associated with spring rate tables.

Absorbs Vibration • Noise • Shock. The PROCO Series 230 quiet-operating rubber expansion joints are a replacement for "sound transmitting" metallic expansion joints. Sound loses energy traveling axially through an expansion joint. Water hammer, pumping impulses, water-borne noises and other forms of strain-stress-shock are cushioned and absorbed by the molded elastomer expansion joint, not related to piping. Install the Series 230 in a system to reduce vibration transmission when the piping section beyond the expansion joint is anchored or sufficiently rigid. For quiet, stress-free systems, specify the PROCO Series 230.

Wide Service Range With Low Cost. Engineered to operate up to 200 PSIG or up to 250°F, the PROCO Series 230 can be specified for a wide range of piping system requirements. Compared to competitive products, you will invest less money when specifying the engineered design and industrial quality of the PROCO Series 230.

Large Inventory Means Same-Day Shipment. We maintain the largest inventory of elastomeric expansion joints in the world. Every size cataloged up to 72" is in stock in a variety of elastomers. We can ship the products you need when you need them! In fact, when it comes to rubber expansion joints, **if PROCO doesn't have them in stock ... nobody does!**

Information • Ordering • Pricing • Delivery. Day or night, weekends and holidays ... the PROCO phones are monitored 24 hours around the clock. When you have a question, you can call us.

Toll-Free Phone 800 / 344-3246 USA/CANADA
 International Calls 209 / 943-6088
 Fax 209 / 943-0242
 E-mail sales@procoproducts.com
 Web Site www.procoproducts.com
 Weekday office hours are 5:30 a.m. to 5:15 p.m. Pacific Time.

Table 1: Available Styles • Materials • Temperatures

For Specific Elastomer Recommendations, See: PROCO™ "Chemical To Elastomer Guide"						
PROCO Style Numbers		Cover ^{2,3} Elastomer	Tube Elastomer	Maximum Operating Temp. °F (°C)	Branding Label Color	F.S.A. Material Class
Filled Arch (Single) ¹	Open Arch (Single)					
FA231/BB	231/BB	Chlorobutyl	Chlorobutyl	250° (121°)	Black	STD. III
FA231/EE	231/EE	EPDM	EPDM	250° (121°)	Red	STD. III
FA231/NH	231/NH	Neoprene	Hypalon®	212° (100°)	Green	STD. II
FA231/NN	231/NN	Neoprene	Neoprene	225° (107°)	Blue	STD. II
FA231/NP	231/NP	Neoprene	Nitrile	212° (100°)	Yellow	STD. II
FA231/NR	231/NR	Neoprene	Natural	180° (82°)	White	STD. I

Notes: Hypalon® is a registered trademark of DuPont Dow Elastomers.
 All products are reinforced with steel and fabric materials.
 1. Style numbers above reflect one arch. Products are also available in Styles 232 and 233.
 2. Expansion joint "cover" can be coated with Hypalon® on special order.
 3. Styles with Neoprene covers meet all requirements of U.S.C.G.

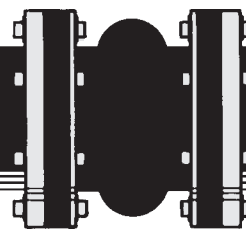

Protecting Piping And
Equipment Systems
From Stress/Motion

Series 230
Page 2 of 10

Rev. 06 04/10 PDF

PROCO

STYLE

231/221

single wide arch spool type
rubber expansion joints



Table 2: Sizes • Movements • Forces • Weights

See Notes Page 7

EXPANSION JOINT SIZE Nom. I.D. x Inch / (mm)	NEUTRAL LENGTH Inch / (mm)	EXPANSION JOINT STYLE	231 / 221 Movement Capability: From Neutral Position					Spring Rate Capability Based on 1" of Movement at Zero Pressure Conditions					Operating ⁴ Conditions			Weights ⁵ lbs / (kgs)		
			Axial Compression Inch / (mm)	Axial Extension Inch / (mm)	Lateral Deflection Inch / (mm)	Angular ¹ Deflection Degrees	Torsional ² Rotation Degrees	Force lbs per 1" rated Compression	Force lbs per 1" rated Extension	Force lbs per 1" rated Lateral Deflection	Force lb-in per 1" rated Angular	Thrust Factor ³ In ² / (cm ²)	Positive PSIG/ (Bar)	Vacuum Inches of Hg/ (mm of Hg)	Expansion Joint Assembly	Retaining Ring Set	Control ⁶ Rod Assembly	
1 (25)	6 (152)	231	1.2 (30)	0.6 (15)	0.6 (15)	50.4	2.0	U N D E R C U R R E N T T E S T I N G	5.12 (33)	200 (14.0)	26 (660)	2.0 (0.8)	2.0 (0.8)	2.3 (1.0)				
		231	1.2 (30)	0.6 (15)	0.6 (15)	43.1	2.0		6.20 (40)	200 (14.0)	26 (660)	2.5 (1.1)	2.5 (1.1)	2.3 (1.0)				
1.25 (32)	6 (152)	231	1.2 (30)	0.6 (15)	0.6 (15)	38.1	2.0		7.44 (48)	200 (14.0)	26 (660)	3.0 (1.4)	2.5 (1.1)	2.3 (1.0)				
		231	1.2 (30)	0.6 (15)	0.6 (15)													
1.5 (40)	6 (152)	231																
		231																
		231	1.4 (35)	0.7 (18)	0.6 (15)	34.2	2.0		12.40 (80)	200 (14.0)	26 (660)	4.0 (1.8)	4.0 (1.8)	2.8 (1.3)				
		231																
2 (50)	7 (178)	231																
	8 (203)	231																
	9 (229)	231	1.4 (35)	0.7 (18)	0.6 (15)	27.6	2.0		15.66 (101)	200 (14.0)	26 (660)	4.5 (2.0)	4.5 (2.0)	2.8 (1.3)				
	10 (254)	231																
2.5 (65)	12 (305)	231																
	6 (152)	231																
	7 (178)	231																
	8 (203)	231	1.4 (35)	0.7 (18)	0.6 (15)	23.0	2.0	19.38 (125)	200 (14.0)	26 (660)	5.5 (2.5)	5.5 (2.5)	2.8 (1.3)					
3 (80)	9 (229)	231																
	10 (254)	231																
	12 (305)	231																
	6 (152)	231																
3.5 (90)	7 (178)	231																
	8 (203)	221	0.6 (15)	0.3 (8)	0.56 (14)	9.0	2.0	23.18 (150)	200 (14.0)	26 (660)	6.0 (2.7)	6.0 (2.7)	2.8 (1.3)					
	9 (229)	221																
	10 (254)	221																
4 (100)	12 (305)	221																
	6 (152)	231																
	7 (178)	231																
	8 (203)	231	1.4 (35)	0.7 (18)	0.6 (15)	18.8	2.0	27.90 (180)	200 (14.0)	26 (660)	8.0 (3.6)	8.0 (3.6)	2.8 (1.3)					
4 (100)	9 (229)	231																
	10 (254)	231																
4 (100)	12 (305)	231																
	6 (152)	231																

231/221 continued



Table 2: Sizes • Movements • Forces • Weights

See Notes Page 7

EXPANSION JOINT SIZE Nom. I.D. X Inch / (mm)	NEUTRAL LENGTH Inch / (mm)	EXPANSION JOINT STYLE	231 / 221 Movement Capability: From Neutral Position					Spring Rate Capability Based on 1" of Movement at Zero Pressure Conditions					Operating ⁴ Conditions		Weights ⁵ lbs / (kgs)			
			Axial Compression Inch / (mm)	Axial Extension Inch / (mm)	Lateral Deflection Inch / (mm)	Angular ¹ Deflection Degrees	Torsional ² Rotation Degrees	Force lbs per 1" rated Compression	Force lbs per 1" rated Extension	Force lbs per 1" rated Lateral Deflection	Force ft-lbs per 1" rated Angular	Thrust Factor ³ Inz / (cm2)	Positive PSIG/ (Bar)	Vacuum Inches of Hg/ (mm of Hg)	Expansion Joint Assembly	Retaining Ring Set	Control ⁶ Rod Assembly	
5	(125)	6 (152)	231															
		7 (178)	231															
		8 (203)	231	1.4 (35)	0.7 (18)	0.6 (15)	15.2	2.0				38.13 (246)	190 (13.0)	26 (660)	9.0 (4.1)	8.5 (3.9)	4.0 (1.8)	
		9 (229)	231															
		10 (254)	231															
6	(150)	6 (152)	231															
		7 (178)	231															
		8 (203)	231	1.4 (35)	0.7 (18)	0.6 (15)	12.8	2.0				49.91 (322)	190 (13.0)	26 (660)	11.0 (5.0)	9.5 (4.3)	4.0 (1.8)	
		9 (229)	231															
		10 (254)	231															
8	(200)	6 (152)	231															
		7 (178)	231															
		8 (203)	231															
		9 (229)	231	1.4 (35)	0.7 (18)	0.6 (15)	9.7	2.0				77.97 (503)	190 (13.0)	26 (660)	15.0 (6.8)	14.5 (6.6)	8.0 (3.6)	
		10 (254)	231															
10	(250)	6 (152)	221	0.7 (18)	0.4 (10)	0.5 (13)	4.1	2.0				116.97 (755)	190 (13.0)	26 (660)	23.0 (10.4)	17.0 (7.7)	10.0 (4.5)	
		7 (178)	221															
		8 (203)	231															
		9 (229)	231															
		10 (254)	231	1.6 (40)	0.8 (20)	0.8 (20)	9.1	2.0				119.97 (774)	190 (13.0)	26 (660)	23.0 (10.4)	17.0 (7.7)	10.0 (4.5)	
12	(300)	6 (152)	221	0.7 (17)	0.4 (10)	0.5 (13)	3.4	2.0				157.74 (1018)	190 (13.0)	26 (660)	26.5 (12.0)	24.5 (11.0)	10.0 (4.5)	
		7 (178)	221															
		8 (203)	231															
		9 (229)	231															
		10 (254)	231	1.6 (40)	0.8 (20)	0.8 (20)	7.6	2.0				161.18 (1045)	190 (13.0)	26 (660)	34.0 (15.4)	24.5 (11.0)	10.0 (4.5)	
14	(350)	6 (152)	221															
		7 (178)	221															
		8 (203)	231															
		9 (229)	231															
		10 (254)	231	1.6 (40)	0.8 (20)	0.8 (20)	6.5	2.0				210.18 (1356)	130 (9.0)	26 (660)	40.0 (18.1)	27.0 (12.3)	12.0 (5.4)	
		12 (305)	231															
		14 (356)	231															

231/221 continued



Table 2: Sizes • Movements • Forces • Weights

See Notes Page 7

EXPANSION JOINT SIZE Nom. I.D. X Inch / (mm)	NEUTRAL LENGTH Inch / (mm)	EXPANSION JOINT STYLE	231 / 221 Movement Capability: From Neutral Position					Spring Rate Capability Based on 1" of Movement at Zero Pressure Conditions					Operating ⁴ Conditions		Weights ⁵ lbs / (kgs)				
			Axial Compression Inch / (mm)	Axial Extension Inch / (mm)	Lateral Deflection Inch / (mm)	Angular, ¹ Deflection Degrees	Torsional ² Rotation Degrees	Force lbs per 1" rated Compression	Force lbs per 1" rated Extension	Force lbs per 1" rated Lateral Deflection	Force lbs per 1" rated Angular	Thrust Factor ³ Inz / (cm2)	Positive PSIG/ (Bar)	Vacuum Inches of Hg/ (mm of Hg)	Expansion Joint Assembly	Retaining Ring Set	Control ⁶ Rod Assembly		
16	(400)	8 (203)	231																
		9 (229)	231																
		10 (254)	231	1.6 (40)	0.8 (20)	0.8 (20)	5.7	2.0			264.74 (1708)	115 (8.0)	26 (660)	47.0 (21.3)	33.5 (15.2)	15.0 (6.8)			
		12 (305)	231																
		14 (356)	231																
18	(450)	8 (203)	231																
		9 (229)	231																
		10 (254)	231	1.6 (40)	0.8 (20)	0.8 (20)	5.1	2.0			325.50 (2100)	115 (8.0)	26 (660)	56.0 (25.4)	34.0 (15.5)	16.0 (7.2)			
		12 (305)	231																
		14 (356)	231																
20	(500)	8 (203)	231																
		9 (229)	231																
		10 (254)	231	1.6 (40)	0.8 (20)	0.8 (20)	5.7	2.0			392.62 (2533)	115 (8.0)	26 (660)	67.0 (30.4)	38.0 (17.3)	16.0 (7.2)			
		12 (305)	231																
		14 (356)	231																
22	(550)	8 (203)	221	0.8 (20)	0.5 (13)	0.5 (13)	2.6	2.0			483.08 (3117)	100 (7.0)	26 (660)	70.0 (31.8)	44.0 (20.0)	19.0 (8.6)			
		9 (229)	221																
22	(550)	10 (254)	231																
		12 (305)	231	2.0 (51)	1.0 (25)	1.0 (25)	5.2	2.0			481.12 (3104)	100 (7.0)	26 (660)	70.0 (31.8)	44.0 (20.0)	19.0 (8.6)			
		14 (356)	231																
24	(600)	8 (203)	221	0.8 (20)	0.5 (13)	0.5 (13)	2.3	2.0			562.82 (3631)	100 (7.0)	26 (660)	79.0 (35.8)	48.0 (21.8)	19.0 (8.6)			
		9 (229)	221																
24	(600)	10 (254)	231																
		12 (305)	231	2.0 (51)	1.0 (25)	1.0 (25)	4.8	2.0			562.03 (3626)	100 (7.0)	26 (660)	79.0 (35.8)	48.0 (21.8)	20.0 (9.0)			
		14 (356)	231																
26	(650)	10 (254)	231																
		12 (305)	231	2.0 (51)	1.0 (25)	1.0 (25)	4.4	2.0			649.14 (4188)	90 (6.0)	26 (660)	100.0 (45.4)	51.0 (23.1)	20.0 (9.0)			
		14 (356)	231																
28	(700)	10 (254)	231																
		12 (305)	231	2.0 (51)	1.0 (25)	1.0 (25)	4.1	2.0			742.45 (4790)	90 (6.0)	26 (660)	102.0 (46.3)	55.0 (25.0)	28.0 (12.6)			
		14 (356)	231																
30	(750)	9 (229)	221	0.9 (23)	0.6 (15)	0.5 (13)	2.2	2.0			798.58 (5152)	90 (6.0)	26 (660)	117.0 (53.1)	63.0 (28.6)	29.5 (13.3)			
		10 (254)	231																
30	(750)	12 (305)	231	2.0 (51)	1.0 (25)	1.0 (25)	3.8	2.0			842.27 (5434)	90 (6.0)	26 (660)	117.0 (53.1)	63.0 (28.6)	29.5 (13.3)			
		14 (356)	231																

U
N
D
E
R
C
U
R
R
E
N
T
T
E
S
T
I
N
G

231/221 continued



Table 2: Sizes • Movements • Forces • Weights

See Notes Page 7

EXPANSION JOINT SIZE Nom. I.D. X Inch / (mm)	NEUTRAL LENGTH Inch / (mm)	EXPANSION JOINT STYLE	231 / 221 Movement Capability: From Neutral Position					Spring Rate Capability Based on 1" of Movement at Zero Pressure Conditions					Operating ⁴ Conditions		Weights ⁵ lbs / (kgs)			
			Axial Compression Inch / (mm)	Axial Extension Inch / (mm)	Lateral Deflection Inch / (mm)	Angular ¹ Deflection Degrees	Torsional ² Rotation Degrees	Force lbs per 1" rated Compression	Force lbs per 1" rated Extension	Force lbs per 1" rated Lateral Deflection	Force lb-lbs per 1" rated Angular	Thrust Factor ³ Inz / (cmZ)	Positive PSIG/ (Bar)	Vacuum Inches of Hg/ (mm of Hg)	Expansion Joint Assembly	Retaining Ring Set	Control ⁶ Rod Assembly	
32 (800)	10 (254)	231																
	12 (305)	231	2.0 (51)	1.0 (25)	1.0 (25)	3.6	2.0			948.29 (6118)	90 (6.0)	26 (660)	120.0 (54.4)	68.0 (30.8)	33.0 (14.9)			
	14 (356)	231																
	10 (254)	231																
34 (850)	12 (305)	231	2.0 (51)	1.0 (25)	1.0 (25)	3.4	2.0			1060.51 (6842)	90 (6.0)	26 (660)	122.0 (55.3)	72.0 (32.7)	43.0 (19.5)			
	14 (356)	231																
	10 (254)	231																
	12 (305)	231	2.0 (51)	1.0 (25)	1.0 (25)	3.2	2.0			1179.09 (7607)	90 (6.0)	26 (660)	143.0 (64.9)	76.0 (34.5)	43.0 (19.5)			
36 (900)	14 (356)	231																
	10 (254)	231																
	12 (305)	231	2.0 (51)	1.0 (25)	1.0 (25)	3.0	2.0			1303.86 (8412)	90 (6.0)	26 (660)	162.0 (73.5)	86.0 (39.0)	43.0 (19.5)			
	14 (356)	231																
	10 (254)	231																
	12 (305)	231	2.0 (51)	1.0 (25)	1.0 (25)	2.9	2.0			1434.99 (9258)	90 (6.0)	26 (660)	173.0 (78.5)	100.0 (45.5)	43.0 (19.5)			
40 (1000)	14 (356)	231																
	12 (305)	231	2.4 (61)	1.2 (30)	1.1 (28)	3.3	2.0			1628.28 (10505)	80 (5.5)	26 (660)	193.0 (87.5)	100.0 (45.5)	44.0 (20.0)			
	14 (356)	231																
	12 (305)	231	2.4 (61)	1.2 (30)	1.1 (28)	3.1	2.0			1774.44 (11448)	80 (5.5)	26 (660)	198.0 (89.8)	104.0 (37.2)	44.0 (20.0)			
42 (1050)	14 (356)	231																
	12 (305)	231	2.4 (61)	1.2 (30)	1.1 (28)	3.0	2.0			1926.81 (12431)	80 (5.5)	26 (660)	205.0 (93.0)	127.0 (57.6)	44.0 (20.0)			
	14 (356)	231																
	12 (305)	231	2.4 (61)	1.2 (30)	1.1 (28)	2.9	2.0			2085.53 (13455)	80 (5.5)	26 (660)	211.0 (95.7)	132.0 (59.9)	44.0 (20.0)			
44 (1100)	14 (356)	231																
	12 (305)	231	2.4 (61)	1.2 (30)	1.1 (28)	2.8	2.0			2250.45 (14519)	80 (5.5)	26 (660)	240.0 (108.8)	134.0 (60.0)	44.0 (20.0)			
	14 (356)	231																
	12 (305)	231	2.4 (61)	1.2 (30)	1.1 (28)	2.6	2.0			2421.72 (15624)	80 (5.5)	26 (660)	256.0 (116.1)	136.0 (61.7)	60.0 (27.0)			
46 (1150)	14 (356)	231																
	12 (305)	231	2.4 (61)	1.2 (30)	1.1 (28)	2.6	2.0			2599.35 (16770)	80 (5.5)	26 (660)	265.0 (120.1)	150.0 (68.0)	63.0 (28.6)			
	14 (356)	231																
	12 (305)	231	2.4 (61)	1.2 (30)	1.1 (28)	2.5	2.0			2931.67 (18914)	80 (5.5)	26 (660)	288.0 (130.6)	165.0 (70.8)	63.0 (28.6)			
48 (1200)	14 (356)	231																
	12 (305)	231	2.4 (61)	1.2 (30)	1.1 (28)	2.4	2.0			3011.34 (19428)	80 (5.5)	26 (660)	300.0 (136.1)	190.0 (86.2)	66.2 (30.0)			
	14 (356)	231																
	12 (305)	231	2.4 (61)	1.2 (30)	1.1 (28)	2.3	2.0			3208.97 (20703)	80 (5.5)	26 (660)	310.0 (140.6)	200.0 (90.7)	68.3 (31.2)			
50 (1250)	14 (356)	231																
	12 (305)	231	2.4 (61)	1.2 (30)	1.1 (28)	2.1	2.0			3839.51 (24771)	80 (5.5)	26 (660)	350.0 (158.7)	240.0 (108.8)	71.0 (32.2)			
	14 (356)	231																
	12 (305)	231	2.4 (61)	1.2 (30)	1.1 (28)	2.0	2.0			4062.24 (28208)	70 (5.0)	26 (660)	368.8 (166.9)	227.0 (103.0)	76.3 (34.6)			
52 (1300)	14 (356)	231																
	12 (305)	231																
	14 (356)	231																
	12 (305)	231																
54 (1350)	14 (356)	231																
	12 (305)	231																
	14 (356)	231																
	12 (305)	231																
56 (1400)	14 (356)	231																
	12 (305)	231																
	14 (356)	231																
	12 (305)	231																
58 (1450)	14 (356)	231																
	12 (305)	231																
	14 (356)	231																
	12 (305)	231																
60 (1500)	14 (356)	231																
	12 (305)	231																
	14 (356)	231																
	12 (305)	231																
66 (1650)	14 (356)	231																
	12 (305)	231																
	14 (356)	231																
	12 (305)	231																
68 (1700)	14 (356)	231																
	12 (305)	231																

U
N
D
E
R
C
U
R
R
E
N
T
T
E
S
T
I
N
G

Table 2: Sizes • Movements • Forces • Weights											See Notes Below						
EXPANSION JOINT SIZE Nom. I.D. x Inch / (mm)	NEUTRAL LENGTH Inch / (mm)	EXPANSION JOINT STYLE	231 / 221 Movement Capability: From Neutral Position						Spring Rate Capability Based on 1" of Movement at Zero Pressure Conditions				Operating ⁴ Conditions		Weights ⁵ lbs / (kgs)		
			Axial Compression Inch / (mm)	Axial Extension Inch / (mm)	Lateral Deflection Inch / (mm)	Angular ¹ Deflection Degrees	Torsional ² Rotation Degrees	Force lbs per 1" rated Compression	Force lbs per 1" rated Extension	Force lbs per 1" rated Lateral Deflection	Force ft-lbs per 1" rated Angular	Thrust Factor ³ Inz / (cm ²)	Positive PSIG/ (Bar)	Vacuum Inches of Hg/ (mm of Hg)	Expansion Joint Assembly	Retaining Ring Set	Control ⁶ Rod Assembly
72 (1800)	<u>12</u> (305)	231	2.4 (61)	1.2 (30)	1.1 (28)	1.9	2.0	U N D E R C U R R E N T T E S T I N G	4526.62 (29244)	70 (5.0)	26 (660)	390.0 (176.9)	290.0 (131.5)	87.0 (39.4)			
	<u>14</u> (356)	231	2.3 (57)	1.2 (30)	1.0 (25)	1.8	2.0		5410.60 (34907)	85 (6.0)	26 (660)	410.0 (186.0)	315.0 (142.9)	103.0 (46.7)			
78 (1950)	<u>12</u> (305)	231	2.3 (57)	1.2 (30)	1.0 (25)	1.6	2.0		6221.13 (40136)	85 (6.0)	26 (660)	440.0 (200.0)	350.0 (158.0)	113.0 (51.3)			
	<u>14</u> (356)	231	2.3 (57)	1.2 (30)	1.0 (25)	1.6	2.0		7088.11 (45730)	85 (6.0)	26 (660)	448.0 (203.1)	363.0 (164.6)	125.0 (56.7)			
84 (2100)	<u>12</u> (305)	231	2.3 (57)	1.2 (30)	1.0 (25)	1.4	2.0		8011.85 (51689)	85 (6.0)	26 (660)	466.0 (211.3)	367.0 (170.5)	125.0 (56.7)			
	<u>14</u> (356)	231	2.3 (57)	1.2 (30)	1.0 (25)	1.3	2.0		8992.02 (58013)	85 (6.0)	26 (660)	485.8 (220.0)	395.0 (179.1)	137.0 (62.1)			
90 (2250)	<u>12</u> (305)	231	2.3 (57)	1.2 (30)	1.1 (28)	1.2	2.0		10028.75 (64702)	85 (6.0)	26 (660)	510.0 (231.3)	425.0 (192.7)	139.0 (63.0)			
	<u>14</u> (356)	231	2.3 (57)	1.2 (30)	1.0 (25)	1.1	2.0		12271.84 (79173)	85 (6.0)	26 (660)	540.0 (244.9)	565.0 (256.2)	151.0 (65.8)			

Neutral lengths underlined are the recommended minimum lengths.
Metric Conversion Formula: Nominal I.D.: in. x 25 = mm; Dimensions: in. x 25.4 = mm; Pressure: PSIG x .069 = Bar

NOTES:

- The degree of angular movement is based on the maximum rated extension.
- Torsional movement is expressed when the expansion joint is at its neutral length.
- To determine "end thrust", multiply thrust factor by operating pressure of system.
- Pressure rating is based on 170°F operating temperature with a 4:1 safety factor. At higher temperatures, the pressure rating is reduced slightly. Hydrostatic testing at 1.5 times rated or working pressure for 10 minutes is available upon request.
- Weights are approximate and vary due to OAL.
- Control rod unit weight consists of one rod with washers, nuts and two control rod plates. Multiply number of control rods needed for application (as specified in the Fluid Sealing Association's Technical Handbook) to determine correct weights.

Toll Free Phone (800) 344-3246
International Calls (209) 943-6088
Facsimile (209) 943-0242
E-mail sales@procoproducts.com
Web Site http://www.procoproducts.com

Filled Arch Rubber Expansion Joints

Known as Style FA231 or Style FA221 the Series FA230 Rubber Expansion Joints are designed to eliminate flow turbulence and collection of solids in the arch core. Filled Arch Rubber Expansion Joints can be found in applications such as sludge, slurries or other heavy solids where material entrapment, high flow velocity or high abrasion conditions exist. Filled arch products are manufactured with seamless tube and are built as an integral part of the carcass. Although the tube is made of a low durometer filler stock, movement ratings of the Style FA231 or Style FA221 are 50% less than those movements listed in the table above. PROCO can manufacture any size listed in the table above.

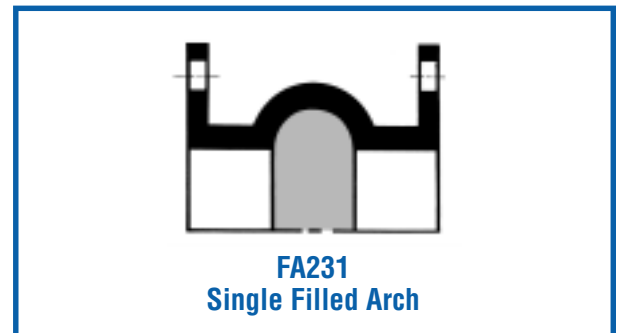

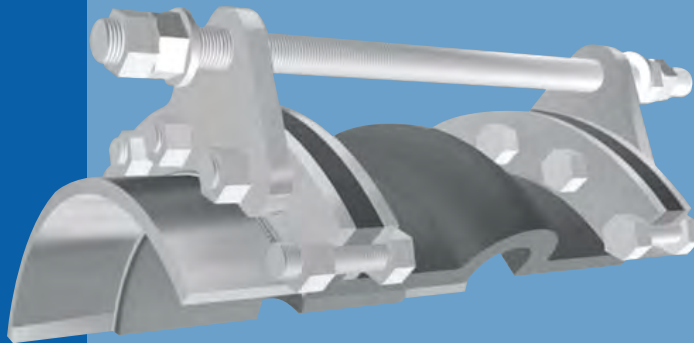

Figure 1: Limit Rod
Consult the systems engineer for proper nut settings prior to system operation.

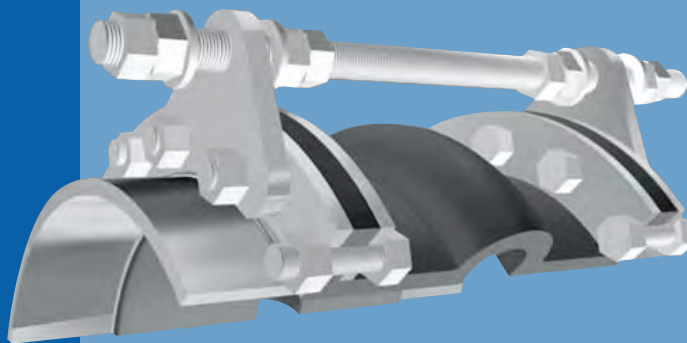

Figure 2: Limit/Control Rod
Rods with internal nut configuration must be specified at time of inquiry.

Definition — A control unit assembly is a system of two or more control rod units (limit rods, tie rods or compression sleeves) placed across an expansion joint from flange to flange to minimize possible damage caused by excessive motion of a pipeline. The failure of an anchor or some other piece of equipment in a pipeline can cause excessive motion. The control unit assemblies can be set at the maximum allowable expansion and/or contraction of the rubber expansion joint. When used in this manner, control units are an additional safety factor and can minimize possible damage to adjacent equipment.

Use of Control Units with Rubber Expansion Joints

Rubber expansion joints must be installed between two fixed anchor points in a piping system. The pipe system must be rigidly anchored on both sides of the expansion joint to control expansion or contraction of the line. Piping anchors must be capable of withstanding the line thrusts generated by internal pressure or wide temperature fluctuations. When proper anchoring cannot be provided, **CONTROL UNITS ARE REQUIRED.**

Listed below are three (3) control unit configurations supplied by PROCO and are commonly used with rubber expansion joints in piping systems.

Figure 1 — Known as a **LIMIT ROD**, this control unit configuration will allow an expansion joint to extend to a predetermined extension setting. Nuts shall be field set to no more than the maximum allowable extension movement of a rubber expansion joint. Refer to Tables 2, 3, or 4 in this manual. **Consult the systems engineer for proper nut settings prior to system operation.**

Figure 2 — Known as a **LIMIT/CONTROL ROD**, this control unit configuration is used to allow specified pipe expansion (expansion joint axial compression) and pipe contraction (expansion joint axial extension) movements. Nuts shall be field set to no more than the maximum allowable extension or compression of a rubber expansion joint. Refer to Tables 2, 3 or 4 in this Manual.

Internal and external nuts can also be field set to allow for no movement in the horizontal plane. This setting will allow the rubber to move laterally while keeping expansion joint thrust forces low on adjacent equipment. Spherical washers can also be furnished (upon request) to combat any potential “nut to plate” binding during offset. **Limit/Control rods with internal nuts must be specified at the time of inquiry. Consult the systems engineer for proper nut settings prior to system operation.**

Figure 3 — Known as a **COMPRESSION SLEEVE**, this configuration is used to allow for specified pipe expansion (expansion joint axial compression) and pipe contraction (expansion joint extension) movements. Nuts shall be field set to no more than the maximum allowable extension of a rubber expansion joint. Refer to Tables 2, 3, or 4 in this manual. PROCO will manufacture each compression sleeve to allow for no axial movement unless otherwise specified by the purchaser. Compression sleeves shall be field trimmed to meet required allowable axial movement as set forth by system requirements. Spherical washers can also be furnished (upon request) to combat any potential “nut to plate” binding during offset. **Consult the systems engineer for proper sleeve lengths prior to system operation.**

Important Control Unit Considerations — The number of rods, control rod diameters and control rod plate thicknesses are important considerations when specifying control units for an application. As a minimum, specifying engineers or purchasers shall follow the guidelines as set forth in Appendix C of the Fluid Sealing Association’s Rubber Expansion Joint Division Technical Handbook (Sixth Edition). PROCO engineers its control unit assemblies to system requirements. Our designs incorporate an allowable stress of 65% of material yield for each rod and plate (rod and plate material to be specified by purchaser). Therefore, it is important to provide pressure and temperature ratings to PROCO when requesting control units for rubber expansion joints. It is also important to provide adjacent mating flange thickness or mating specifications to insure correct rod lengths are provided.

Toll Free Phone	(800) 344-3246
International Calls	(209) 943-6088
Facsimile	(209) 943-0242
E-mail	sales@procoproducts.com
Web Site	http://www.procoproducts.com

COMPRESSION SLEEVES

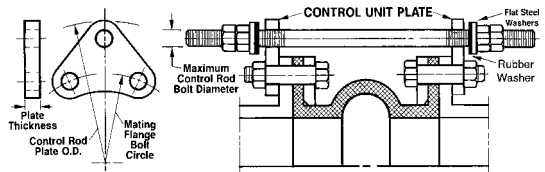

Table 5: Control Unit Plate Detail *See Notes Below*

NOMINAL SIZE Inch / (mm)	CONTROL ROD ¹ PLATE O.D. Inch / (mm)	MAXIMUM ² PLATE THK Inch / (mm)	MAXIMUM ³ ROD DIAMETER Inch / (mm)
1	(25)	8.375 (212.7)	0.625 (15.9)
1.25	(32)	8.750 (222.3)	0.625 (15.9)
1.5	(40)	9.125 (231.8)	0.625 (15.9)
2	(50)	10.125 (257.2)	0.625 (15.9)
2.5	(65)	11.125 (282.6)	1.000 (25.4)
3	(80)	11.625 (295.3)	1.000 (25.4)
3.5	(90)	12.625 (320.7)	1.000 (25.4)
4	(100)	13.125 (333.4)	1.000 (25.4)
5	(125)	14.125 (358.8)	1.000 (25.4)
6	(150)	15.125 (384.2)	1.000 (25.4)
8	(200)	19.125 (485.8)	1.000 (25.4)
10	(250)	21.625 (549.3)	1.000 (25.4)
12	(300)	24.625 (625.5)	1.000 (25.4)
14	(350)	26.625 (676.3)	1.000 (25.4)
16	(400)	30.125 (765.2)	1.250 (31.8)
18	(450)	31.625 (803.3)	1.250 (31.8)
20	(500)	34.125 (866.8)	1.250 (31.8)
22	(550)	36.125 (917.6)	1.250 (31.8)
24	(600)	38.625 (981.1)	1.250 (31.8)
26	(650)	40.875 (1038.2)	1.250 (31.8)
28	(700)	44.125 (1120.8)	1.500 (38.1)
30	(750)	46.375 (1177.9)	1.500 (38.1)
32	(800)	49.375 (1254.1)	1.500 (38.1)
34	(850)	52.375 (1330.3)	1.750 (44.5)
36	(900)	54.625 (1387.5)	1.750 (44.5)
38	(950)	57.375 (1457.3)	1.750 (44.5)
40	(1000)	58.375 (1482.7)	1.500 (38.1)
42	(1050)	61.625 (1565.3)	1.500 (38.1)
44	(1100)	63.875 (1622.4)	1.750 (44.5)
46	(1150)	65.875 (1673.2)	1.750 (44.5)
48	(1200)	68.125 (1730.4)	1.750 (44.5)
50	(1250)	70.375 (1787.5)	1.750 (44.5)
52	(1300)	73.625 (1870.1)	2.000 (50.8)
54	(1350)	75.875 (1927.2)	2.000 (50.8)
56	(1400)	78.375 (1990.7)	2.000 (50.8)
58	(1450)	80.625 (2047.9)	2.000 (50.8)
60	(1500)	82.625 (2098.7)	2.000 (50.8)
66	(1650)	89.625 (2276.5)	2.000 (50.8)
68	(1700)	91.875 (2333.6)	2.000 (50.8)
72	(1800)	96.125 (2441.6)	2.000 (50.8)
78	(2000)	103.125 (2619.4)	2.000 (50.8)
84	(2150)	109.875 (2790.8)	2.250 (57.2)
90	(2300)	117.125 (2975.0)	2.250 (57.2)
96	(2450)	124.625 (3165.9)	2.500 (63.5)
102	(2500)	131.375 (3336.5)	2.500 (63.5)
108	(2750)	138.125 (3508.4)	2.500 (63.5)
120	(3050)	152.125 (3864.0)	2.500 (63.5)
132	(3350)	166.625 (4232.2)	3.250 (82.6)
144	(3650)	180.750 (4591.1)	3.500 (88.9)

Also available with spherical washer

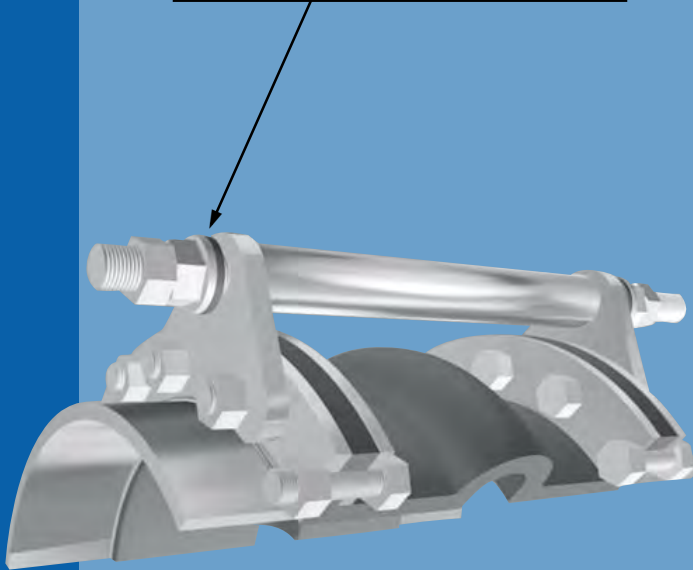
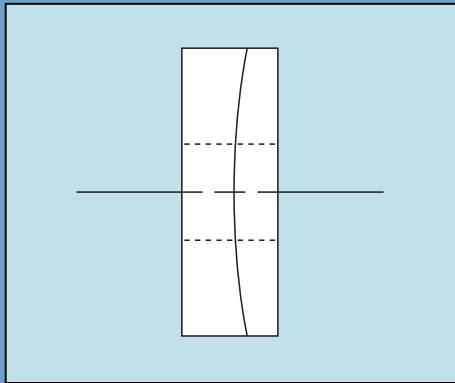

Figure 3: Compression Sleeves
Consult the systems engineer for proper sleeve lengths prior to system operation.

Metric Conversion: Nominal I.D.: in. x 25 = mm; Dimensions: in. x 25.4 = mm; Pressure: PSIG x .069 = Bar

Number of Control Units is dependent upon pressure and temperature of system. Refer to Fluid Sealing Association's - REJ Division Manual, Appendix C (Sixth Edition) for **minimum** number of control units (per pressure rating) required for a rubber expansion joint when specified.

Values listed in this table are maximum values based on PROCO'S engineering data.

1. Control rod plate O.D. installed dimension is based on a **maximum** O.D. PROCO would supply. (Figures 2 and 3.)

2. Plate thickness is based on a **maximum** width PROCO would use to design a control rod plate.

3. Control rod diameter is based on a **maximum** diameter PROCO would use to design a control rod.

Series 230 Drilling Chart

Split Retaining Ring

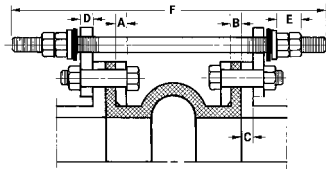
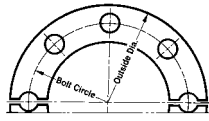

- A - Retaining Ring Thickness
- B - Rubber Flange Thickness
- C - Adjacent Mating Flange Thickness
- D - Control Unit Plate Thickness
- E - Double Nut Thickness is determined by Control Rod Diameter
- F - Control Rod Bolt Length is determined by A through E + OAL¹

Table 6: Standard Drilling for PROCO Series 230/220 Rubber Expansion Joints **Thickness of Materials for PROCO Series 230/220 Rubber Expansion Joints**

NOMINAL PIPE SIZE EXPANSION JOINT I.D. Inch / (mm)	125/150# Flange Dimensions ²				Material Thickness ³ for Bolt Length Requirements			
	FLANGE O.D. Inch / (mm)	BOLT CIRCLE Inch / (mm)	NO. OF HOLES	SIZE OF HOLES	RETAINING RING THICKNESS Inch / (mm)	RUBBER FLANGE THICKNESS Inch / (mm)	ADJACENT MATING FLANGE THICKNESS	MAX. CONTROL ³ ROD PLATE THICKNESS Inch / (mm)
1 (25)	4.25 (107.95)	3.13 (79.50)	4	0.625 (15.9)	0.375 (9.53)	0.472 (11.99)	CUSTOMER TO SPECIFY	0.625 (15.9)
1.25 (32)	4.63 (117.60)	3.50 (88.90)	4	0.625 (15.9)	0.375 (9.53)	0.472 (11.99)		0.625 (15.9)
1.5 (40)	5.00 (127.00)	3.88 (98.55)	4	0.625 (15.9)	0.375 (9.53)	0.472 (11.99)		0.375 (9.5)
2 (50)	6.00 (152.40)	4.75 (120.65)	4	0.750 (19.1)	0.375 (9.53)	0.472 (11.99)		0.500 (12.7)
2.5 (65)	7.00 (177.80)	5.50 (139.70)	4	0.750 (19.1)	0.375 (9.53)	0.472 (11.99)		0.500 (12.7)
3 (80)	7.50 (190.50)	6.00 (152.40)	4	0.750 (19.1)	0.375 (9.53)	0.472 (11.99)		0.500 (12.7)
3.5 (90)	8.50 (215.90)	7.00 (177.80)	8	0.750 (19.1)	0.375 (9.53)	0.472 (11.99)		0.625 (15.9)
4 (100)	9.00 (228.60)	7.50 (190.50)	8	0.750 (19.1)	0.375 (9.53)	0.472 (11.99)		0.625 (15.9)
5 (125)	10.00 (254.00)	8.50 (215.90)	8	0.875 (22.2)	0.375 (9.53)	0.551 (14.00)		0.500 (12.7)
6 (150)	11.00 (279.40)	9.50 (241.30)	8	0.875 (22.2)	0.375 (9.53)	0.551 (14.00)		0.500 (12.7)
8 (200)	13.50 (342.90)	11.75 (298.45)	8	0.875 (22.2)	0.375 (9.53)	0.630 (16.00)		0.625 (15.9)
10 (250)	16.00 (406.40)	14.25 (361.95)	12	1.000 (25.4)	0.375 (9.53)	0.630 (16.00)		0.750 (19.1)
12 (300)	19.00 (482.60)	17.00 (431.80)	12	1.000 (25.4)	0.375 (9.53)	0.748 (19.00)		0.750 (19.1)
14 (350)	21.00 (533.40)	18.75 (476.25)	12	1.125 (28.6)	0.375 (9.53)	0.866 (22.00)		0.750 (19.1)
16 (400)	23.50 (596.90)	21.25 (539.75)	16	1.125 (28.6)	0.375 (9.53)	0.866 (22.00)		1.000 (25.4)
18 (450)	25.00 (635.00)	22.75 (577.85)	16	1.250 (31.8)	0.375 (9.53)	0.866 (22.00)		1.000 (25.4)
20 (500)	27.50 (698.50)	25.00 (635.00)	20	1.250 (31.8)	0.375 (9.53)	0.984 (25.00)		1.000 (25.4)
22 (550)	29.50 (749.30)	27.25 (692.15)	20	1.375 (34.9)	0.375 (9.53)	0.984 (25.00)		1.000 (25.4)
24 (600)	32.00 (812.80)	29.50 (749.30)	20	1.375 (34.9)	0.375 (9.53)	0.984 (25.00)		1.000 (25.4)
26 (650)	34.25 (869.95)	31.75 (806.45)	24	1.375 (34.9)	0.375 (9.53)	0.984 (25.00)		1.000 (25.4)
28 (700)	36.50 (927.10)	34.00 (863.60)	28	1.375 (34.9)	0.375 (9.53)	0.984 (25.00)		1.250 (31.8)
30 (750)	38.75 (984.25)	36.00 (914.40)	28	1.375 (34.9)	0.375 (9.53)	0.984 (25.00)		1.500 (38.1)
32 (800)	41.75 (1060.45)	38.50 (977.90)	28	1.625 (41.3)	0.375 (9.53)	0.984 (25.00)		1.250 (31.8)
34 (850)	43.75 (1111.25)	40.50 (1028.70)	32	1.625 (41.3)	0.375 (9.53)	0.984 (25.00)		1.500 (38.1)
36 (900)	46.00 (1168.40)	42.75 (1085.85)	32	1.625 (41.3)	0.375 (9.53)	0.984 (25.00)		1.750 (44.5)
38 (950)	48.75 (1238.25)	45.25 (1149.35)	32	1.625 (41.3)	0.375 (9.53)	0.984 (25.00)		1.500 (38.1)
40 (1000)	50.75 (1289.05)	47.25 (1200.15)	36	1.625 (41.3)	0.375 (9.53)	0.984 (25.00)		1.500 (38.1)
42 (1050)	53.00 (1346.20)	49.50 (1257.30)	36	1.625 (41.3)	0.375 (9.53)	1.181 (29.99)		1.500 (38.1)
44 (1100)	55.25 (1403.35)	51.75 (1314.45)	40	1.625 (41.3)	0.375 (9.53)	1.181 (29.99)		1.500 (38.1)
46 (1150)	57.25 (1454.15)	53.75 (1365.25)	40	1.625 (41.3)	0.375 (9.53)	1.181 (29.99)		1.500 (38.1)
48 (1200)	59.50 (1511.30)	56.00 (1422.40)	44	1.625 (41.3)	0.375 (9.53)	1.181 (29.99)		1.750 (44.5)
50 (1250)	61.75 (1568.45)	58.25 (1479.55)	44	1.875 (47.6)	0.375 (9.53)	1.181 (29.99)		1.500 (38.1)
52 (1300)	64.00 (1625.60)	60.50 (1536.70)	44	1.875 (47.6)	0.375 (9.53)	1.181 (29.99)		1.750 (44.5)
54 (1350)	66.25 (1682.75)	62.75 (1593.85)	44	2.000 (50.8)	0.375 (9.53)	1.181 (29.99)		2.000 (50.8)
56 (1400)	68.75 (1746.25)	65.00 (1651.00)	48	1.875 (47.6)	0.375 (9.53)	1.181 (29.99)	2.000 (50.8)	
58 (1450)	71.00 (1803.40)	67.25 (1708.15)	48	1.875 (47.6)	0.375 (9.53)	1.181 (29.99)	2.000 (50.8)	
60 (1500)	73.00 (1854.20)	69.25 (1758.95)	52	2.000 (50.8)	0.375 (9.53)	1.181 (29.99)	2.000 (50.8)	
66 (1650)	80.00 (2032.00)	76.00 (1930.40)	52	2.000 (50.8)	0.375 (9.53)	1.181 (29.99)	2.000 (50.8)	
68 (1700)	82.25 (2089.15)	78.25 (1987.55)	56	2.000 (50.8)	0.375 (9.53)	1.181 (29.99)	2.000 (50.8)	
72 (1800)	86.50 (2197.10)	82.50 (2095.50)	60	2.000 (50.8)	0.375 (9.53)	1.181 (29.99)	2.000 (50.8)	
78 (1950)	93.00 (2362.20)	89.00 (2260.60)	64	2.125 (53.0)	0.375 (9.53)	1.188 (30.18)	2.000 (50.8)	
84 (2100)	99.75 (2533.65)	95.50 (2425.70)	64	2.250 (57.2)	0.375 (9.53)	1.188 (30.18)	2.250 (57.2)	
90 (2250)	106.50 (2705.10)	102.00 (2590.80)	68	2.375 (60.3)	0.375 (9.53)	1.188 (30.18)	2.500 (63.5)	
96 (2400)	113.25 (2876.55)	108.50 (2755.90)	68	2.500 (63.5)	0.375 (9.53)	1.188 (30.18)	2.750 (69.9)	
102 (2550)	120.00 (3048.00)	114.50 (2908.30)	72	2.625 (66.7)	0.375 (9.53)	1.188 (30.18)	2.500 (63.5)	
108 (2700)	126.75 (3219.45)	120.75 (3067.05)	72	2.625 (66.7)	0.375 (9.53)	1.188 (30.18)	2.500 (63.5)	
120 (3000)	140.25 (3562.35)	132.75 (3371.85)	76	2.875 (73.0)	0.375 (9.53)	1.188 (30.18)	2.500 (63.5)	
132 (3300)	153.75 (3905.25)	145.75 (3705.05)	80	3.125 (79.4)	0.375 (9.53)	1.188 (30.18)	2.500 (63.5)	
144 (3600)	167.25 (4248.15)	158.25 (4019.55)	84	3.375 (85.7)	0.375 (9.53)	1.188 (30.18)	2.500 (63.5)	

Metric Conversion Formula: Nominal I.D.: in. x 25 = mm; Dimensions: in. x 25.4 = mm; Pressure: PSIG x .069 = Bar

- Notes: 1. Control rod length is determined by OAL of rubber expansion joint, rated extension, retaining ring thickness, mating flange thickness and number of nuts. Consult PROCO for rod lengths.
- 2. Flange dimensions shown are in accordance with 125/150 pound standards: ANSI B16.1 AWWA C-207 Tables 1 and 2 Class D; AWWA C-207 Table 3 see Class E. Hole size shown is 1/8" larger than AWWA standard.
- 3. Plate thickness is based on a maximum width PROCO would use to design a control rod plate.

Tab 5

General Brochures

seepex.com
all things flow

Here is your conveying solution:
Product group N.



N – Standard pumps

The two ranges of pumps within the product group N form the basis of all seepex progressive cavity pumps. They are available with various rotor/stator geometries (conventional, 6L, and Tricam) and can be applied in virtually all industrial sectors – for conveying thin to viscous media with or without solids.

Joint connection
consisting of just 5 components.
Power transmission through wear resistant, hardened and replaceable joint parts: easily repaired.

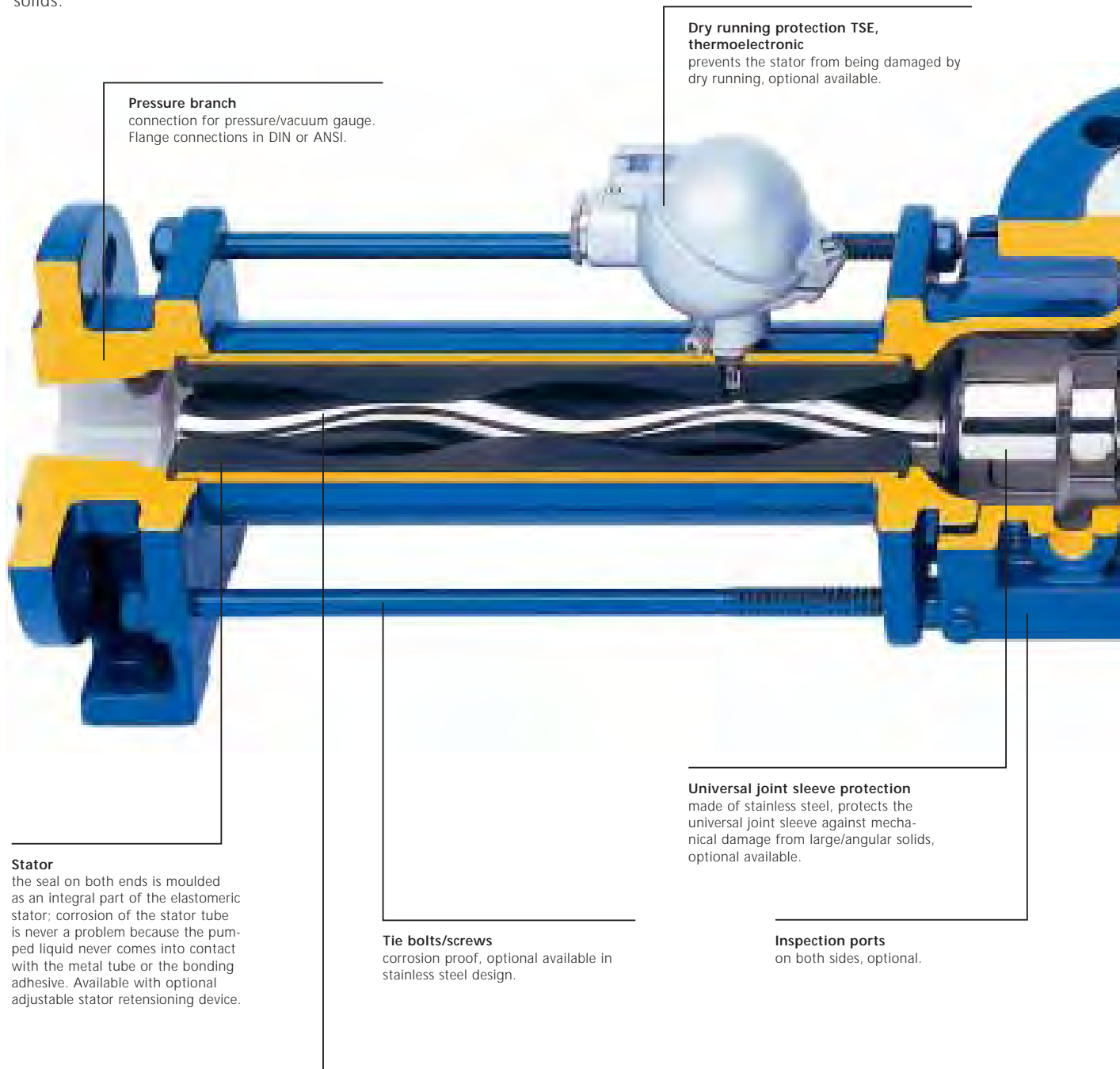

Pressure branch
connection for pressure/vacuum gauge.
Flange connections in DIN or ANSI.

Dry running protection TSE, thermoelectronic
prevents the stator from being damaged by dry running, optional available.

Stator
the seal on both ends is moulded as an integral part of the elastomeric stator; corrosion of the stator tube is never a problem because the pumped liquid never comes into contact with the metal tube or the bonding adhesive. Available with optional adjustable stator retensioning device.

Universal joint sleeve protection
made of stainless steel, protects the universal joint sleeve against mechanical damage from large/angular solids, optional available.

Tie bolts/screws
corrosion proof, optional available in stainless steel design.

Inspection ports
on both sides, optional.

Rotor
wear resistant and corrosion-proof materials, with additional surface treatment.

Coupling rod
for power transmission. Improved design, special designs optional available.

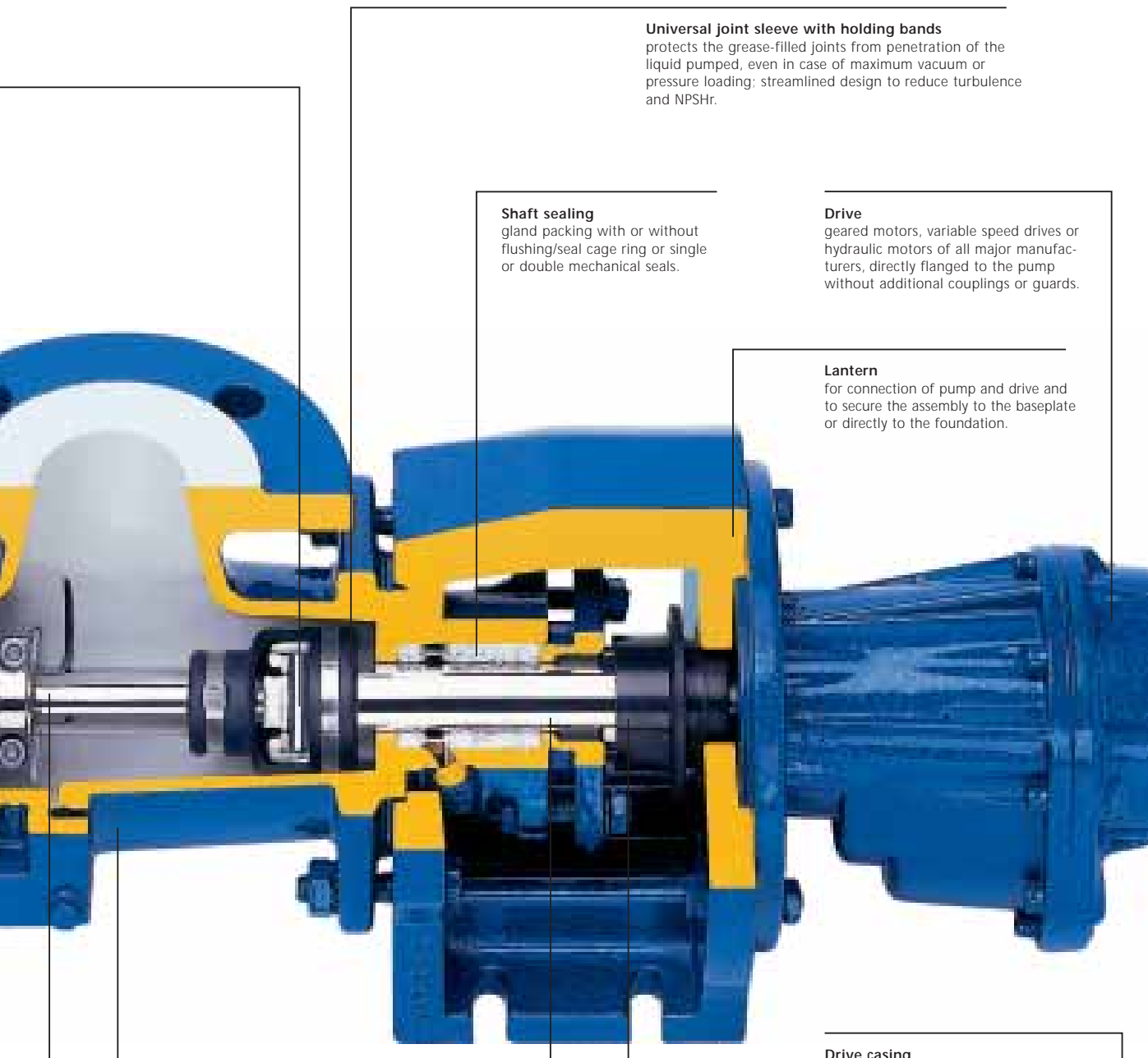

Universal joint sleeve with holding bands
 protects the grease-filled joints from penetration of the liquid pumped, even in case of maximum vacuum or pressure loading; streamlined design to reduce turbulence and NPSHr.

Shaft sealing
 gland packing with or without flushing/seal cage ring or single or double mechanical seals.

Drive
 geared motors, variable speed drives or hydraulic motors of all major manufacturers, directly flanged to the pump without additional couplings or guards.

Lantern
 for connection of pump and drive and to secure the assembly to the baseplate or directly to the foundation.

Suction casing
 with large cross section and designed for smooth flow conditions, with drain plug and connections for pressure/vacuum gauge. Flange connections in DIN or ANSI can be rotated in 90° increments.

Drive casing
 for range NS, drive shaft and bearings can be relubricated, also available with double bearing seals to prevent ingress of dust or moisture.

Plug-in shaft
 connects the drive shaft to the joint; with gland packing the plug-in shaft is used as a shaft protection sleeve; upon request, it is available with wear resistant coating.

Plug-in shaft connection
 for easy dismantling of the pump and drive enabling quick replacement of the rotating parts and shaft seals. The plug-in shaft pin secures the shaft connection to the drive and the splash ring protects the bearing from contamination/gland leakage.

Detail: Range NS

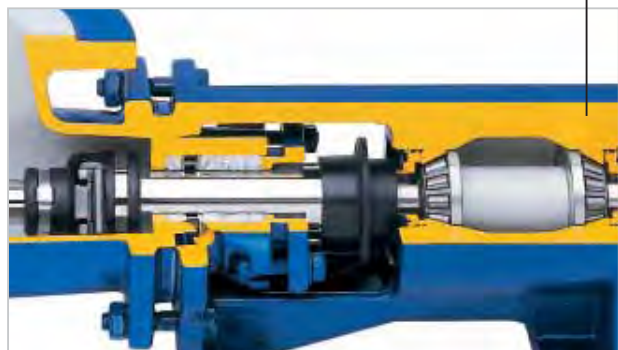

Why standard pumps?

Because they are used in applications such as agriculture, ceramics, chemical and biochemical industry, construction, dyeing and varnishing, electroplating, environment technology, fish industry, food and beverage industry, mining, non-metallic minerals, oil production and offshore technology, petrochemicals, pharmaceutical and cosmetics industry, pulp and paper industry, shipbuilding, sugar industry, supply and waste disposal industry, textile industry, vehicle construction and equipment and wood processing industry.

Features

- Minimal pulsation, controlled flow, so that no pulsation dampers or compensators are required
 - Self-priming, even with air or gas liquid mixtures of up to 9 m (29.5') of water
 - Installation versatility as pumps can be mounted either horizontally or vertically and the suction casing can be rotated
 - Products with solids can be conveyed gently without damage
 - Direction of rotation and fluid flow are reversible
- > Conveying capacity: 30 l/h–500 m³/h (0.13 GPM–2200 GPM),
Pressure: up to 48 bar (720 psi)

Overview of ranges

The drive of BN range pumps is directly flange-mounted to the pump. This means that a separate pump bearing is not necessary and the pump is more compact and less expensive. The plug-in shaft connection between drive and the rotating unit simplifies the replacement of rotating wearing parts and the shaft sealing, thereby making the BN range very service-friendly.

Range BN

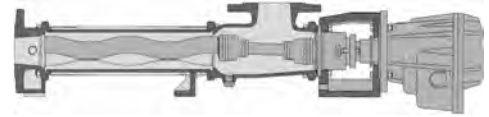

In pumps of the NS range the drives are not directly flange-mounted in favour of a universal configuration of the drives. They have a drive casing and a free shaft end, an elastic coupling or a V-belt and a service-friendly plug-in connection. This simplifies the replacement of the rotating wearing parts and the shaft sealing without dismantling the bearing.

Range NS/N



seepex.com
all things flow

And what can we get flowing for you? Your nearest contact:

Or visit www.seepex.com

N 8.06E