



Weaver

CONSTRUCTION MANAGEMENT

3679 S Huron Street, Suite 404 Englewood, Colorado 80110

Phone: (303) 789-4111 FAX: (303) 789-4310

SUBMITTAL TRANSMITTAL

June 12, 2012

Submittal No: 15800-014.A

PROJECT: **Harold Thompson Regional WRF**
Birdsall Rd.
Fountain, CO 80817
Job No. 2908

ENGINEER: **GMS, Inc.**
611 No. Weber St., #300
Colorado Springs, CO 80903
719-475-2935 Roger Sams

OWNER: **Lower Fountain Metropolitan
Sewage Disposal District**
901 S. Santa Fe Ave.
Fountain, CO 80817
719-382-5303 James Heckman

CONTRACTOR: **Kuck Mechanical Contractors, LLC.**
395 West 67th Street
Loveland, CO 80593
970-461-3553 Melanie Peterson

SUBJECT: Revised Louvers L-6 and L-7 to be in accordance with the "Issued for Construction" drawings dated May 21, 2012

SPEC SECTION: 15800 - Heating & Ventilating

PREVIOUS SUBMISSION DATES: 5/1/12

DEVIATIONS FROM SPEC: ___ YES X NO

CONTRACTOR'S STAMP: This submittal has been reviewed by Weaver Construction Management and, unless indicated otherwise, has been found to be in conformance with the intent of the contract documents.

Contractor's Stamp:

Date: 6/12/12

Reviewed by: John Jacob

(x) Reviewed Without Comments

() Reviewed With Comments

Engineer's Stamp:

ENGINEER'S

COMMENTS: _____



395 West 67th Street
P.O. Box 388
Loveland, CO 80539-0388
Phone: (970) 461-3553
Fax: (970) 461-3443

DATE: 05/01/12

SENT TO: Weaver General Contractors

Attn: John Jacob

JOB: Harold D. Thompson WRF (#01135)
9001 Birdsell Rd.
Fountain, CO 80817

SUBMITTAL NO.: 00021

SUBMITTAL DUE:

PACKAGE: n/a

VENDOR NAME: CFM

SPECIFICATION #: 15800

SUBJECT: P&D Bldg. - Louvers

REVIEW DETAILS:

Review #: 1	Received: 04/13/12	Priority: Normal
Desc: P&D Bldg. - Louvers	Sent: 05/01/12	Status: Approved w/ Note
Reviewer: John Jacob	Returned: 05/25/12	Sepias: 0
Weaver General Contractors	Forwarded: 05/30/12	Prints: 0
Review #: 2	Received: 06/12/12	Priority: Normal
Desc: P&D Louvers L-6/L-7	Sent: 06/12/12	Status: Open
Reviewer: John Jacob	Returned:	Sepias: 0
Weaver General Contractors	Forwarded:	Prints: 0

NOTES: Louvers L-6 & L-7 have been revised to reflect the most updated plans.

Sent for the following action(s):

- For Approval
 For Distribution
 For Your Use/Files
 As Req'd per

Action Needed:

Sincerely,
Teesa Vassar

Kuck Mechanical Contractors
395 W. 67th St.
Loveland, CO 80538



CFM COMPANY

AIR CONDITIONING / HEATING / VENTILATING EQUIPMENT
413 D North US Highway 287 • Fort Collins, CO 80524
Phone: (970)-493-7293 • Fax: (970)-493-7297



RE-SUBMITTAL DATA

DATE: June 4, 2012

CFM COMPANY ORDER NO: 27120-EL

TO: Kuck Mechanical
Attn: Tom Wasmer
395 West 67th Street
Loveland, CO 80539

PROJECT: Harold D Thompson Pumping & Disinfection Building
LOCATION: Fountain, CO
ARCHITECT:
ENGINEER: GMS, Inc.

SUBMITTAL DATA ON THE FOLLOWING EQUIPMENT

MANUFACTURER	EQUIPMENT	SPECIFICATION SECTION
Greenheck	Inline Centrifugal Fan	15800
Greenheck	Stationary Louvers	15800

Equipment has not been released for production.

Thank you for doing business with CFM Company North, and if you have any questions or concerns, please feel free to contact me.

Eric Larsen

PLEASE RETURN ONE APPROVED SET OF THESE SUBMITTALS TO:
CFM COMPANY NORTH
413D North US Highway 287
Fort Collins, CO 80524

Internal view

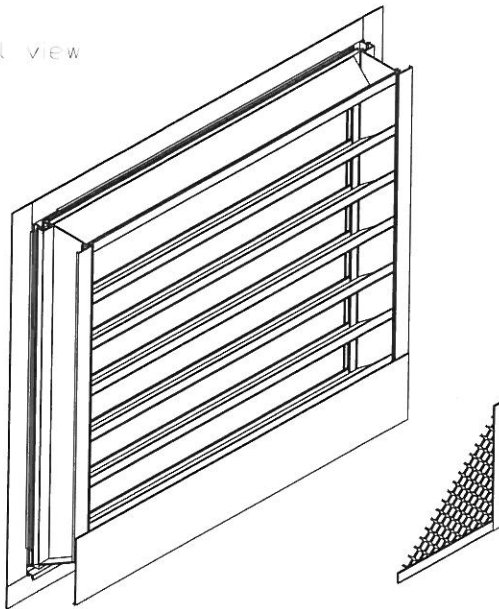

ESD-435
4" Frame, 35° Blade
Application & Design

ESD-435 is a weather louver designed to protect air intake and exhaust openings in building exterior walls. Design incorporates drain gutters in the head member and horizontal blades to channel water to the jambs where water is further channeled through vertical downspouts and out at the sloped sill. The ESD-435 is an extremely efficient louver with AMCA LICENSED PERFORMANCE DATA enabling designers to select and apply with confidence.

Width and Height furnished approximately 0.250 in under size.

Construction Features

Frame Depth (in):	4	Frame Thickness (in):	0.081	Louver Material:	Aluminum
Sizing:	Nominal	Fixed Blade Thick. (in):	0.081		
Shape:	Rectangular				
Frame Type:	Flanged				

Options and Accessories

Finish Type:	Primer	Finish Color:	N/A		
Flange Location:	Exterior	Flange Extension (in):	1.5		
Bird Screen:	Internal	Bird Screen Type:	Flat Expanded	Bird Screen Mat'l:	Aluminum
Bird Screen Finish:	Match Louver				
Welded Construction:	No				

Summary

ID #	Tag	Qty.	W (in)	H (in)	Free Area (ft2)	Sect. Wide	Sect. High	Sect. Ship
17-1		1	24.000	24.000	1.82	1	1	1

Performance

ID #	Application	Volume (CFM)	Press. Drop (in wg)	Free Area Velocity (ft/min)	BPWP (ft/min)
17-1	Exhaust	340	0.005	186	1,151

**Calculated pressure drop does not include the effects of screens, filters or other accessories

Larger openings may require field assembly of multiple louver panels to make up the overall opening size. Individual louver panels are designed to withstand a 25 PSF wind-load (please consult Greenheck if the louvers must withstand higher wind-loads). Design, materials and installation of structural reinforcement required to adequately support large sections or multiple section assemblies within a large opening are not provided by Greenheck. Unless specifically indicated, the following are NOT included in the quote provided: structural steel, installation hardware (anchors, angle clips, continuous angles, shims, fasteners, inserts, backer rod and sealant), field measuring and/or installation, miscellaneous flashing, trim or enclosures, blank off panels, mullion covers or mullion hardware, hinged frames or removable subframes, custom bird/insect screen, 3-coat, metallic and/or exotic paint finishes, bituminous paints for unlike metals, any applicable laxes, stamped and sealed structural calculations or seismic calculations.

AMCA



GreenheckFanCorporation certifies that the louver shown herein is licensed to bear the AMCA Seal. The ratings shown are based on tests and procedures performed in accordance with AMCA Publication 511 and comply with the requirements of the AMCA Certified Ratings Program. The AMCA Certified Ratings Seal applies to air performance and water penetration ratings. The AMCA licensed performance data has been modified for installation, appurtenances, accessories, etc. not included in the certified data. The modified performance is not AMCA licensed but is provided to aid in selection and applications of the air control device.

Internal view

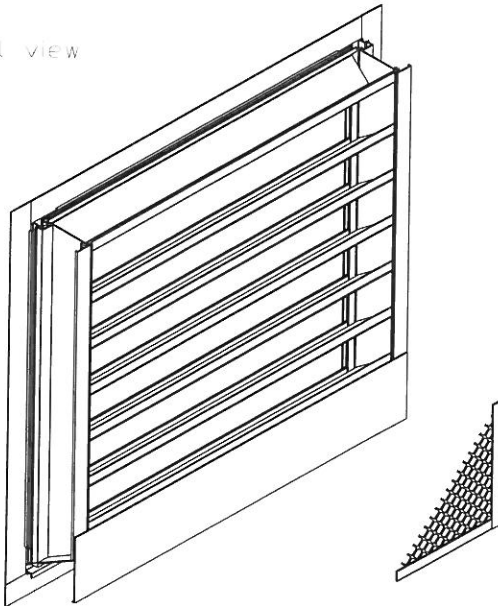

ESD-435
4" Frame, 35° Blade
Application & Design

ESD-435 is a weather louver designed to protect air intake and exhaust openings in building exterior walls. Design incorporates drain gutters in the head member and horizontal blades to channel water to the jams where water is further channeled through vertical downspouts and out at the sloped sill. The ESD-435 is an extremely efficient louver with AMCA LICENSED PERFORMANCE DATA enabling designers to select and apply with confidence.

Width and Height furnished approximately 0.250 in under size.

Construction Features

Frame Depth (in):	4	Frame Thickness (in):	0.081	Louver Material:	Aluminum
Sizing:	Nominal	Fixed Blade Thick. (in):	0.081		
Shape:	Rectangular				
Frame Type:	Flanged				

Options and Accessories

Finish Type:	Primer	Finish Color:	N/A		
Flange Location:	Exterior	Flange Extension (in):	1.5		
Bird Screen:	Internal	Bird Screen Type:	Flat Expanded	Bird Screen Mat'l:	Aluminum
Bird Screen Finish:	Match Louver				
Welded Construction:	No				

Summary

ID #	Tag	Qty.	W (in)	H (in)	Free Area (ft2)	Sect. Wide	Sect. High	Sect. Ship
19-1		1	24.000	24.000	1.82	1	1	1

Performance

ID #	Application	Volume (CFM)	Press. Drop (in wg)	Free Area Velocity (ft/min)	BPWP (ft/min)
19-1	Intake	340	0.006	186	1,151

**Calculated pressure drop does not include the effects of screens, filters or other accessories

Larger openings may require field assembly of multiple louver panels to make up the overall opening size. Individual louver panels are designed to withstand a 25 PSF wind-load (please consult Greenheck if the louvers must withstand higher wind-loads). Design, materials and installation of structural reinforcement required to adequately support large sections or multiple section assemblies within a large opening are not provided by Greenheck. Unless specifically indicated, the following are NOT included in the quote provided: structural steel, installation hardware (anchors, angle clips, continuous angles, shims, fasteners, inserts, backer rod and sealant), field measuring and/or installation, miscellaneous flashing, trim or enclosures, blank off panels, mullion covers or mullion hardware, hinged frames or removable subframes, custom bird/insect screen, 3-coat, metallic and/or exotic paint finishes, bituminous paints for unlike metals, any applicable taxes, stamped and sealed structural calculations or seismic calculations.

AMCA



GreenheckFanCorporation certifies that the louver shown herein is licensed to bear the AMCA Seal. The ratings shown are based on tests and procedures performed in accordance with AMCA Publication 511 and comply with the requirements of the AMCA Certified Ratings Program. The AMCA Certified Ratings Seal applies to air performance and water penetration ratings. The AMCA licensed performance data has been modified for installation, appurtenances, accessories, etc. not included in the certified data. The modified performance is not AMCA licensed but is provided to aid in selection and applications of the air control device.

Stationary Louver Drainable Blade

Application and Design

ESD-435 is a weather louver designed to protect air intake and exhaust openings in building exterior walls. Design incorporates drain gutters in the head member and horizontal blades to channel water to the jambs where water is further channeled through vertical downspouts and out at the sloped sill. The ESD-435 is an extremely efficient louver with **AMCA LICENSED PERFORMANCE DATA** enabling designers to select and apply with confidence.

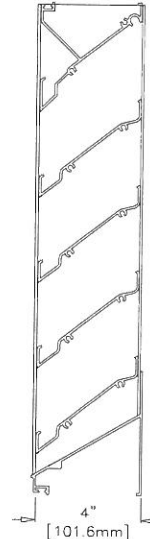

Standard Construction

- Frame** Heavy gauge extruded 6063-T5 aluminum, 4 in. x 0.081 in. nominal wall thickness
- Blades** Drainable design, heavy gauge extruded 6063-T5 aluminum, 0.081 in. nominal wall thickness, positioned at 37.5° angles on approximately 3 1/4 in. centers
- Construction** . . . Mechanically fastened
- Birdscreen** 3/4 in. x 0.051 in. flattened expanded aluminum in removable frame, inside mount (rear)
- Finish** Mill
- Minimum Size** . . 12 in. W x 12 in. H
- Maximum Single Section Size** . . . 120 in. W or 120 in. H (limited to 70 ft. sq.)

Options (at additional cost)

- A variety of bird and insect screens
- Blank off panel
- Clip angles
- Extended sill
- Filter rack
- Flanged frame
- Glazing adaptor
- Hinged frame
- Security bars
- Welded construction
- 0.125 nominal wall thickness
- A variety of architectural finishes including:
 - Clear anodize
 - Integral color anodize
 - Baked enamel paint
 - Kynar paint

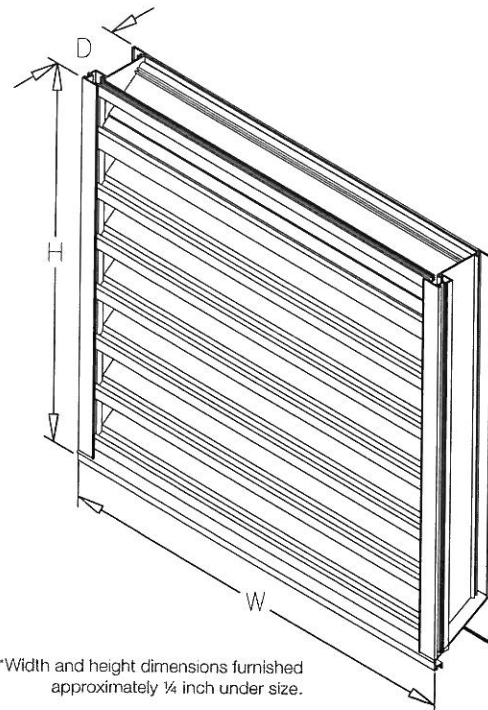

*Width and height dimensions furnished approximately 1/4 inch under size.

PERFORMANCE DATA

ESD-435

Stationary Louver Drainable Blade
Extruded Aluminum

Free Area Chart (Sq. ft.)

Louver Height Inches	Louver Width in Inches												
	12	18	30	36	48	54	66	72	84	90	102	108	120
12	0.29	0.48	0.85	1.04	1.41	1.56	1.93	2.12	2.49	2.68	3.01	3.20	3.57
18	0.54	0.89	1.59	1.94	2.64	2.91	3.61	3.96	4.66	5.01	5.62	5.97	6.67
24	0.79	1.31	2.33	2.85	3.87	4.26	5.29	5.80	6.83	7.24	8.24	8.75	9.78
30	1.05	1.72	3.08	3.76	5.12	5.63	6.98	7.66	9.02	9.70	10.88	11.56	12.92
36	1.30	2.15	3.84	4.69	6.38	7.01	8.70	9.55	11.24	12.09	13.57	14.41	16.10
42	1.56	2.57	4.59	5.60	7.62	8.39	10.40	11.42	13.44	14.45	16.22	17.23	19.25
48	1.84	3.03	5.41	6.60	8.98	9.87	12.25	13.44	15.82	17.01	19.10	20.29	22.67
54	2.10	3.46	6.19	7.55	10.28	11.30	14.03	15.39	18.12	19.48	21.87	23.23	25.98
60	2.35	3.88	6.93	8.46	11.51	12.65	15.71	17.23	20.28	21.81	24.48	26.01	29.06
66	2.61	4.29	7.67	9.36	12.74	14.01	17.39	19.08	22.46	24.15	27.11	28.80	32.19
72	2.86	4.72	8.43	10.29	14.00	15.39	19.11	20.96	24.67	26.53	29.78	31.64	35.35
78	3.12	5.14	9.18	11.20	15.25	16.76	20.81	22.83	26.87	28.89	32.43	34.45	38.50
84	3.38	5.57	9.96	12.15	16.54	18.19	22.57	24.76	29.15	31.34	35.18	37.39	41.76
90	3.66	6.04	10.79	13.16	17.92	19.70	24.45	26.82	31.57	33.95	38.11	40.48	45.23
96	3.91	6.45	11.53	14.07	19.14	21.05	26.13	28.66	33.74	36.28	40.72	43.26	48.34
102	4.17	6.87	12.27	14.97	20.38	22.40	27.81	30.51	35.91	38.61	43.34	46.04	51.45
108	4.42	7.29	13.02	15.89	21.62	23.77	29.50	32.37	38.10	40.97	45.98	48.85	54.58
114	4.68	7.71	13.78	16.81	22.88	25.15	31.22	34.25	40.32	43.36	48.66	51.70	57.77
120	4.93	8.13	14.53	17.73	24.13	26.53	32.92	36.12	42.52	45.72	51.32	54.52	60.91



Greenheck Fan Corporation certifies that the ESD-435 louvers shown herein are licensed to bear the AMCA Seal. The ratings shown are based on tests and procedures performed in accordance with AMCA Publication 511 and comply with the requirements of the AMCA Certified Ratings Program. The AMCA Certified Ratings Seal applies to air performance and water penetration ratings.

Airflow Resistance (Standard Air - .075 lb/ft³)

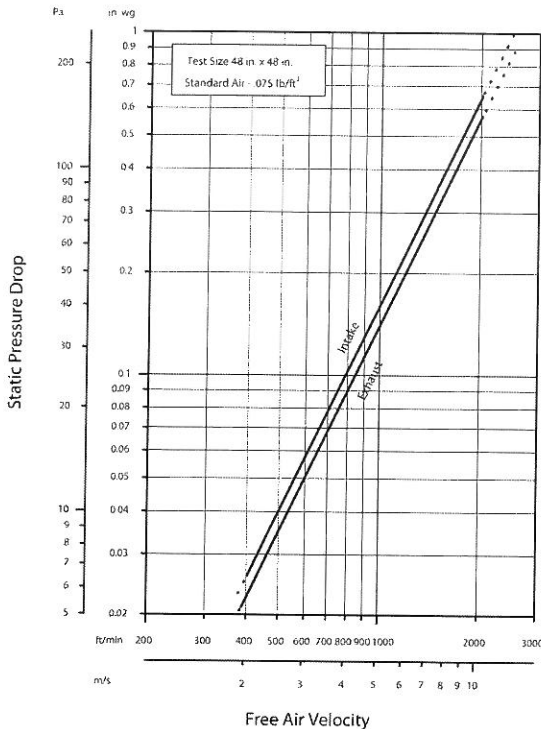

Model ESD-435 resistance to airflow (pressure drop) varies depending on louver application (air intake or air exhaust). Free area velocities (shown) are higher than average velocity through the overall louver size. See louver selection information.

Water Penetration (Standard Air - .075 lb/ft³)

Test size 48 in. x 48 in. Test duration of 15 min.

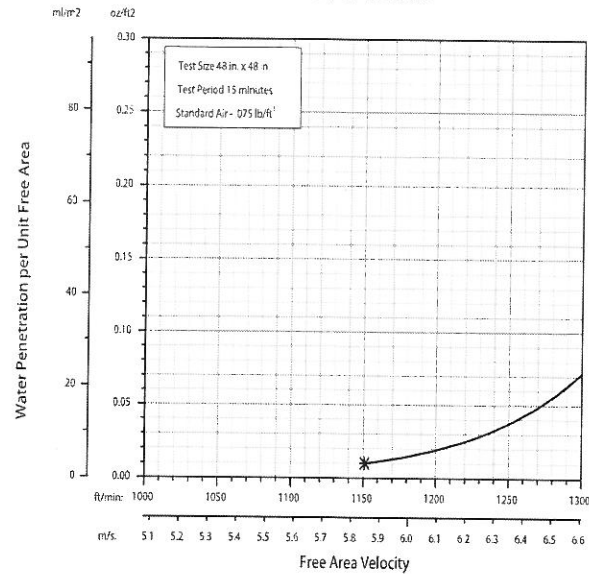

The AMCA Water Penetration Test provides a method for comparing various louver models and designs as to their efficiency in resisting the penetration of rainfall under specific laboratory test conditions. The beginning point of water penetration is defined as that velocity where the water penetration curve projects through .01 oz. of water (penetration) per sq. ft. of louver free area. ***The beginning point of water penetration for Model ESD-435 is 1151 fpm free area velocity.** These performance ratings do not guarantee a louver to be weatherproof or stormproof and should be used in combination with other factors including good engineering judgement in selecting louvers.



INSTALLATION DETAILS

ESD-435

Maximum Size and Installation Information

Stationary Louver Drainable Blade
Extruded Aluminum

Maximum single section size for model ESD-435 is 120 in. W x 84 in. H or 84 in. W x 120 in. H (70 sq. ft). Larger openings require field assembly of multiple louver panels to make up the overall opening size. Individual louver panels are designed to withstand a 25 PSF wind-load (please consult Greenheck if the louvers must withstand higher wind-loads). Structural reinforcing members may be required to adequately support and install multiple louver panels within a large opening. Structural reinforcing members along with any associated installation hardware is not provided by Greenheck unless indicated otherwise by Greenheck. Additional information on louver installation may be found in AMCA Publication #501, Louver Application Manual.

SINGLE SECTION
W/ SUPPORT ANGLES

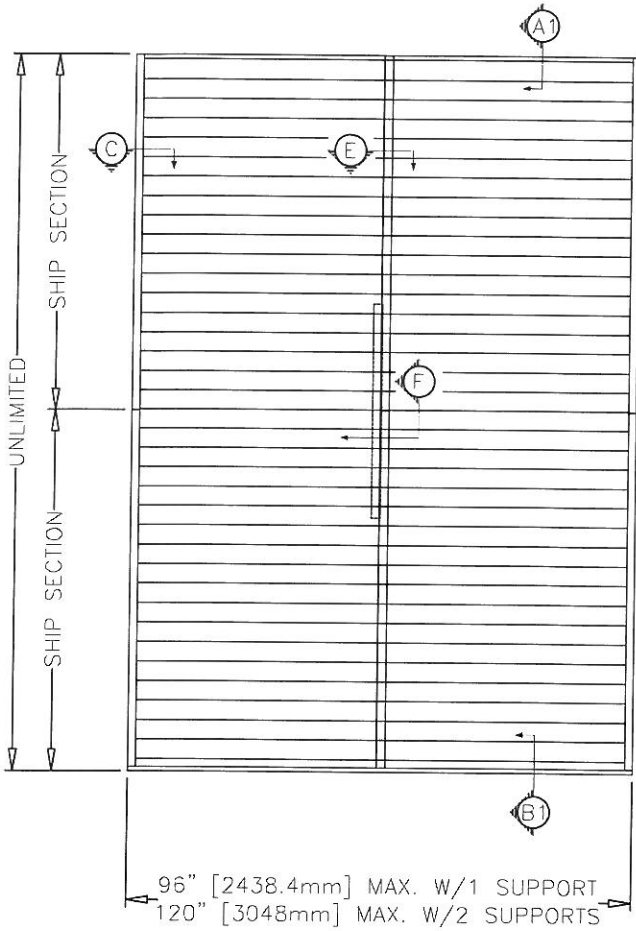

MULTIPLE SECTION W/ MULLION

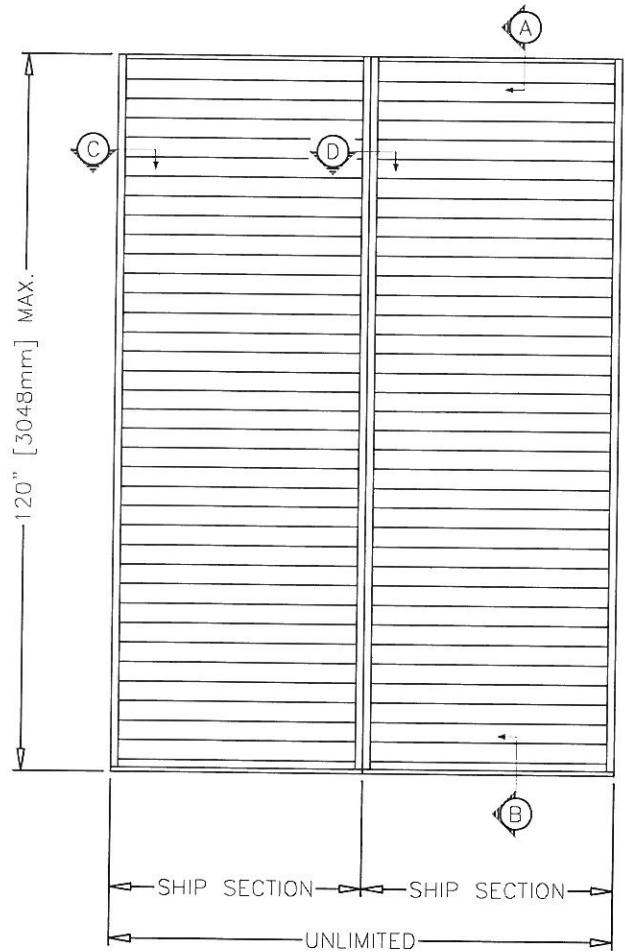

Minimum Single Section Size
12 in. W x 9 in. H

Maximum Single Section Size
70 ft. sq.

PRODUCT DETAILS

ESD-435

Stationary Louver Drainable Blade Extruded Aluminum

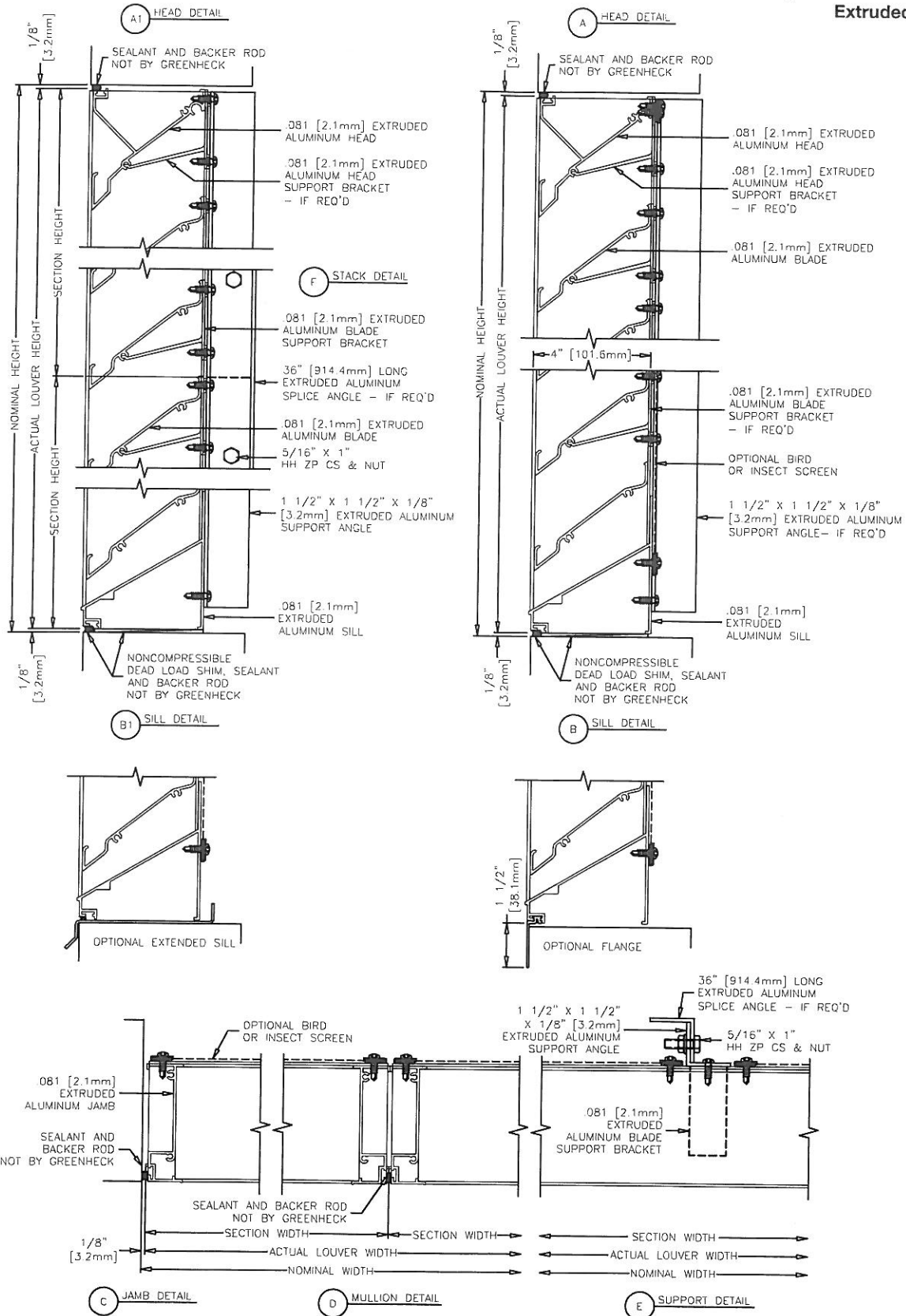

OPTION DRAWINGS

ESD-435

Stationary Louver Drainable Blade
Extruded Aluminum

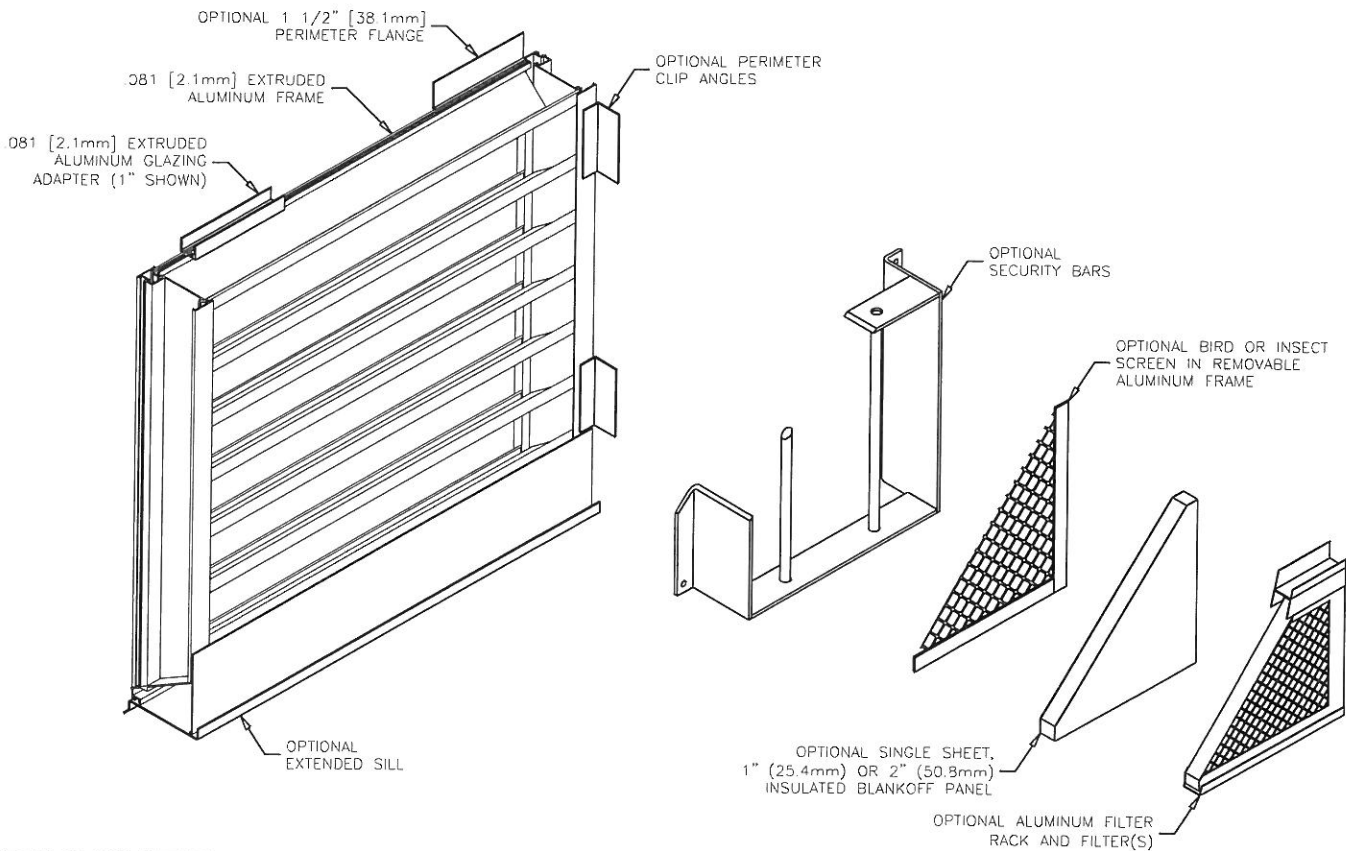

FINISHES

Finish Type	Description/Application	Color Selection	Standard Warranty (Aluminum)
2-coat 70% KYNAR 5000®/HYLAR 5000® AAMA 2605 – Dry film thickness 1.2 mil. (AKA: Duranar®, Fluoropon®, Trinar®, Flouropolymer, Polyvinylidene Fluoride, PVDF2)	“Best.” The premier finish for extruded aluminum. Tough, long-lasting coating has superior color retention and abrasive properties. Resists chalking, fading, chemical abrasion and weathering.	Standard Colors: Any of the 24 standard colors shown can be furnished in 70% or 50% KYNAR 5000®/HYLAR 5000® or Baked Enamel.	10 Years (Consult Greenheck for availability of extended warranty)
2-coat 50% KYNAR 5000®/HYLAR 5000® AAMA 2604 – Dry film thickness 1.2 mil. (AKA: Acroflur®, Acrynar®)	“Better.” Tough, long-lasting coating has excellent color retention and abrasive properties. Resists chalking, fading, chemical abrasion and weathering.	2-Coat Mica: Greenheck offers 9 standard 2-coat Mica colors. Other colors are available. Consult Greenheck for possible extra cost when selecting non-standard colors or special finishes.	5 Years
Baked Enamel AAMA 2603 – Dry film thickness 0.8 mil. (AKA: Acrabond Plus®, Duracron®)	“Good.” Provides good adhesion and resistance to weathering, corrosion and chemical stain.		1 Year
Integral Color Anodize AA-M10C22A42 (>0.7 mil)	“Two-step” anodizing is produced by following the normal anodizing step with a second, colorfast process.	Light, Medium or Dark Bronze; Champagne; Black	5 years
Clear Anodize 215 R-1 AA-M10C22A41 (>0.7 mil)	Clear, colorless and hard oxide aluminum coating that resists weathering and chemical attack.	Clear	5 years
Clear Anodize 204 R-1 AA-M10C22A31 (0.4-0.7 mil)	Clear, colorless and hard oxide aluminum coating that resists weathering and chemical attack.	Clear	1 Year
Industrial coatings	Greenheck offers a number of industrial coatings such as Hi-Pro Polyester, Epoxy, and Permatecor®. Consult a Greenheck Product Specialist for complete color and application information.		Consult Greenheck
Mill	Materials may be supplied in natural aluminum or galvanized steel finish when normal weathering is acceptable and there is no concern for color or color change.		n/a

Finishes meet or exceed AAMA 2605, AAMA 2604, and AAMA 2603 requirements. Please consult www.greenheck.com for complete information on standard and extended paint warranties. Paint finish warranties are not applicable to steel products.



ESD-435
July 2007 Rev. 1
Copyright © 2007 Greenheck Fan Corporation

Greenheck Fan Corporation reserves the right to make product changes without notice.



395 West 67th Street
P.O. Box 388
Loveland, CO 80539-0388
Phone: (970) 461-3553
Fax: (970) 461-3443

DATE: 05/01/12

SENT TO: CFM Company
413 N US HWY 287
Fort Collins, CO 80524

Attn: Eric Larsen

JOB: Harold D. Thompson WRF (#01135)
9001 Birdsall Rd.
Fountain, CO 80817

SUBMITTAL NO.: 00021

SUBMITTAL DUE:

PACKAGE: n/a

VENDOR NAME: CFM

SPECIFICATION #: 15800

SUBJECT: P&D Bldg. - Louvers

REVIEW DETAILS:

Review #: 1	Received: 04/13/12	Priority: Normal
Desc: P&D Bldg. - Louvers	Sent: 05/01/12	Status: Approved w/ Note
Reviewer: John Jacob	Returned: 05/25/12	Sepias: 0
Weaver General Contractors	Forwarded: 05/30/12	Prints: 0

Sent for the following action(s):

- For Approval
 For Distribution
 For Your Use/Files
 As Req'd per

Action Needed:

Sincerely,
Teesa Vassar

Kuck Mechanical Contractors
395 W. 67th St.
Loveland, CO 80538

GMS, INC.
CONSULTING ENGINEERS
611 NORTH WEBER, SUITE 300
COLORADO SPRINGS, COLORADO 80903-1074

TELEPHONE (719) 475-2935
TELEFAX (719) 475-2938

EDWARD D. MEYER, P.E.
ROGER J. SAMS, P.E.
GREGORY R. WORDEN, P.E.
THOMAS A. McCLENNAN, P.E.

KEN L. WHITE, P.L.S.
DAVID R. FRISCH, P.L.S.
MARK A. MORTON, P.E.
JASON D. MEYER, P.E.

May 25, 2012

Mr. Wes Weaver, President
Weaver Construction Management, Inc.
3679 South Huron Street, Suite 404
Englewood, CO 80110

Via Email to: wes@weavercm.com
No Hard Copy to Follow

Re: Harold D. Thompson Regional Water Reclamation Facility (HDTRWRF)
Lower Fountain Metropolitan Sewage Disposal District (LFMSDD)

Dear Wes:

Reference is made to your shop submittal identified as follows:

Submittal No.:	15800-014
Date of Submittal:	May 1, 2012
Title:	Combination and Stationary Louvers (L-1 thru L-7) at P&D Building
Specification Section:	15800 – Heating and Ventilating
Manufacturer:	Greenheck Fan Corporation

The referenced submittal has been stamped "***Make Corrections Noted***". Our comments are as follows:

1. Revise Louvers L-6 and L-7 to be in accordance with the louver schedule shown on the "Issued for Construction" drawings dated May 21, 2012.

Please call if you should have any questions.

Sincerely,



David R. Frisch, P.L.S.

DRF/kmw

ec (letter only):

Mr. Jim Heckman, Manager, LFMSDD, lfmanager@lfmsdd.org
Ms. Cindy Murray, Office Manager, Fountain Sanitation District, fsdistrict@fsd901.org
Mr. Jeff Burst, Project Supt., Weaver Construction Management, Inc., jeff@weavercm.com
Mr. John Jacob, Project Mgr., Weaver Construction Management, Inc., john@weavercm.com
Mr. Tyler Ammerman, Weaver Construction Management, Inc., tammerman@weavercm.com
Ms. Leslie Brown, Weaver Construction Management, Inc., leslie@weavercm.com

cc: Mr. Jerry Miller, Resident Project Representative, GMS, Inc.



395 West 67th Street
P.O. Box 388
Loveland, CO 80539-0388
Phone: (970) 461-3553
Fax: (970) 461-3443

DATE: 05/01/12
SENT TO: Weaver General Contractors
Attn: John Jacob
JOB: Harold D. Thompson WRF (#01135)
9001 Birdsell Rd.
Fountain, CO 80817

SUBMITTAL NO.: 00021
SUBMITTAL DUE:
PACKAGE: n/a

VENDOR NAME: CFM
SUBJECT: P&D Bldg. - Louvers
SPECIFICATION #: 15800

REVIEW DETAILS:

Review #: 1	Received: 04/13/12	Priority: Normal
Desc: P&D Bldg. - Louvers	Sent: 05/01/12	Status: Open
Reviewer: John Jacob	Returned:	Sepias: 0
Weaver General Contractors	Forwarded:	Prints: 0

Sent for the following action(s):

- For Approval**

 For Distribution

 For Your Use/Files

 As Req'd per

Action Needed:

Sincerely,
Teesa Vassar

Kuck Mechanical Contractors
395 W. 67th St.
Loveland, CO 80538



CFM COMPANY

AIR CONDITIONING / HEATING / VENTILATING EQUIPMENT
413 D North US Highway 287 • Fort Collins, CO 80524
Phone: (970)-493-7293 • Fax: (970)-493-7297



SUBMITTAL DATA

DATE: March 16, 2012

CFM COMPANY ORDER NO: 27120-EL

TO: Kuck Mechanical
Attn: Tom Wasmer
395 West 67th Street
Loveland, CO 80539

PROJECT: Harold D Thompson Pumping & Disinfection Building
LOCATION: Fountain, CO
ARCHITECT:
ENGINEER: GMS, Inc.

SUBMITTAL DATA ON THE FOLLOWING EQUIPMENT

MANUFACTURER	EQUIPMENT	SPECIFICATION SECTION
Indeco	Electric Heater	
Cerus	Magnetic Starter	15058
Greenheck	Sidewall Prop Fans	15800
Greenheck	Inline Centrifugal Fan	15800
Greenheck	Combination Louvers	15800
Greenheck	Stationary Louvers	15800

Equipment has not been released for production.

Thank you for doing business with CFM Company North, and if you have any questions or concerns, please feel free to contact me.

Eric Larsen

PLEASE RETURN ONE APPROVED SET OF THESE SUBMITTALS TO:
CFM COMPANY NORTH
413D North US Highway 287
Fort Collins, CO 80524

Internal view

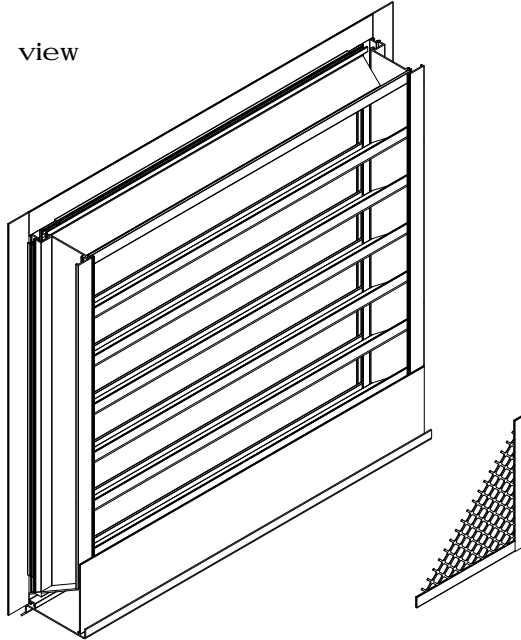

ESD-435
4" Frame, 35° Blade
Application & Design

ESD-435 is a weather louver designed to protect air intake and exhaust openings in building exterior walls. Design incorporates drain gutters in the head member and horizontal blades to channel water to the jambs where water is further channeled through vertical downspouts and out at the sloped sill. The ESD-435 is an extremely efficient louver with AMCA LICENSED PERFORMANCE DATA enabling designers to select and apply with confidence.

Width and Height furnished approximately 0.250 in under size.

Construction Features

Frame Depth (in):	4	Frame Thickness (in):	0.081	Louver Material:	Aluminum
Sizing:	Nominal	Fixed Blade Thick. (in):	0.081		
Shape:	Rectangular				
Frame Type:	Flanged				

Options and Accessories

Finish Type:	Primer	Finish Color:	N/A		
Flange Location:	Exterior	Flange Extension (in):	1.5		
Extended Sill:	Aluminum	Sill Depth (in):	4.500		
Bird Screen:	Internal	Bird Screen Type:	Mesh	Bird Screen Mat'l:	Aluminum
Bird Screen Finish:	Match Louver				
Welded Construction:	No				

Summary

ID #	Tag	Qty.	W (in)	H (in)	Free Area (ft2)	Sect. Wide	Sect. High	Sect. Ship
2-1		1	38.000	18.000	2.07	1	1	1

Performance

ID #	Application	Volume (CFM)	Press. Drop (in wg)	Free Area Velocity (ft/min)	BPWP (ft/min)
2-1	Exhaust	880	0.025	425	1,151

**Calculated pressure drop does not include the effects of screens, filters or other accessories

Larger openings may require field assembly of multiple louver panels to make up the overall opening size. Individual louver panels are designed to withstand a 25 PSF wind-load (please consult Greenheck if the louvers must withstand higher wind-loads). Design, materials and installation of structural reinforcement required to adequately support large sections or multiple section assemblies within a large opening are not provided by Greenheck. Unless specifically indicated, the following are NOT included in the quote provided: structural steel, installation hardware (anchors, angle clips, continuous angles, shims, fasteners, inserts, backer rod and sealant), field measuring and/or installation, miscellaneous flashing, trim or enclosures, blank off panels, mullion covers or mullion hardware, hinged frames or removable subframes, custom bird/insect screen, 3-coat, metallic and/or exotic paint finishes, bituminous paints for unlike metals, any applicable taxes, stamped and sealed structural calculations or seismic calculations.

AMCA



GreenheckFanCorporation certifies that the louver shown herein is licensed to bear the AMCA Seal. The ratings shown are based on tests and procedures performed in accordance with AMCA Publication 511 and comply with the requirements of the AMCA Certified Ratings Program. The AMCA Certified Ratings Seal applies to air performance and water penetration ratings. The AMCA licensed performance data has been modified for installation, appurtenances, accessories, etc. not included in the certified data. The modified performance is not AMCA licensed but is provided to aid in selection and applications of the air control device.

Internal view

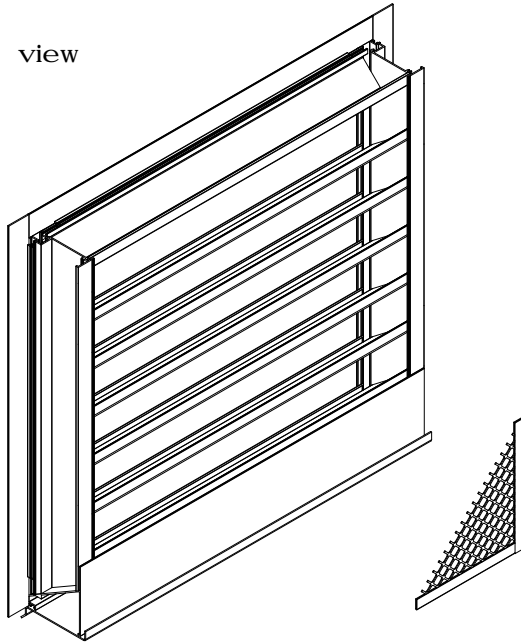

ESD-435
4" Frame, 35° Blade
Application & Design

ESD-435 is a weather louver designed to protect air intake and exhaust openings in building exterior walls. Design incorporates drain gutters in the head member and horizontal blades to channel water to the jambs where water is further channeled through vertical downspouts and out at the sloped sill. The ESD-435 is an extremely efficient louver with AMCA LICENSED PERFORMANCE DATA enabling designers to select and apply with confidence.

Width and Height furnished approximately 0.250 in under size.

Construction Features

Frame Depth (in):	4	Frame Thickness (in):	0.081	Louver Material:	Aluminum
Sizing:	Nominal	Fixed Blade Thick. (in):	0.081		
Shape:	Rectangular				
Frame Type:	Flanged				

Options and Accessories

Finish Type:	Primer	Finish Color:	N/A		
Flange Location:	Exterior	Flange Extension (in):	1.5		
Extended Sill:	Aluminum	Sill Depth (in):	4.500		
Bird Screen:	Internal	Bird Screen Type:	Mesh	Bird Screen Mat'l:	Aluminum
Bird Screen Finish:	Match Louver				
Welded Construction:	No				

Summary

ID #	Tag	Qty.	W (in)	H (in)	Free Area (ft2)	Sect. Wide	Sect. High	Sect. Ship
3-1		1	38.000	18.000	2.07	1	1	1

Performance

ID #	Application	Volume (CFM)	Press. Drop (in wg)	Free Area Velocity (ft/min)	BPWP (ft/min)
3-1	Intake	880	0.029	425	1,151

**Calculated pressure drop does not include the effects of screens, filters or other accessories

Larger openings may require field assembly of multiple louver panels to make up the overall opening size. Individual louver panels are designed to withstand a 25 PSF wind-load (please consult Greenheck if the louvers must withstand higher wind-loads). Design, materials and installation of structural reinforcement required to adequately support large sections or multiple section assemblies within a large opening are not provided by Greenheck. Unless specifically indicated, the following are NOT included in the quote provided: structural steel, installation hardware (anchors, angle clips, continuous angles, shims, fasteners, inserts, backer rod and sealant), field measuring and/or installation, miscellaneous flashing, trim or enclosures, blank off panels, mullion covers or mullion hardware, hinged frames or removable subframes, custom bird/insect screen, 3-coat, metallic and/or exotic paint finishes, bituminous paints for unlike metals, any applicable taxes, stamped and sealed structural calculations or seismic calculations.

AMCA



GreenheckFanCorporation certifies that the louver shown herein is licensed to bear the AMCA Seal. The ratings shown are based on tests and procedures performed in accordance with AMCA Publication 511 and comply with the requirements of the AMCA Certified Ratings Program. The AMCA Certified Ratings Seal applies to air performance and water penetration ratings. The AMCA licensed performance data has been modified for installation, appurtenances, accessories, etc. not included in the certified data. The modified performance is not AMCA licensed but is provided to aid in selection and applications of the air control device.

Stationary Louver Drainable Blade

Application and Design

ESD-435 is a weather louver designed to protect air intake and exhaust openings in building exterior walls. Design incorporates drain gutters in the head member and horizontal blades to channel water to the jambs where water is further channeled through vertical downspouts and out at the sloped sill. The ESD-435 is an extremely efficient louver with **AMCA LICENSED PERFORMANCE DATA** enabling designers to select and apply with confidence.

Standard Construction

- Frame** Heavy gauge extruded 6063-T5 aluminum, 4 in. x 0.081 in. nominal wall thickness
- Blades** Drainable design, heavy gauge extruded 6063-T5 aluminum, 0.081 in. nominal wall thickness, positioned at 37.5° angles on approximately 3 ¼ in. centers
- Construction** . . . Mechanically fastened
- Birdscreen** 3/4 in. x 0.051 in. flattened expanded aluminum in removable frame, inside mount (rear)
- Finish** Mill
- Minimum Size** . . 12 in. W x 12 in. H
- Maximum Single Section Size** . . 120 in. W or 120 in. H (limited to 70 ft. sq.)

Options (at additional cost)

- A variety of bird and insect screens
- Blank off panel
- Clip angles
- Extended sill
- Filter rack
- Flanged frame
- Glazing adaptor
- Hinged frame
- Security bars
- Welded construction
- 0.125 nominal wall thickness
- A variety of architectural finishes including:
 - Clear anodize
 - Integral color anodize
 - Baked enamel paint
 - Kynar paint

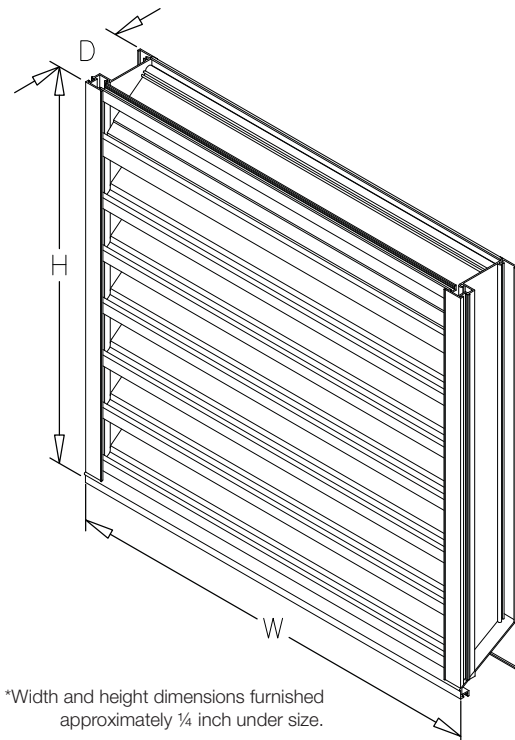
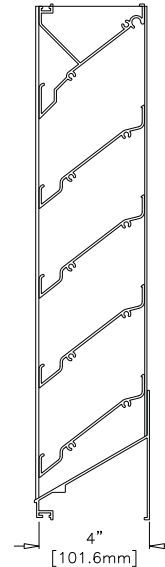

*Width and height dimensions furnished approximately ¼ inch under size.

PERFORMANCE DATA

ESD-435

Stationary Louver Drainable Blade
Extruded Aluminum

Free Area Chart (Sq. ft.)

Louver Height Inches	Louver Width in Inches												
	12	18	30	36	48	54	66	72	84	90	102	108	120
12	0.29	0.48	0.85	1.04	1.41	1.56	1.93	2.12	2.49	2.68	3.01	3.20	3.57
18	0.54	0.89	1.59	1.94	2.64	2.91	3.61	3.96	4.66	5.01	5.62	5.97	6.67
24	0.79	1.31	2.33	2.85	3.87	4.26	5.29	5.80	6.83	7.34	8.24	8.75	9.78
30	1.05	1.72	3.08	3.76	5.12	5.63	6.98	7.66	9.02	9.70	10.88	11.56	12.92
36	1.30	2.15	3.84	4.69	6.38	7.01	8.70	9.55	11.24	12.09	13.57	14.41	16.10
42	1.56	2.57	4.59	5.60	7.62	8.38	10.40	11.42	13.44	14.45	16.22	17.23	19.25
48	1.84	3.03	5.41	6.60	8.98	9.87	12.25	13.44	15.82	17.01	19.10	20.29	22.67
54	2.10	3.46	6.19	7.55	10.28	11.30	14.03	15.39	18.12	19.48	21.87	23.23	25.96
60	2.35	3.88	6.93	8.46	11.51	12.65	15.71	17.23	20.28	21.81	24.48	26.01	29.06
66	2.61	4.29	7.67	9.36	12.74	14.01	17.39	19.08	22.46	24.15	27.11	28.80	32.18
72	2.86	4.72	8.43	10.29	14.00	15.39	19.11	20.96	24.67	26.53	29.78	31.64	35.35
78	3.12	5.14	9.18	11.20	15.25	16.76	20.81	22.83	26.87	28.89	32.43	34.45	38.50
84	3.38	5.57	9.96	12.15	16.54	18.19	22.57	24.76	29.15	31.34	35.18	37.38	41.76
90	3.66	6.04	10.79	13.16	17.92	19.70	24.45	26.82	31.57	33.95	38.11	40.48	45.23
96	3.91	6.45	11.53	14.07	19.14	21.05	26.13	28.66	33.74	36.28	40.72	43.26	48.34
102	4.17	6.87	12.27	14.97	20.38	22.40	27.81	30.51	35.91	38.61	43.34	46.04	51.45
108	4.42	7.29	13.02	15.89	21.62	23.77	29.50	32.37	38.10	40.97	45.98	48.85	54.58
114	4.68	7.71	13.78	16.81	22.88	25.15	31.22	34.25	40.32	43.36	48.66	51.70	57.77
120	4.93	8.13	14.53	17.73	24.13	26.53	32.92	36.12	42.52	45.72	51.32	54.52	60.91



Greenheck Fan Corporation certifies that the ESD-435 louvers shown herein are licensed to bear the AMCA Seal. The ratings shown are based on tests and procedures performed in accordance with AMCA Publication 511 and comply with the requirements of the AMCA Certified Ratings Program. The AMCA Certified Ratings Seal applies to air performance and water penetration ratings.

Airflow Resistance (Standard Air - .075 lb/ft³)

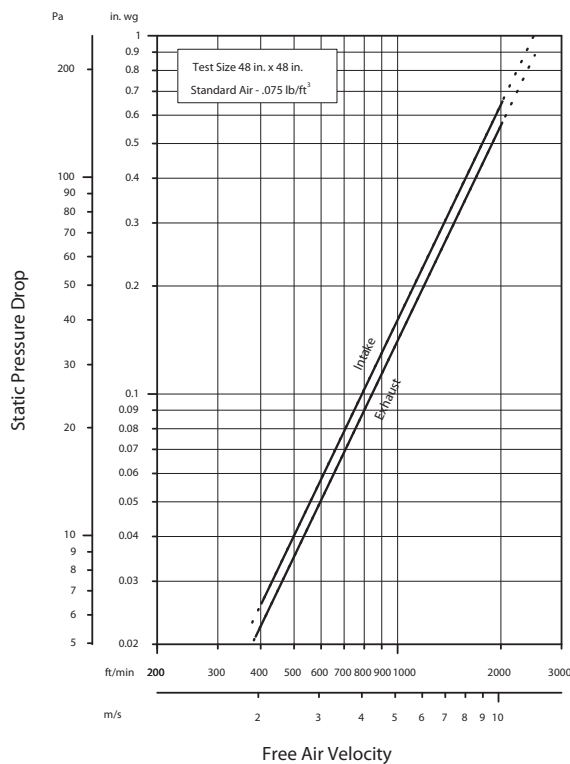

Model ESD-435 resistance to airflow (pressure drop) varies depending on louver application (air intake or air exhaust). Free area velocities (shown) are higher than average velocity through the overall louver size. See louver selection information.

Water Penetration (Standard Air - .075 lb/ft³)

Test size 48 in. x 48 in. Test duration of 15 min.

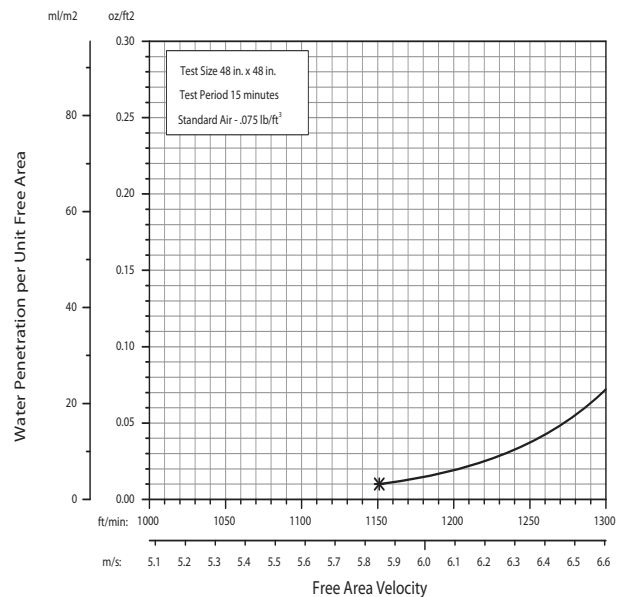

The AMCA Water Penetration Test provides a method for comparing various louver models and designs as to their efficiency in resisting the penetration of rainfall under specific laboratory test conditions. The beginning point of water penetration is defined as that velocity where the water penetration curve projects through .01 oz. of water (penetration) per sq. ft. of louver free area. ***The beginning point of water penetration for Model ESD-435 is 1151 fpm free area velocity.** These performance ratings do not guarantee a louver to be weatherproof or stormproof and should be used in combination with other factors including good engineering judgement in selecting louvers.



INSTALLATION DETAILS

ESD-435

Maximum Size and Installation Information

Stationary Louver Drainable Blade
Extruded Aluminum

Maximum single section size for model ESD-435 is 120 in. W x 84 in. H or 84 in. W x 120 in. H (70 sq. ft). Larger openings require field assembly of multiple louver panels to make up the overall opening size. Individual louver panels are designed to withstand a 25 PSF wind-load (please consult Greenheck if the louvers must withstand higher wind-loads). Structural reinforcing members may be required to adequately support and install multiple louver panels within a large opening. Structural reinforcing members along with any associated installation hardware is not provided by Greenheck unless indicated otherwise by Greenheck. Additional information on louver installation may be found in AMCA Publication #501, Louver Application Manual.

SINGLE SECTION
W/ SUPPORT ANGLES

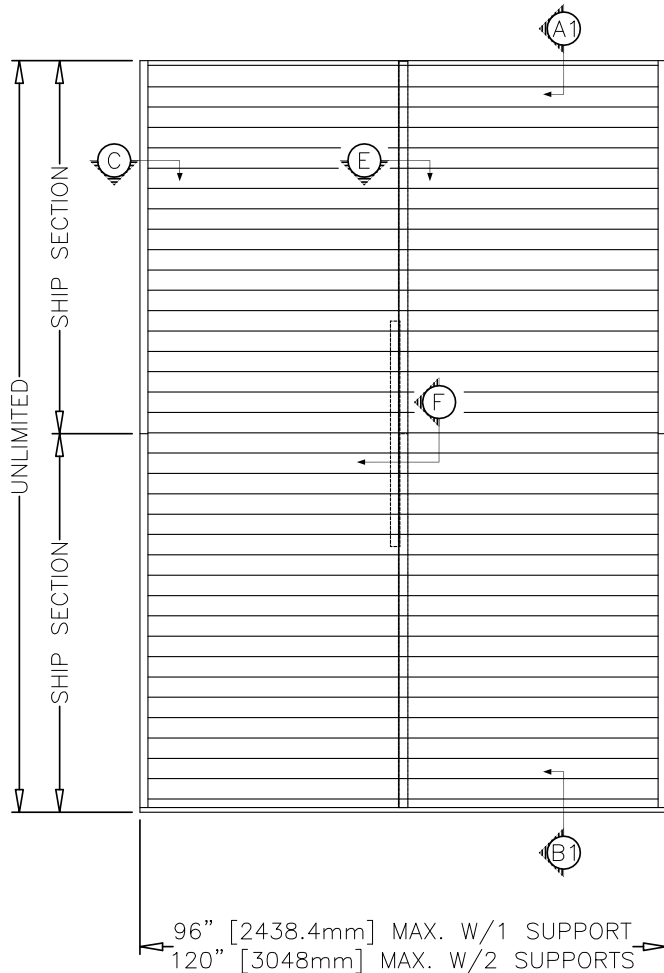

MULTIPLE SECTION W/ MULLION

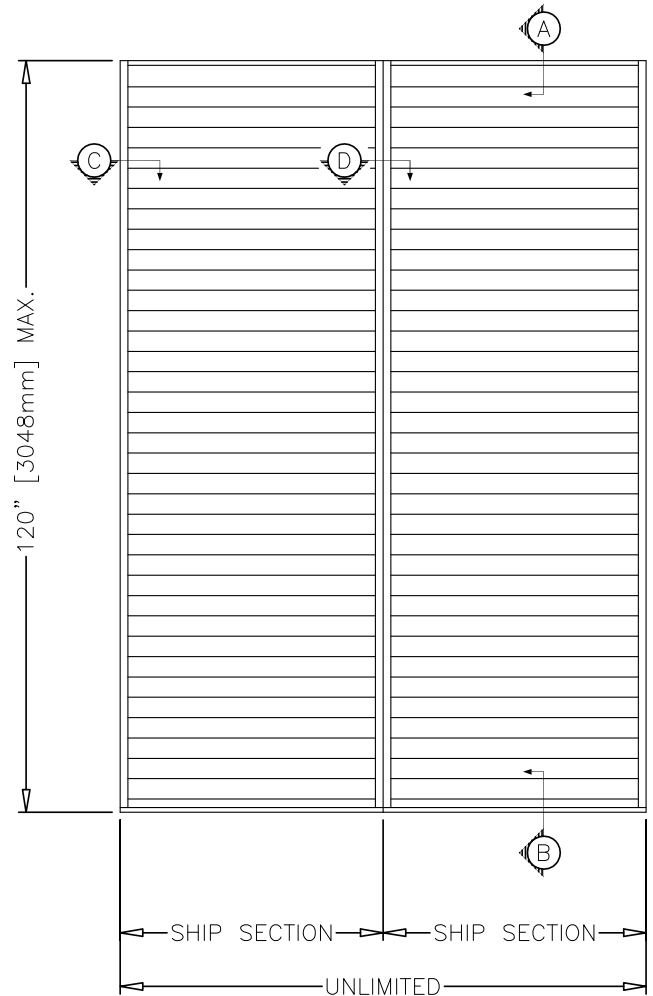

Minimum Single Section Size
12 in. W x 9 in. H

Maximum Single Section Size
70 ft. sq.

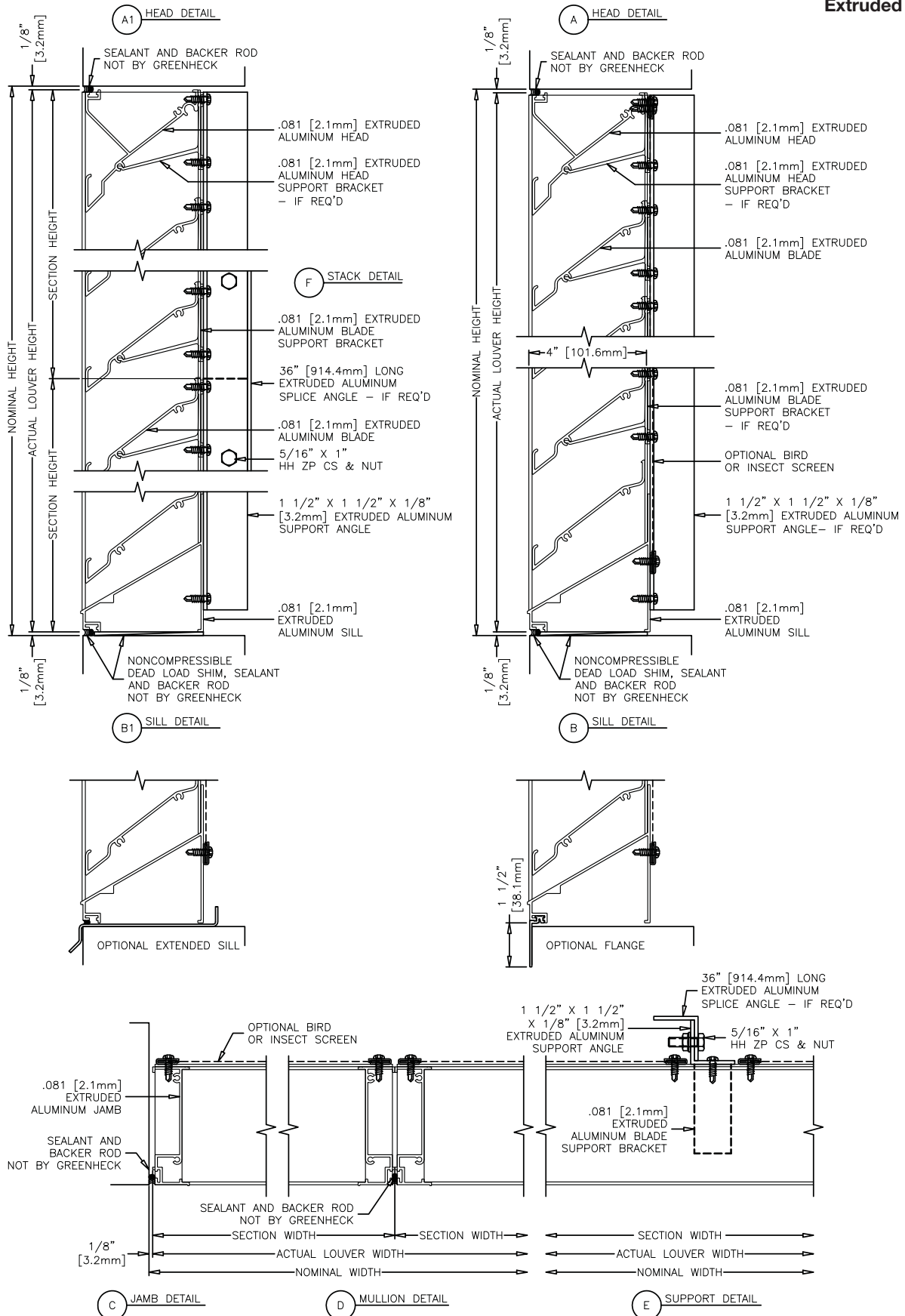

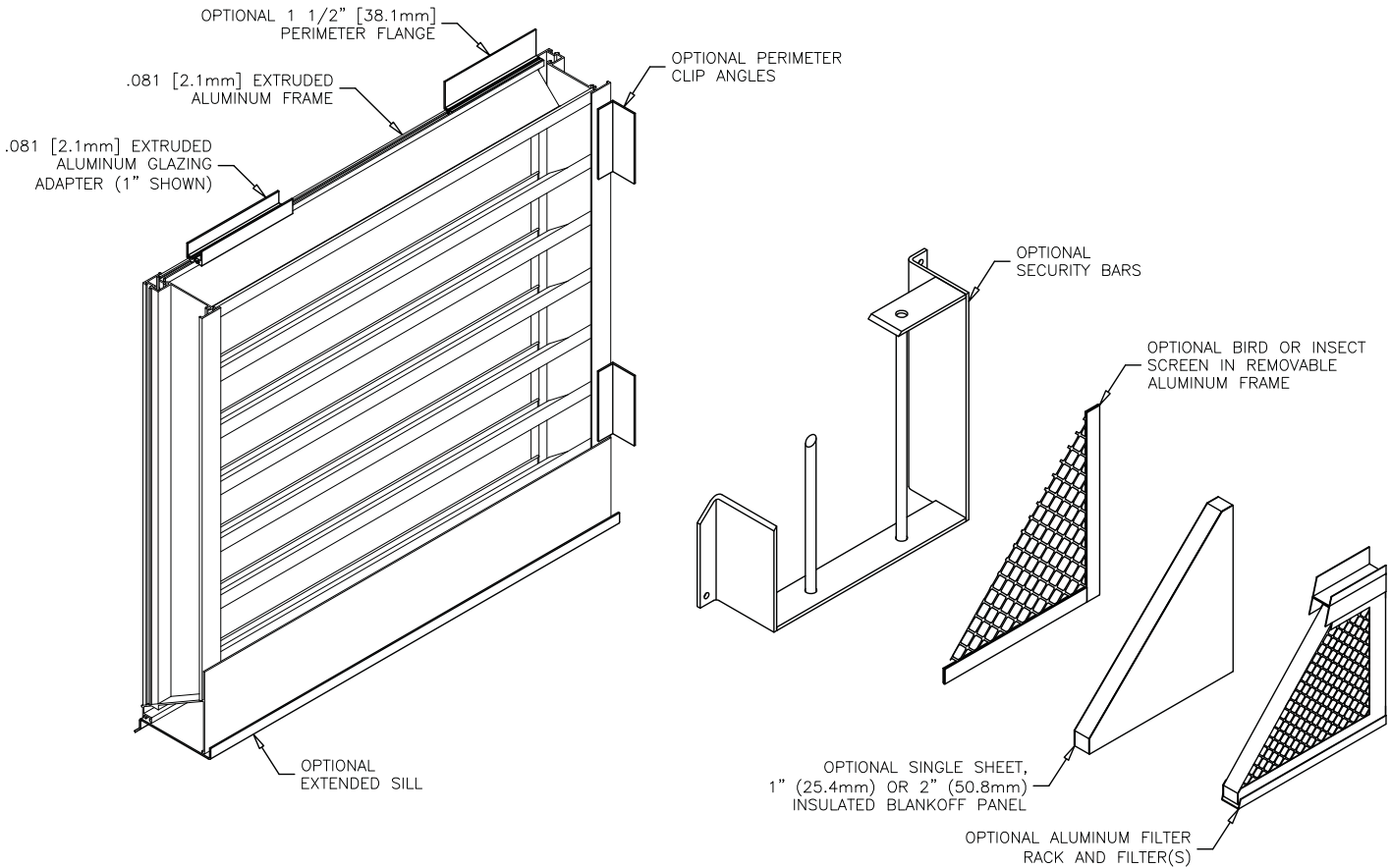

FINISHES

Finish Type	Description/Application	Color Selection	Standard Warranty (Aluminum)
2-coat 70% KYNAR 5000®/HYLAR 5000® AAMA 2605 – Dry film thickness 1.2 mil. (AKA: Duranar®, Fluoropon®, Trinar®, Fluoropolymer, Polyvinylidene Fluoride, PVDF2)	“Best.” The premier finish for extruded aluminum. Tough, long-lasting coating has superior color retention and abrasive properties. Resists chalking, fading, chemical abrasion and weathering.	Standard Colors: Any of the 24 standard colors shown can be furnished in 70% or 50% KYNAR 5000®/HYLAR 5000® or Baked Enamel. 2-Coat Mica: Greenheck offers 9 standard 2-coat Mica colors. Other colors are available. Consult Greenheck for possible extra cost when selecting non-standard colors or special finishes.	10 Years (Consult Greenheck for availability of extended warranty)
2-coat 50% KYNAR 5000®/HYLAR 5000® AAMA 2604 – Dry film thickness 1.2 mil. (AKA: Acroflur®, Acrynar®)	“Better.” Tough, long-lasting coating has excellent color retention and abrasive properties. Resists chalking, fading, chemical abrasion and weathering.		5 Years
Baked Enamel AAMA 2603 – Dry film thickness 0.8 mil. (AKA: Acrabond Plus®, Duracron®)	“Good.” Provides good adhesion and resistance to weathering, corrosion and chemical stain.		1 Year
Integral Color Anodize AA-M10C22A42 (>0.7 mil)	“Two-step” anodizing is produced by following the normal anodizing step with a second, colorfast process.	Light, Medium or Dark Bronze; Champagne; Black	5 years
Clear Anodize 215 R-1 AA-M10C22A41 (>0.7 mil)	Clear, colorless and hard oxide aluminum coating that resists weathering and chemical attack.	Clear	5 years
Clear Anodize 204 R-1 AA-M10C22A31 (0.4-0.7 mil)	Clear, colorless and hard oxide aluminum coating that resists weathering and chemical attack.	Clear	1 Year
Industrial coatings	Greenheck offers a number of industrial coatings such as Hi-Pro Polyester, Epoxy, and Permatector®. Consult a Greenheck Product Specialist for complete color and application information.		Consult Greenheck
Mill	Materials may be supplied in natural aluminum or galvanized steel finish when normal weathering is acceptable and there is no concern for color or color change.		n/a

Finishes meet or exceed AAMA 2605, AAMA 2604, and AAMA 2603 requirements. Please consult www.greenheck.com for complete information on standard and extended paint warranties. Paint finish warranties are not applicable to steel products.



ESD-435

July 2007 Rev. 1

Copyright © 2007 Greenheck Fan Corporation

Greenheck Fan Corporation reserves the right to make product changes without notice.

Internal view

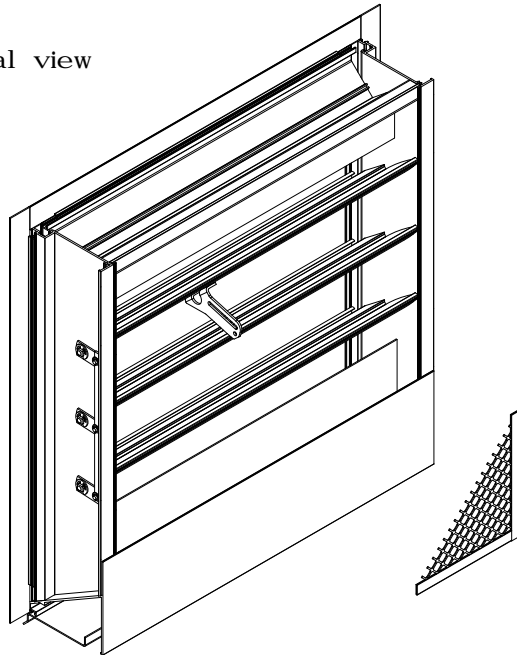

EACA-601

Application & Design

EACA-601 is a combination louver/damper designed to protect air intake and exhaust openings in building exterior walls that, at times, require tight air shut off. Design incorporates a drainable head member, drainable stationary blades and operable airfoil blades. When the operable blades are open, airflow is permitted through the louver, when the blades are closed, a tight seal is created to prevent the passage of air. The EACA-601 is an extremely efficient louver with AMCA LICENSED PERFORMANCE DATA enabling designers to select and apply with confidence.

Width and Height furnished approximately 0.250 in under size.

Construction Features

Frame Depth (in):	6	Frame Thickness (in):	0.125	Louver Material:	Aluminum
Sizing:	Nominal	Fixed Blade Thick. (in):	N/A	Adj. Blade Thick. (in):	0.063
Blade/Jamb Seals:	Yes	Axle Bearings:	Synthetic	Axle Material:	Steel
Actuator Type:	120 VAC	Actuator Mount.:	Internal	Actuator Location:	Left
Actuator Fail. Pos.:	Closed	Act. Operating Mode:	Two Position	Transformer:	None
NEMA Enclosure:	3	Act. Access:	Internal		
Frame Type:	Flanged				

Options and Accessories

Finish Type:	Primer	Finish Color:	N/A		
Flange Location:	Exterior	Flange Extension (in):	1.5		
Extended Sill:	Aluminum	Sill Depth (in):	5.000		
Bird Screen:	Internal	Bird Screen Type:	Mesh	Bird Screen Mat'l:	Aluminum
Bird Screen Finish:	Mill				

Summary

ID #	Tag	Qty.	W (in)	H (in)	Free Area (ft2)	Drive.	Actuator Model	Sect. Wide	Sect. High	Sect. Ship	Actuators/Ship Section
1-1		5	52.000	52.000	9.32	11-1FIL-0	MS4120F1204	1	1	5	1

Performance

ID #	Application	Volume (CFM)	Press. Drop (in wg)	Free Area Velocity (ft/min)	BPWP (ft/min)
1-1	Intake	4,200	0.023	451	1,221

**Calculated pressure drop does not include the effects of screens, filters or other accessories

Larger openings may require field assembly of multiple louver panels to make up the overall opening size. Individual louver panels are designed to withstand a 25 PSF wind-load (please consult Greenheck if the louvers must withstand higher wind-loads). Design, materials and installation of structural reinforcement required to adequately support large sections or multiple section assemblies within a large opening are not provided by Greenheck. Unless specifically indicated, the following are NOT included in the quote provided: structural steel, installation hardware (anchors, angle clips, continuous angles, shims, fasteners, inserts, backer rod and sealant), field measuring and/or installation, miscellaneous flashing, trim or enclosures, blank off panels, mullion covers or mullion hardware, hinged frames or removable subframes, custom bird/insect screen, 3-coat, metallic and/or exotic paint finishes, bituminous paints for unlike metals, any applicable taxes, stamped and sealed structural calculations or seismic calculations.

AMCA



GreenheckFanCorporation certifies that the louver shown herein is licensed to bear the AMCA Seal. The ratings shown are based on tests and procedures performed in accordance with AMCA Publication 511 and comply with the requirements of the AMCA Certified Ratings Program. The AMCA Certified Ratings Seal applies to air performance and water penetration ratings. The AMCA licensed performance data has been modified for installation, appurtenances, accessories, etc. not included in the certified data. The modified performance is not AMCA licensed but is provided to aid in selection and applications of the air control device.

Combination Louver/Damper Airfoil Blade

Application and Design

EACA-601 is a combination louver/damper designed to protect air intake and exhaust openings in building exterior walls that, at times, require tight air shut off. Design incorporates a drainable head member, drainable stationary blades and operable airfoil blades. When the operable blades are open, airflow is permitted through the louver, when the blades are closed, a tight seal is created to prevent the passage of air. The EACA-601 is an extremely efficient louver with **AMCA LICENSED PERFORMANCE DATA** enabling designers to select and apply with confidence.

Standard Construction

- Frame** Heavy gauge extruded 6063-T5 aluminum, 6 in. x 0.125 in. nominal wall thickness
- Blades** Stationary blade: drainable design, heavy gauge extruded 6063-T5 aluminum, 0.081 in. nominal wall thickness, positioned at 45° angles on approximately 5 in. centers
Operable blade: airfoil design, heavy gauge extruded 6063-T5 aluminum, 0.063 nominal wall thickness
- Seals** TPE blade seals
Compressible stainless steel jamb seals
- Temperature Restrictions** . . . (-20° F) - (+180° F)
- Linkage** Side linkage, out of airstream (concealed in frame)
- Bearings** Synthetic sleeve type
- Axles** ½ in. dia. zinc plated steel
- Construction** . . . Mechanically fastened
- Birdscreen** 3/4 in. x 0.051 in. flattened expanded aluminum in removable frame, inside mount (rear)
- Finish** Mill
- Minimum Size** . . 12 in. W x 16 in. H
- Maximum Single Section Size** . . . 60 in. W x 96 in. H

Options (at additional cost)

- A variety of bird and insect screens
- A variety of electric, pneumatic or manual actuators
- Clip angles
- Extended sill
- Filter rack
- Flanged frame
- Glazing adaptor
- Hinged frame
- Security bars
- A variety of architectural finishes including:
 - Clear anodize
 - Integral color anodize
 - Baked enamel paint
 - Kynar paint

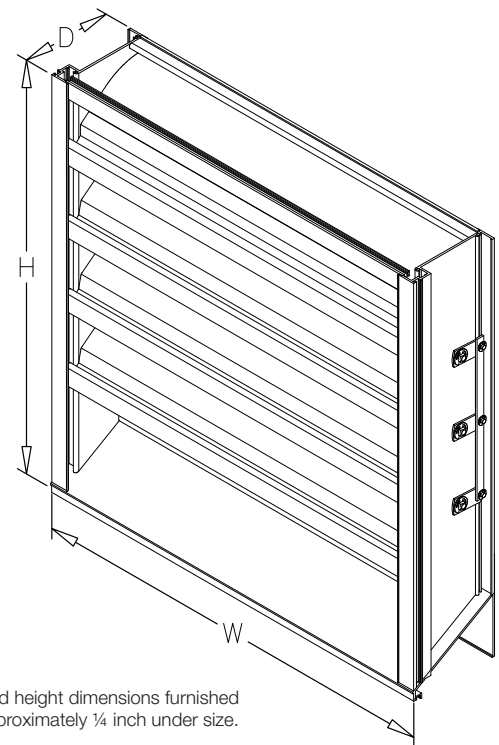
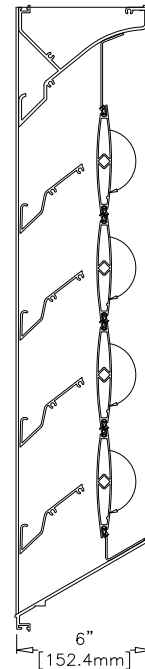

*Width and height dimensions furnished approximately ¼ inch under size.

PERFORMANCE DATA

EACA-601

Combination Louver/Damper
Extruded Aluminum

Free Area Chart (Sq. ft.)

Louver Height Inches	Louver Width in Inches													
	12	15	18	21	24	27	30	33	36	39	42	48	54	60
16	0.20	0.27	0.33	0.40	0.46	0.53	0.59	0.66	0.72	0.79	0.85	0.98	1.11	1.24
21	0.40	0.52	0.65	0.78	0.91	1.04	1.17	1.30	1.42	1.55	1.68	1.94	2.20	2.45
24	0.59	0.78	0.98	1.17	1.36	1.55	1.74	1.94	2.13	2.32	2.51	2.90	3.28	3.66
30	0.79	1.04	1.30	1.55	1.81	2.06	2.32	2.58	2.83	3.09	3.34	3.85	4.36	4.87
33	0.97	1.28	1.60	1.91	2.22	2.54	2.85	3.17	3.48	3.79	4.11	4.74	5.37	5.99
39	1.18	1.56	1.94	2.33	2.71	3.09	3.47	3.85	4.24	4.62	5.00	5.77	6.53	7.30
42	1.34	1.77	2.21	2.64	3.07	3.51	3.94	4.38	4.81	5.24	5.68	6.55	7.41	8.28
48	1.57	2.08	2.59	3.10	3.61	4.12	4.62	5.13	5.64	6.15	6.66	7.68	8.70	9.72
51	1.57	2.08	2.59	3.10	3.61	4.12	4.62	5.13	5.64	6.15	6.66	7.68	8.70	9.72
60	1.96	2.60	3.23	3.87	4.51	5.14	5.78	6.41	7.05	7.69	8.32	9.59	10.87	12.14
66	2.33	3.08	3.84	4.59	5.35	6.10	6.85	7.61	8.36	9.12	9.87	11.38	12.89	14.40
78	2.74	3.63	4.52	5.41	6.30	7.19	8.08	8.97	9.86	10.75	11.64	13.42	15.20	16.98
84	2.94	3.89	4.85	5.80	6.75	7.71	8.66	9.61	10.56	11.52	12.47	14.38	16.28	18.19
96	3.53	4.67	5.81	6.96	8.10	9.24	10.39	11.53	12.67	13.82	14.96	17.25	19.54	21.82

Air Leakage (with damper section closed) Test size 48 in. x 48 in.

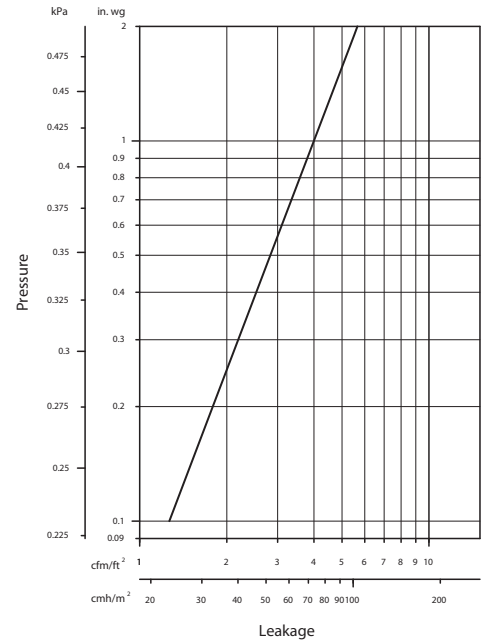



Greenheck Fan Corporation certifies that the EACA-601 louvers shown herein are licensed to bear the AMCA Seal. The ratings shown are based on tests and procedures performed in accordance with AMCA Publication 511 and comply with the requirements of the AMCA Certified Ratings Program. The AMCA Certified Ratings Seal applies to air performance and water penetration ratings.

Water Penetration (Standard Air - .075 lb/ft³) Test size 48 in. x 48 in. Test duration of 15 min.

Airflow Resistance (Standard Air - .075 lb/ft³)

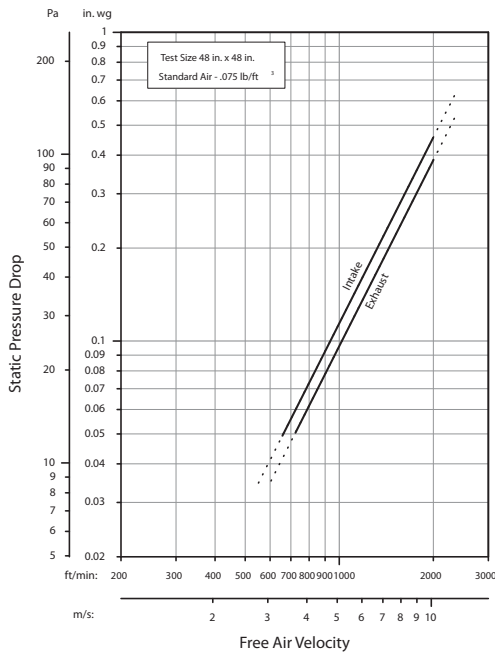

Model EACA-601 resistance to airflow (pressure drop) varies depending on louver application (air intake or air exhaust). Free area velocities (shown) are higher than average velocity through the overall louver size. See louver selection information.

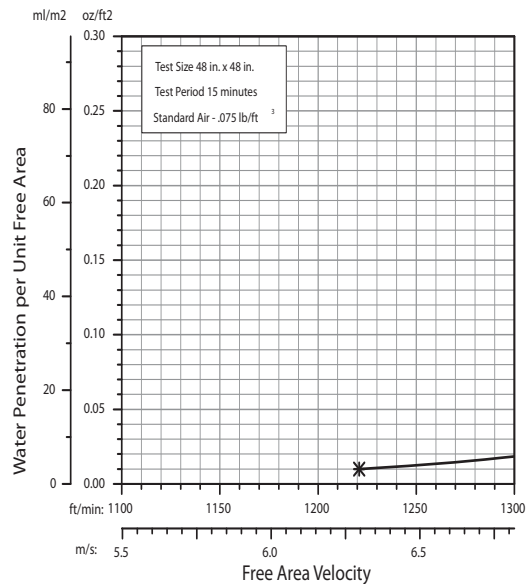

The AMCA Water Penetration Test provides a method for comparing various louver models and designs as to their efficiency in resisting the penetration of rainfall under specific laboratory test conditions. The beginning point of water penetration is defined as that velocity where the water penetration curve projects through .01 oz. of water (penetration) per sq. ft. of louver free area. ***The beginning point of water penetration for Model EACA-601 is 1221 fpm free area velocity.** These performance ratings do not guarantee a louver to be weatherproof or stormproof and should be used in combination with other factors including good engineering judgement in selecting louvers.



INSTALLATION DETAILS

EACA-601

Maximum Size and Installation Information

Combination Louver/Damper
Extruded Aluminum

The maximum single section size for the EACA-601 is 60 in. W x 96 in. H. Larger openings require field assembly of multiple louver panels to make up the overall opening size. Individual louver panels are designed to withstand a 25 PSF wind-load (please consult Greenheck if the louvers must withstand higher wind-loads). Structural reinforcing members may be required to adequately support and install multiple louver panels within a large opening. Structural reinforcing members along with any associated installation hardware is not provided by Greenheck unless indicated otherwise by Greenheck. Additional information on louver installation may be found in AMCA Publication #501, Louver Application Manual.

SINGLE SECTION

MULTIPLE SECTION W/ MULLION

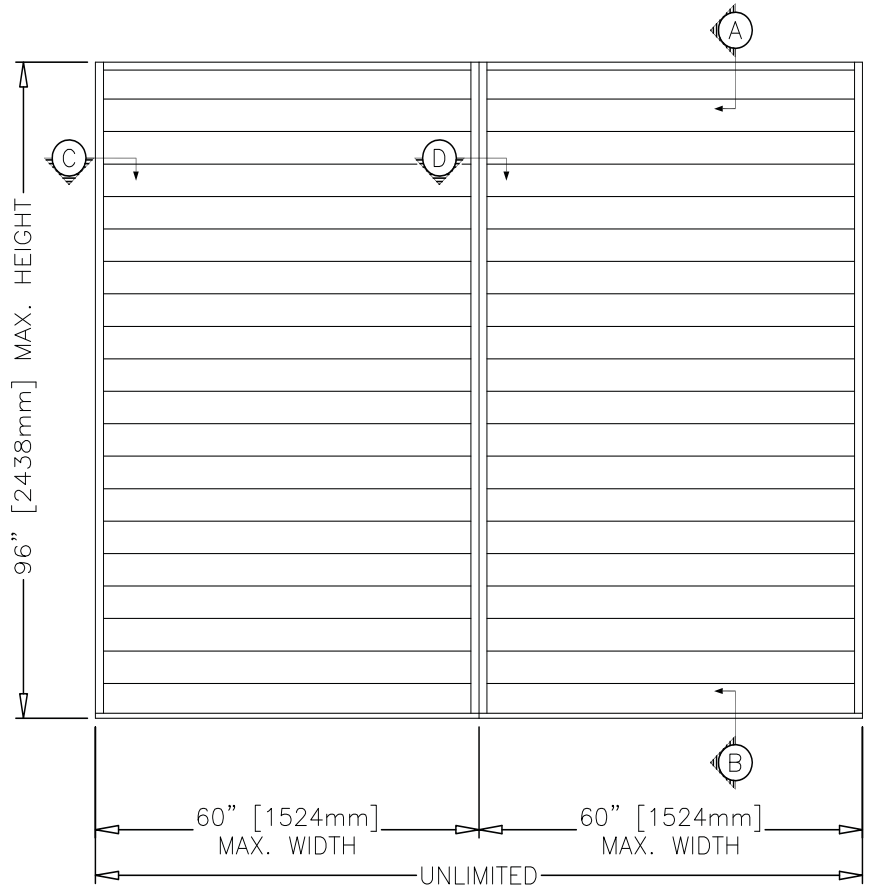
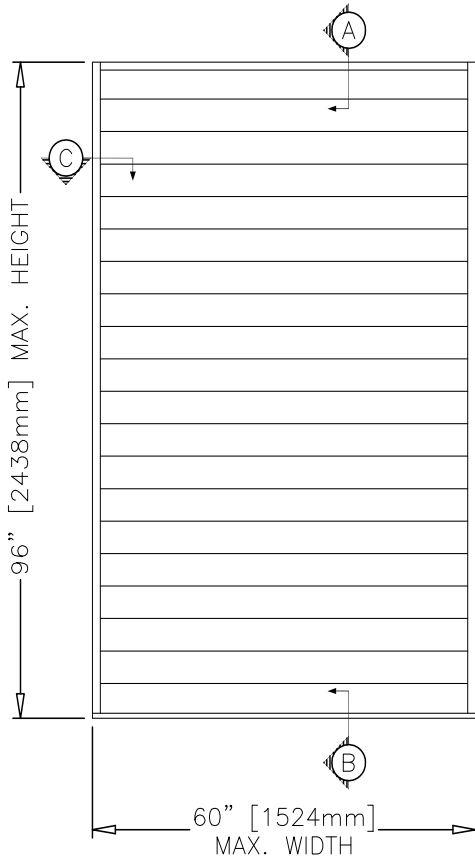

Minimum Single Section Size

12 in. W x 16 in. H

Maximum Single Section Size

60 in. W x 96 in. H

PRODUCT DETAILS

EACA-601

Combination Louver/Damper
Extruded Aluminum

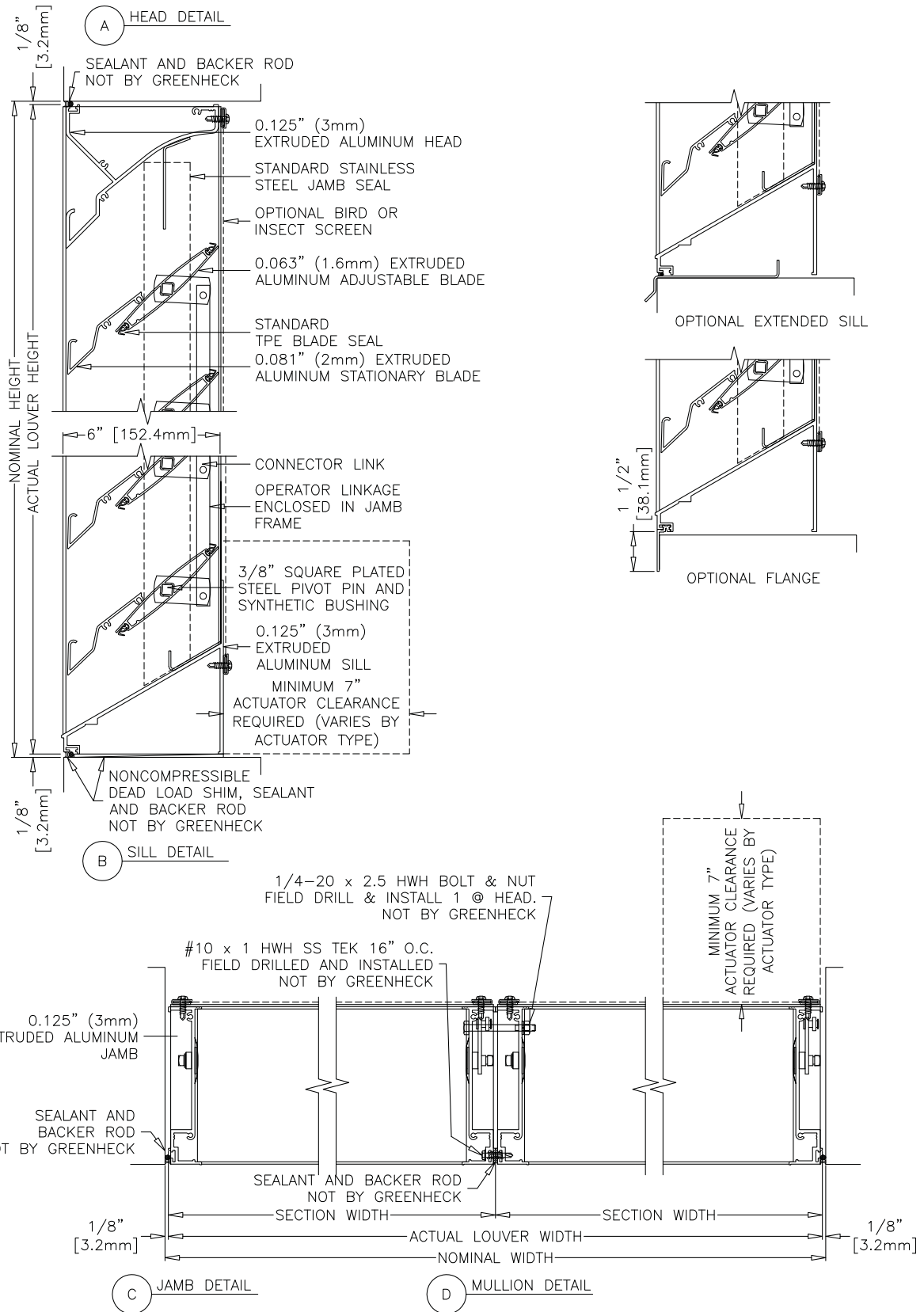

OPTION DRAWINGS

EACA-601

Combination Louver/Damper Extruded Aluminum

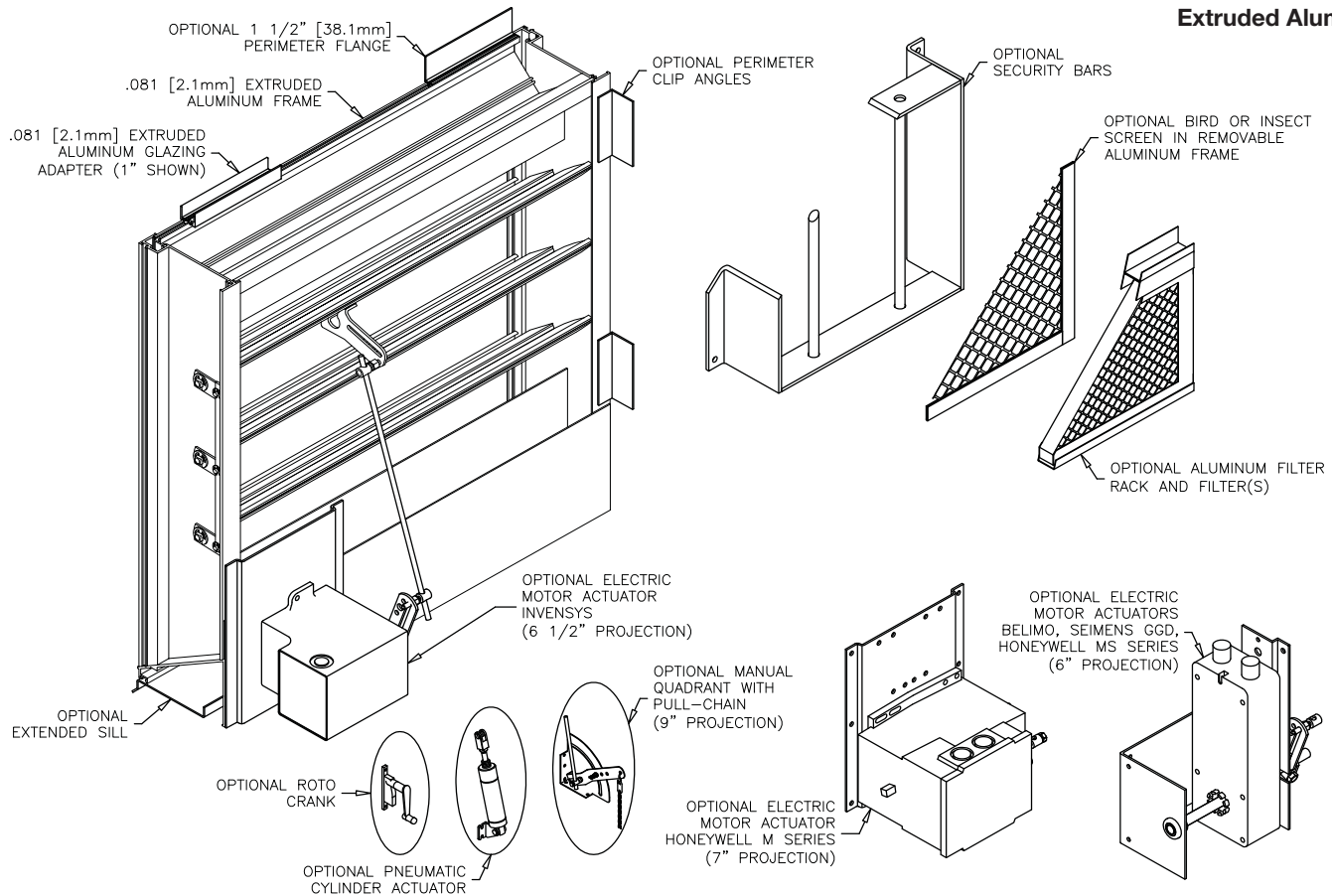

FINISHES

Finish Type	Description/Application	Color Selection	Standard Warranty (Aluminum)
2-coat 70% KYNAR 500®/HYLAR 5000® AAMA 2605 – Dry film thickness 1.2 mil. (AKA: Duranar®, Fluoropon®, Trinar®, Flouropolymer, Polyvinylidene Fluoride, PVDF2)	"Best." The premier finish for extruded aluminum. Tough, long-lasting coating has superior color retention and abrasive properties. Resists chalking, fading, chemical abrasion and weathering.	Standard Colors: Any of the 24 standard colors shown can be furnished in 70% or 50% KYNAR 500®/HYLAR 5000® or Baked Enamel. 2-Coat Mica: Greenheck offers 9 standard 2-coat Mica colors. Other colors are available. Consult Greenheck for possible extra cost when selecting non-standard colors or special finishes.	10 Years (Consult Greenheck for availability of extended warranty)
2-coat 50% KYNAR 500®/HYLAR 5000® AAMA 2604 – Dry film thickness 1.2 mil. (AKA: Acroflur®, Acrynar®)	"Better." Tough, long-lasting coating has excellent color retention and abrasive properties. Resists chalking, fading, chemical abrasion and weathering.		5 Years
Baked Enamel AAMA 2603 – Dry film thickness 0.8 mil. (AKA: Acrabond Plus®, Duracron®)	"Good." Provides good adhesion and resistance to weathering, corrosion and chemical stain.		1 Year
Integral Color Anodize AA-M10C22A42 (>0.7 mil)	"Two-step" anodizing is produced by following the normal anodizing step with a second, colorfast process.	Light, Medium or Dark Bronze; Champagne; Black	5 years
Clear Anodize 215 R-1 AA-M10C22A41 (>0.7 mil)	Clear, colorless and hard oxide aluminum coating that resists weathering and chemical attack.	Clear	5 years
Clear Anodize 204 R-1 AA-M10C22A31 (0.4-0.7 mil)	Clear, colorless and hard oxide aluminum coating that resists weathering and chemical attack.	Clear	1 Year
Industrial coatings	Greenheck offers a number of industrial coatings such as Hi-Pro Polyester, Epoxy, and Permator®. Consult a Greenheck Product Specialist for complete color and application information.		Consult Greenheck
Mill	Materials may be supplied in natural aluminum or galvanized steel finish when normal weathering is acceptable and there is no concern for color or color change.		n/a

Finishes meet or exceed AAMA 2605, AAMA 2604, and AAMA 2603 requirements. Please consult www.greenheck.com for complete information on standard and extended paint warranties. Paint finish warranties are not applicable to steel products.



EACA-601
September 2007 Rev. 3
Copyright © 2007 Greenheck Fan Corporation

Greenheck Fan Corporation reserves the right to make product changes without notice.

MS4120F; MS4620F,S; MS8120F,S; S2024-F; S20230-F Fast-Acting, Two-Position Actuators

PRODUCT DATA



FEATURES

- 175 lb-in. (20 N•m) minimum driving torque at 350°F (176°C).
- Reversible mounting facilitates use in either clockwise (cw) or counterclockwise (ccw) spring rotation.
- Integral spring return ensures level of return torque.
- Stainless steel internal spring.
- Fifteen-second spring return timing.
- No special cycling required during long-term holding. (See Operation section.)
- No audible noise during holding.
- Patent pending design eliminates need for limit switches to reduce power consumption.
- Models available for 24, 120, and 230 Vac applications.
- Ninety-five degree angle of rotation.
- Actuator holds rated torque at reduced power level.
- Die-cast aluminum housing.
- Housing design allows flush mounting to damper.
- Self-centering shaft adapter (SCSA), patent pending.
- Designed to operate reliably in smoke control systems requiring Underwriter's Laboratories Inc. UL555S ratings up to 350°F.

APPLICATION

The MS4120F, MS4620F, MS8120F, S2024-F, and S20230-F Fast-Acting, Two-Position Actuators are spring return direct coupled actuators (DCA) for on/off damper control. The actuator accepts an on/off signal from a single-pole, single-throw (spst) controller. Reversible mounting allows actuator to be used for either clockwise (cw) or counterclockwise (ccw) spring rotation.

Designed to operate reliably in smoke control systems requiring Underwriter's Laboratories Inc. UL555S ratings up to 350°F.

APPLICABLE LITERATURE

— Specification Data Sheet	63-2592
— Motor/Actuator Selection Guide for Damper Applications	63-8419
— Engineering Manual of Automatic Control (also called The Gray Manual)	77-1100
— Direct Coupled Actuator Quick Selection Guide	63-8553
— Damper Torque Calculator	63-8437

MS4120F, MS4620F, MS8120F

- High temperature Teflon® lead wires.
- Models available with integral high temperature (350°F) SPST position-indicating switches (7°, 85° stroke).

S2024-F, S20230-F, MS4620S, MS8120S

- Double-insulation rating.
- High-temperature, halogen-free, silicone-free leadwires.
- Models available with integral high temperature (350°F) SPST position-indicating switches (7°, 85° stroke).



SPECIFICATIONS

Models: See Tables 1, 2, and 3.

Table 1. Models.

Model	Voltage in Vac	Internal Auxiliary Switches
MS4120F1006	120	None
MS4120F1204	120	2 SPST ^a
MS4620F1005	230	None
MS4620F1203	230	2 SPST ^a
MS8120F1002	24	None
MS8120F1200	24	2 SPST ^a
S2024-F (MS8120S1006)	24	None
S20230-F (MS4620S1009)	230	
S2024-F-SW2 (MS8120S1204)	24	2 SPDT ^a
S20230-F-SW2 (MS4620S1207)	230	

^a Internal switches are designed to pass UL555S requirements (at 350°F).

Dimensions: See Fig. 1.

Device Weight: 7 lb (3.2 kg).

Stroke: 95° ± 3°, mechanically limited.

Electrical Ratings:

Power Input:

MS4120F: 120 Vac ±10%, 60 Hz.
 MS4620F,S; S20230-F: 230 Vac ±10%, 50/60 Hz.
 MS8120F,S; S2024-F: 24 Vac +20%, -10%, 50/60 Hz (Class 2).

Power Consumption:

MS4120F: Driving: 0.35A, 35W. Holding: 0.15A, 10W.
 MS4620F,S; S20230-F:
 Driving: 0.20A, 35W. Holding: 0.14A, 10W.
 MS8120F,S; S2024-F: Driving: 45 VA. Holding: 10 VA.

Electrical Connections:

Lead Wires:

MS4120F, MS4620F, MS8120F: 1m Teflon wire.
 MS4620S, MS8120S, S2024-F, S20230-F: 1m halogen-free, silicone-free wire.

Two integral 3/8 in. flexible conduit connections.

Timing (At Rated Torque and Voltage):

Drive Open: 15 seconds typical.
 Spring Close: 15 seconds typical.

Auxiliary Switches:

Ratings (maximum load): 250 Vac, 5A resistive, 3A inductive.
 Settings (fixed): 7° nominal stroke, 85° nominal stroke.

Torque Rating (at Rated Voltage):

Typical Holding (minimum at 350°F): 175 lb-in. (20 N•m).
 Spring Return (minimum at 350°F): 175 lb-in. (20 N•m).
 Stall Maximum (fully open at 75°F): 425 lb-in. (48.0 N•m).
 350°F Minimum Driving: 175 lb-in. (20 N•m).

Design Life (at Rated Voltage): 30,000 full stroke cycles.

Minimum Damper Shaft Length:

1 in. (25 mm); 3-1/4 (83 mm) recommended.

Cycling Requirements:

Prolonged holding-period (1 year) testing of these actuators has been performed with no spring return failures. The actuator and the internal spring are designed to require no special cycling during long-term holding.

Honeywell recommends following all local, state and national codes for periodic testing of the entire smoke control system. Refer to National Fire Protection Association (NFPA) National Fire Codes®: NFPA90A, NFPA92A and NFPA92B for your application.

NFPA recommends periodic examination of each fire/smoke damper (semi-annually or annually) to ensure proper performance.

Mounting: Self-centering shaft adapter.

Round Damper Shafts: 0.5 to 1.06 in.
 Square Damper Shafts: 1/2 to 3/4 in.
 Actuator can be mounted with shaft in any position.

IMPORTANT

- Honeywell does not recommend using linkages with these actuators because side-loading of the output hub reduces actuator life.
- 3/4 in. or greater shaft diameter recommended.

Noise Rating at 1m (Maximum):

Driving or Spring Return: 70 dBA.
 Holding: 20 dBA (no audible noise).

ORDERING INFORMATION

When purchasing replacement and modernization products from your TRADELINE® wholesaler or distributor, refer to the TRADELINE® Catalog or price sheets for complete ordering number.

If you have additional questions, need further information, or would like to comment on our products or services, please write or phone:

1. Your local Honeywell Automation and Control Products Sales Office (check white pages of your phone directory).
2. Honeywell Customer Care
 1885 Douglas Drive North
 Minneapolis, Minnesota 55422-4386

In Canada—Honeywell Limited/Honeywell Limitée, 35 Dynamic Drive, Scarborough, Ontario M1V 4Z9.

International Sales and Service Offices in all principal cities of the world. Manufacturing in Australia, Canada, Finland, France, Germany, Japan, Mexico, Netherlands, Spain, Taiwan, United Kingdom, U.S.A.

Temperature Ratings:

Ambient: -40°F to 130°F (-40°C to 55°C).
 Shipping and Storage: -40°F to 140°F (-40°C to 60°C).

IMPORTANT

The actuator is designed to meet UL555S standards at 350°F (176°C). The actuator must be tested with the damper to achieve this rating.

NOTE: The actuator is designed to operate for 30 minutes during a one-time excursion to 350°F (176°C).

Humidity Ratings: 5% to 95% RH noncondensing.

Environmental Protection Ratings:

NEMA2 and IP54 when mounted on a horizontal shaft.

Accessories:

205649 Mounting Bracket (not supplied with actuator).

Approvals: See Table 4.

Controller Type:

MS4120F: Line voltage (120 Vac), 2-position, spst (Series 40).
 MS4620F,S; S20230-F: Line voltage (230 Vac), 2-position, spst (Series 40).
 MS8120F,S; S2024-F: Low voltage (24 Vac), 2-position, spst (Series 80).

Table 2. Actuator Selection (MS Series).

M	Electrical Motor						
S	Fail Safe Function (Spring Return)						
41	120 Vac 2-position Control; Reversible Mount Spring Return						
46	230 Vac 2-position Control; Reversible Mount Spring Return						
81	24 Vac 2-position Control; Reversible Mount Spring Return						
20	175 lb-in. (20 N•m)						
F	Fire and Smoke (US)						
S	Fire and Smoke (EU)						
1	No Feedback						
0	No Auxiliary Switches						
2	Two Auxiliary Switches						
XX	System Controlled Numbers						
M	S	41	20	F	1	2	XX

Table 3. Actuator Selection (S20 Series).

S	Fail Safe Function (Spring Return)					
20	20 N•m (175 lb-in.)					
24	24 Vac 2-position Control; Reversible Mount Spring Return					
230	230 Vac 2-position Control; Reversible Mount Spring Return					
F	Fire and Smoke Actuator					
	No Auxiliary Switches					
-SW2	Two Auxiliary Switches					
S	20	24	-	F	-	-SW2

Table 4. Approvals.

	MS4120F	MS4620F, MS8120F	S20230-F, S2024-F, MS4620S, MS8120S
UL/cUL	X	X	
UL873 Plenum Rating, File No. E4436; Guide No. XAPX. ^a	X	X	
CE		X	X
C-TICK		X	X

^a Plenum applications require that conductors be enclosed in conduit (see Wiring section for conduit details).

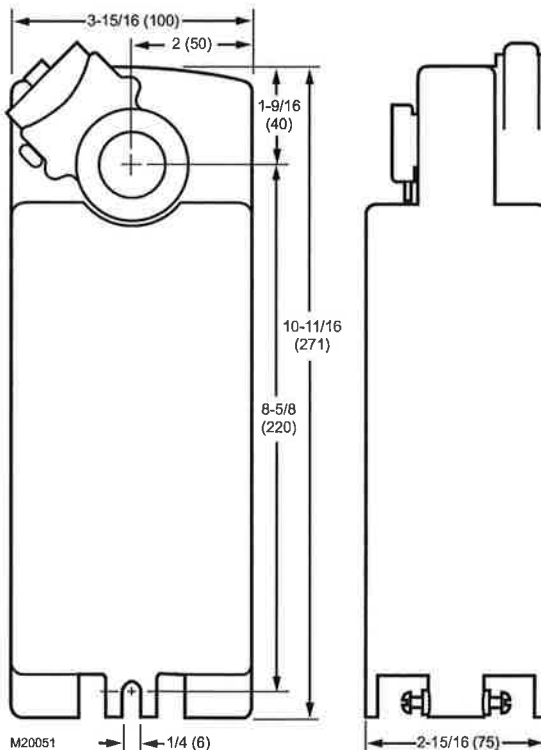

Fig. 1. Dimensional drawing of actuator in inches (mm).

INSTALLATION

When Installing this Product...

1. Read these instructions carefully. Failure to follow them could damage the product or cause a hazardous condition.
2. Check the ratings given in the instructions and on the product to make sure the product is suitable for your application.
3. Installer must be a trained, experienced service technician.
4. After installation is complete, check out product operation as provided in these instructions.

! WARNING

Electrical Power Hazard.
Line voltage can cause death or serious injury and short equipment circuitry.
Disconnect power supply before installation.



! CAUTION

Electrical Shock or Equipment Damage Hazard.
Low voltage can shock individuals or short equipment circuitry.
Disconnect power supply before installation.

IMPORTANT

All wiring must agree with applicable codes, ordinances and regulations.

Location

The actuators are designed to open a damper by driving the damper shaft in either a clockwise  or counterclockwise  direction. The actuator housing has two slots on the bottom, either of which, with a 205649 Mounting Bracket, secures it flush to a damper box (see Fig. 2).

NOTE: When mounted correctly, these slots allow the actuator to *float* without rotating relative to the damper shaft.

! CAUTION

Equipment Damage Hazard.
Tightly securing actuator to damper housing can damage actuator.
Mount actuator to allow it to float along its vertical axis.

Preparation

Before mounting the actuator onto the damper shaft, determine the:

- Damper/valve opening direction for correct spring return rotation. The actuator can be mounted to provide clockwise or counterclockwise spring return.
- Damper shaft size (see Specifications section).

Determine Appropriate Mounting Orientation

See Fig. 2 for mounting orientation.

NOTES:

- Actuators are shipped in the fully closed position.
- An arrow molded into the hub points to tick marks on the label to indicate the hub rotary position.
- See Fig. 3 for proper mounting to a square damper shaft.

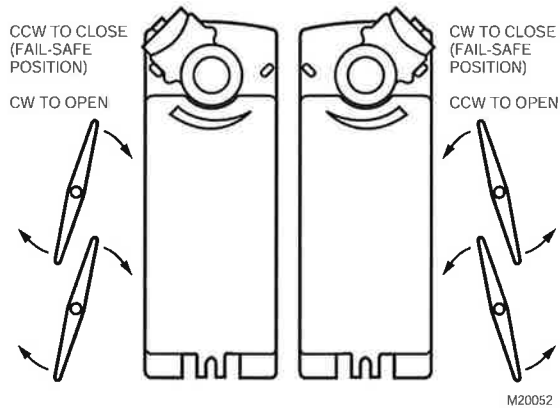

Fig. 2. Spring Return DCA mounting orientation.

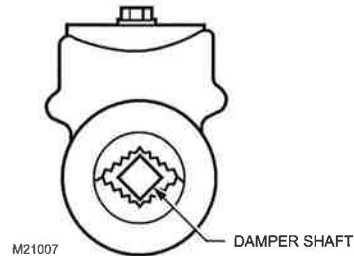

Fig. 3. Proper mounting to square damper shaft.

Measure Damper/Valve Shaft Length

If the shaft is less than three inches in length, the shaft coupling must be located between the damper/valve and actuator housing. If the shaft length is more than three inches, the shaft coupling may be located on either side of the actuator housing.

If the coupling must be moved from one side of the actuator to the reverse, follow these instructions (see Fig. 4):

1. Remove the retainer clip from the shaft coupling and set it aside for later use.
2. Remove shaft coupling from one side of the actuator.
3. Replace the shaft coupling on the opposite side of the actuator aligning it based on the stroke labelling.
4. Replace the retainer clip on the shaft coupling using the groove of the coupling.

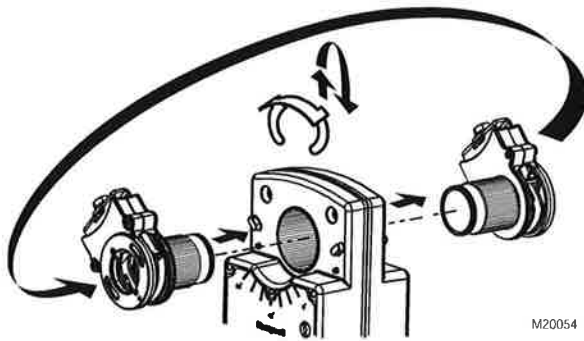

Fig. 4. Mounting shaft coupling to actuator opposite side.

Mounting



CAUTION

Device Malfunction Hazard.
Improper shaft coupling tightening causes device malfunction.

Tighten shaft coupling with proper torque to prevent damper shaft slippage.



CAUTION

Actuator Damage Hazard.
Using actuator as shaft bearing causes device damage.

Use actuator only to supply rotational torque. Avoid any side loads to actuator output coupling bearings.

To mount actuator, proceed as follows:

1. Place actuator over damper shaft; and hold mounting bracket in place. See Fig. 5.
2. Mark screw holes on damper housing.
3. Remove actuator and mounting bracket.
4. Drill or center-punch holes for mounting screws (or use no. 10 self-tapping sheet metal screws).

NOTE: If necessary, use a field-fabricated steel base plate secured with sheet metal screws.

5. Turn damper blades to desired normal (closed) position.
6. Place actuator and mounting bracket back into position and secure bracket to damper box with sheet metal screws.
7. Using 10 mm wrench, tighten shaft coupling securely onto damper shaft using minimum 120 lb-in., maximum 180 lb-in. torque.

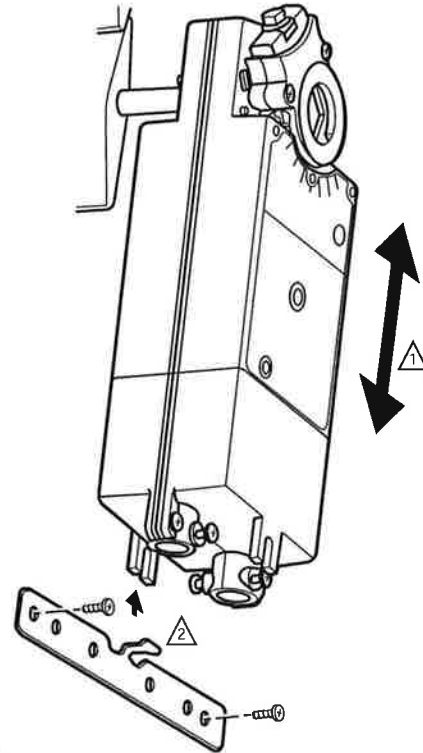

ENSURE THAT MOUNTING ASSEMBLY PREVENTS ACTUATOR ROTATION AND ALLOWS ACTUATOR TO FLOAT ALONG INDICATED AXIS. WHEN TOO TIGHT, THE RESULTING BINDING CAN DAMAGE THE ACTUATOR OR REDUCE TORQUE OUTPUT.



ACCESSORY MOUNTING BRACKET IS NOT SUPPLIED WITH THE ACTUATOR.

M20055

Fig. 5. Mounting actuator to damper housing.

WIRING

See Fig. 6 through 10 for typical wiring diagrams.

⚠ WARNING

Electrical Power Hazard.
Line voltage can cause death or serious injury and short equipment circuitry.
Disconnect power supply before installation.

⚠ CAUTION

Electrical Shock or Equipment Damage Hazard.
Disconnect all power supplies before installation.
Motors with auxiliary switches can have more than one disconnect.

IMPORTANT

1. All wiring must comply with local electrical codes, ordinances and regulations.
2. Voltage and frequency of transformer used with MS8120F,S and S2024-F must correspond with the characteristics of power supply and actuator.

NOTE: The conduit fittings are designed for use with 3/8 in. reduced-wall steel or aluminum flexible conduit.

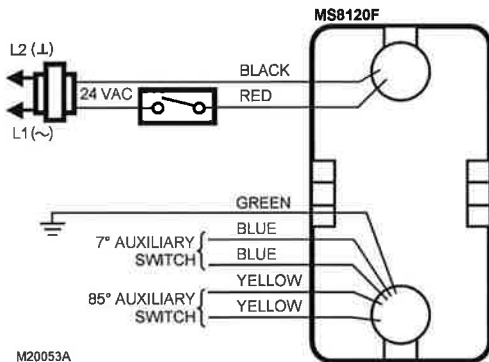

Fig. 6. Typical 24 Vac wiring (MS Series).

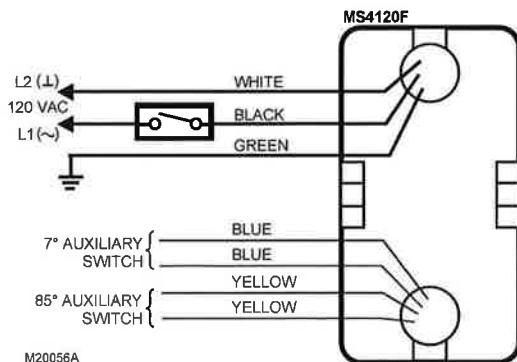

Fig. 7. Typical 120 Vac wiring (MS Series).

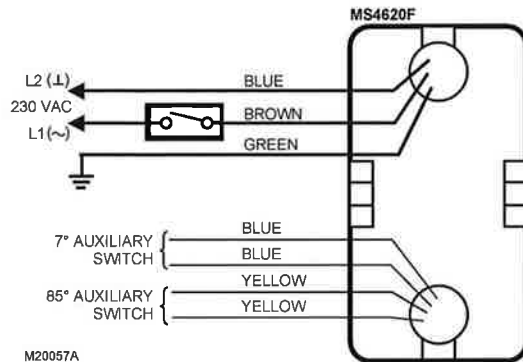

Fig. 8. Typical 230 Vac wiring (MS Series).

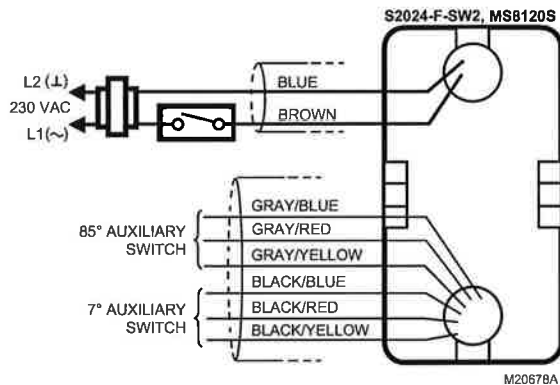

Fig. 9. Typical 24 Vac wiring (S20 Series).

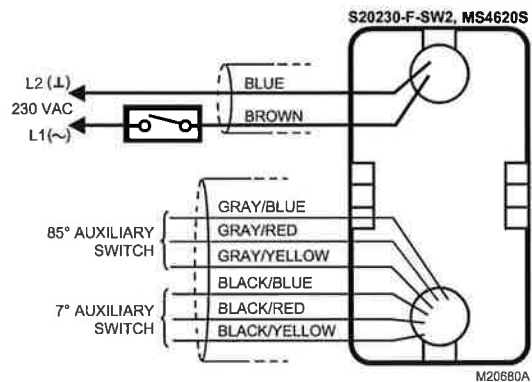

Fig. 10. Typical 230 Vac wiring (S20 Series).

OPERATION

The actuators are designed for use in Smoke Control Systems. If power fails, the actuator spring returns to the 0° position. The actuator mounts flush with the damper box. The actuator drives from 0° to 95° and spring returns back to 0°.

The actuators are operated by an spst two-position controller. When using an spst two-position controller, the actuator drives to the damper fully open position when controller contact makes and spring returns to the damper fully closed position when controller contact breaks. The actuator drops to holding power level on detection of stall, independent of hub position.

Cycling

The actuator and the internal spring are designed so that no special cycling during long-term holding is required. Honeywell recommends following all local, state, and national codes for periodic testing of the entire smoke control system. Refer to National Fire Protection Association (NFPA) National Fire Codes®: NFPA90A, NFPA92A, and NFPA92B for your application.

Auxiliary Switches

Some models include auxiliary switches (see Table 1).

SPST Switches (Table 5)

See Fig. 6 through 8 for SPST auxiliary switch wiring.

Table 5. SPST Auxiliary Switch Operation.

Switch	Wire Color	Makes	Breaks
		(degrees from fully closed position)	
7°	blue	less than 7	greater than 7
85°	yellow	greater than 85	less than 85

NOTE: Both sets of contacts are open when the actuator is between 7° and 85°.

SPDT Switches (Fig. 11)

See Fig. 9 through 11 for SPDT auxiliary switch wiring.

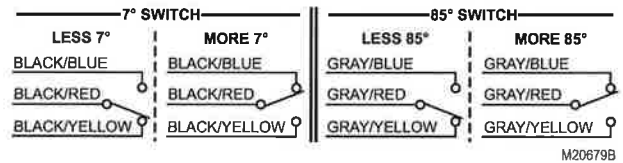

Fig. 11. SPDT auxiliary switch operation.

CHECKOUT

MS4120F (120 Vac model)

1. Check damper position.
2. Connect 120 Vac to the black and white leadwires to drive the damper to the open position. The actuator should drive the damper.
3. If the actuator does not run, remove power for at least two seconds.
4. If the actuator spring returns, allow it to close entirely, then return to step 2.
5. If the actuator does not spring return, verify that the actuator is properly installed. See Installation section.
6. If the actuator is correctly installed but neither runs nor spring returns, replace the actuator.

MS4620F,S; S20230-F (230 Vac models)

1. Check damper position.
2. Connect 230 Vac to the blue and brown leadwires to drive the damper to the open position. The actuator should drive the damper.

3. If the actuator does not run, remove power for at least two seconds.
4. If the actuator spring returns, allow it to close entirely, then return to step 2.
5. If the actuator does not spring return, verify that the actuator is properly installed. See Installation section.
6. If the actuator is correctly installed but neither runs nor spring returns, replace the actuator.

MS8120F,S; S2024-F (24 Vac models)

1. Check damper position.
2. Connect 24 Vac to the red and black leadwires to drive the damper to the open position. The actuator should drive the damper.
3. If the actuator does not run, remove power for at least two seconds.
4. If the actuator spring returns, allow it to close entirely, then return to step 2.
5. If the actuator does not spring return, verify that the actuator is properly installed. See Installation section.
6. If the actuator is correctly installed but neither runs nor spring returns, replace the actuator.

D Montageanweisung

F Instructions d'Installation

I Istruzioni per l'Installazione

NL Installatievoorschrift

DK Installasjonsinstruks

N Installationsinstruktioner

SF Asennusohje

S Installations Instruktioner

E Instrucciones de montaje

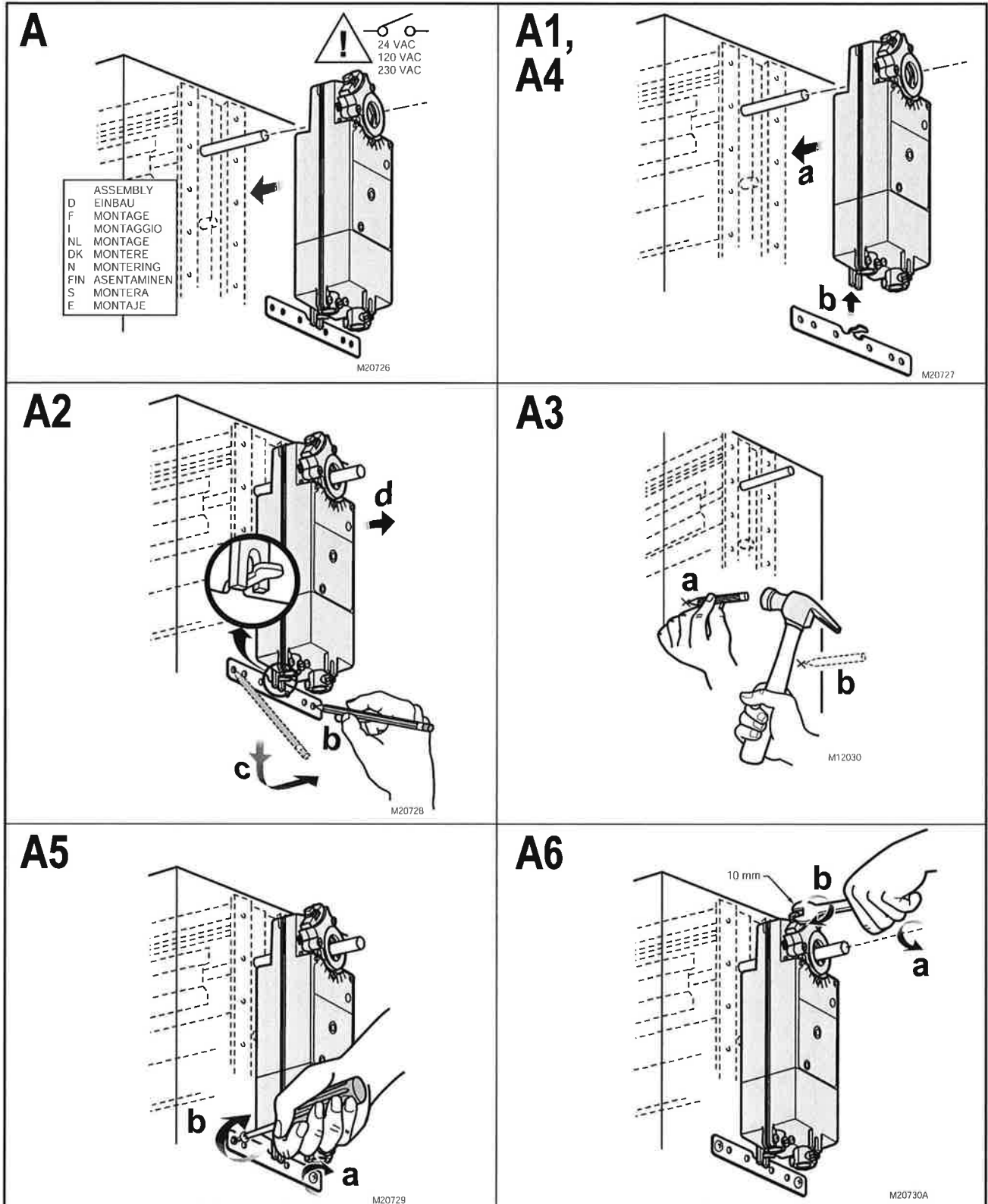

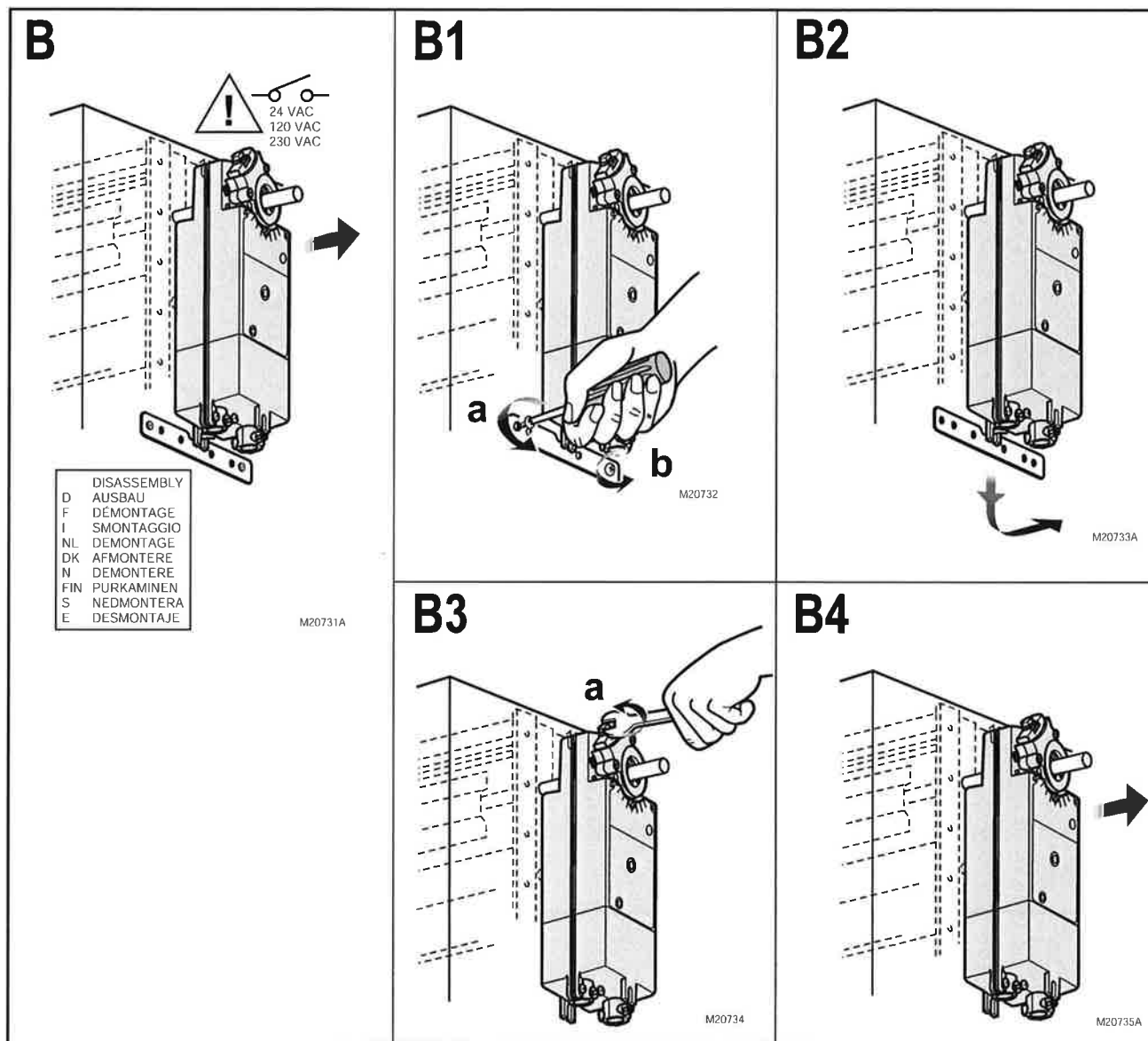

MS4120F; MS4620F,S; MS8120F,S; S2024-F; S20230-F FAST-ACTING, TWO-POSITION ACTUATORS

MS4120F; MS4620F,S; MS8120F,S; S2024-F; S20230-F FAST-ACTING, TWO-POSITION ACTUATORS

Teflon® is a registered trademark of the E.I. du Pont de Nemours and Company.

National Fire Codes® is a registered trademark of the National Fire Protection Association (NFPA).

Automation and Control Solutions

Honeywell International Inc.
1985 Douglas Drive North
Golden Valley, MN 55422
customer.honeywell.com

Honeywell Limited-Honeywell Limitée
35 Dynamic Drive
Scarborough, Ontario M1V 4Z9

© U.S. Registered Trademark
© 2006 Honeywell International Inc.
63-2584—7 C.H. Rev. 03-06



Printed in U.S.A. on recycled
paper containing at least 10%
post-consumer paper fibers.

Honeywell