



# McDade-Woodcock, Inc.

TRANSMITTAL

No. 00017

7222 Commerce Center Dr. Suite 245  
Colorado Springs, CO 80919

Phone: 719-264-1236  
Fax: 719-264-1450

**PROJECT:** Harold D. Thompson WRF

**DATE:** 1/25/2012

**TO:** Weaver General Construction

**REF:** Electrical Submittal  
16289-001, 16441-001,  
16442-001, 16461-001  
Electrical Equipment - EQUIP  
MAINT BUILDING

**ATTN:** Wes Weaver

WE ARE SENDING:	SUBMITTED FOR:	ACTION TAKEN:
<input checked="" type="checkbox"/> Shop Drawings	<input checked="" type="checkbox"/> Approval	<input type="checkbox"/> Approved as Submitted
<input type="checkbox"/> Letter	<input type="checkbox"/> Your Use	<input type="checkbox"/> Approved as Noted
<input type="checkbox"/> Prints	<input type="checkbox"/> As Requested	<input type="checkbox"/> Returned After Loan
<input type="checkbox"/> Change Order	<input checked="" type="checkbox"/> Review and Comment	<input type="checkbox"/> Resubmit
<input type="checkbox"/> Plans		<input checked="" type="checkbox"/> Submit
<input type="checkbox"/> Samples	<b>SENT VIA:</b>	<input type="checkbox"/> Returned
<input type="checkbox"/> Specifications	<input checked="" type="checkbox"/> Attached	<input type="checkbox"/> Returned for Corrections
<input type="checkbox"/> Other:	<input type="checkbox"/> Separate Cover Via	<input checked="" type="checkbox"/> Due Date: 2/15/2012

ITEM	PACKAGE	SUBMITTAL	DRAWING	REV.	ITEM NO.	COPIES	DATE	DESCRIPTION	STATUS
					001	1	1/25/2012	Electrical Submittal 16289-001 - Surge Protection Device 16441-001 - Switch Boards 16442-001 - Panelboards 16461-001 - Low Voltage (Dry Type) Transformers ELECTRICAL EQUIPMENT - EQUIPMENT MAINTENANCE BLDG.	TERM

**Remarks:** Electrical Submittal for Review and Approval  
Via Email Only

CC:

Signed:

  
Janelle L. Smith



McDADE-WOODCOCK, INC.

**HAROLD D. THOMPSON RWRF  
EQUIPMENT MAINTENANCE BLDG.**

**McDADE-WOODCOCK INC.  
PROJECT NUMBER - 1402**

**ELECTRICAL SUBMITTAL**

**ELECTRICAL EQUIPMENT**

**16289-001 (Surge Protection Device)**

**16441-001 (Switch Boards)**

**16442-001 (Panel Boards)**

**16461-001 (Low Voltage Transformers)**

**CORPORATE**

2404 Claremont Ave. NE  
Albuquerque, NM 87107

Mailing Address  
P.O. Box 11592  
Albuquerque, NM 87192

Ph 505-884-0155  
Fax 505-884-6073

**DENVER**

10700 E. Geddes Avenue  
Suite 170  
Englewood CO 80112

Ph 303-803-1809  
Fax 303-803-1818

**COLORADO SPRINGS**

7222 Commerce Center Drive  
Suite 245  
Colorado Springs, CO 80919

Mailing Address  
P.O. Box 7349  
Colorado Springs, CO 80933

Ph 719-264-1236  
Fax 719-264-1450

**Owner:**

**Lower Fountain Metropolitan  
Sewage District  
901 S. Santa Fe Avenue  
Fountain, CO 80817**

**General Contractor:**

**Weaver General Construction Co.  
3679 S. Huron St. – Suite 404  
Englewood, CO 80110**

**Electrical Contractor:**

**McDade-Woodcock, Inc.  
7222 Commerce Center Dr.  
#245  
Colorado Springs, CO 80919**

**Engineer:**

**GMS Inc.  
611 N. Weber St., Suite 300  
Colorado Springs, CO 80903**



McDADE-WOODCOCK, INC.

**HAROLD D. THOMPSON RWRF  
EQUIPMENT MAINTENANCE BLDG.**

**McDADE-WOODCOCK INC.  
PROJECT NUMBER - 1402**

**ELECTRICAL SUBMITTAL**

**ELECTRICAL EQUIPMENT**

**16289-001 (Surge Protection Device)**

**16441-001 (Switch Boards)**

**16442-001 (Panelboards)**

**16461-001 (LV Dry-Type Transformers)**

**CORPORATE**

2404 Claremont Ave. NE  
Albuquerque, NM 87107

Mailing Address  
P.O. Box 11592  
Albuquerque, NM 87192

Ph 505-884-0155  
Fax 505-884-6073

**DENVER**

10700 E. Geddes Avenue  
Suite 170  
Englewood CO 80112

Ph 303-803-1809  
Fax 303-803-1818

**COLORADO SPRINGS**

7222 Commerce Center Drive  
Suite 245  
Colorado Springs, CO 80919

Mailing Address  
P.O. Box 7349  
Colorado Springs, CO 80933

Ph 719-264-1236  
Fax 719-264-1450

**TABLE OF CONTENTS**

**TAB 1: TECHNICAL DATA for  
16289 - Surge Protection Device  
and 16441 - Switch Boards**

**TAB 2: TECHNICAL DATA for  
16442 - Panelboards**

**TAB 3: TECHNICAL DATA for  
16461 - LV Dry-Type Transformers**





**TAB 1 Switchboards**

**SURGE PROTECTION DEVICE**

# EATON

## Technical Data

01/21/12

Job Name: HDT RWRF

14:45:35

SDN0301918

**Customer Bill of Material**

1 PRLC Switchboard

Pow-R-Line C Switchboard, Front Access/ Front and Rear Align, Type 1

480Y/277V 3-Phase 4-Wire, 3000 Copper, Minimum Interrupt Rating: 65kA, Bus Bracing Rating: 65kA

- 1 Pow-R-Line C
- 1 3000 Amp Customer Metering - IQ 250, CTs, With Display
- 1 3000 Amp CT's only (3) wired to shorting block
- 2 Vertical Isol. Barrier (Service Entrance)
- 1 Service Entrance Label
- 1 3000 Amp CU Bussed Incoming Pull Section (Density Rated Bus)
- 1 3000 Amp CU Feeder Structure (Density Rated Bus)
- 1 Digitrip RMS310 LSIG-RD
- 8 Nameplate
- 1 3000 Amp CU Distribution Structure (Density Rated Bus)
- 1 Digitrip RMS310 LSI-K/L/M
- 1 Digitrip RMS310 LSIG-ND
- 1 SPD Series 400kA SPD, Standard w/ Surge Counter (Disconnect Included)
- 3 insulated bus
- 1 2000A 3P [RD 2000A Frame], Trip 2000 A., RMS310 LSIG, (6) #4-500 kcmil, Mechanical, Bottom
- 1 800A 3P [HMDL 800A Frame], Trip 800 A., RMS310 LSI, (3) 3/0-400 kcmil, Mechanical
- 1 1200A 3P [HND 1200A Frame], Trip 1200 A., RMS310 LSIG, (4) 4/0-500 kcmil, Mechanical
- 2 3P [HKD 400A Frame] Space,

Designations: MDP-1



### Switchboard General Information

**Pow-R-Line C -Specifications**

Quantity: 1  
 Alignment: Front Access/ Front and Rear Align  
 Service: 480Y/277V 3-Phase 4-Wire Minimum Interrupt Rating: 65 kA

**Bus Specifications**

Bus Amps: 3000 Bus Bracing Rating: 65kA  
 Neutral Amps: 3000  
 Bus Material: Copper Density Rated Bus - 1000A per square inch  
 Copper .25 X 2.0 Ground Bus Bolted To Frame, (1) 350 kcmil Ground Lug

**Incoming Information**

Incoming Entry: Bottom Incoming Location: Left  
 Incoming Qty & Size: Terminals, Mechanical, Bottom, (8) #4-500 kcmil

**Structure Specifications**

Service Entrance  
 Enclosure Type: Type 1  
 Nameplates: None -

**Special Notes**

Qty	Description	Catalog Number
3	insulated bus	CN9077

**Enclosure properties**

Struct #	Description/Modifications
1	Bussed structure with incoming main lugs (Incoming Auxiliary Pull Section) Vertical isolating barrier Auxiliary Bus
2	Individually mounted feeder BREAKER exiting bottom, or SWITCH exiting top or ... Vertical isolating barrier
3	50x chassis mounted feeders (Feeder Structure)

The information on this document is created by Eaton Corporation. It is disclosed in confidence and it is only to be used for the purpose in which it is supplied.

PREPARED BY <b>Fitzgerald, Michael F</b>	DATE <b>01/21/12</b>	<b>Eaton Corporation</b>				<b>Sumter, SC</b>
APPROVED BY	DATE	JOB NAME <b>HDT RWRP</b>	DESIGNATION <b>MDP-1</b>			
VERSION <b>7.8</b>		TYPE <b>Switchboards</b>	DRAWING TYPE <b>Customer Appr.</b>			
NEG-ALT NUMBER <b>DN851005V102-C000</b>	REVISION <b>1</b>	DWG SIZE <b>A</b>	G.O. <b>SDN0301918</b>	ITEM <b>005</b>	SHEET <b>1 OF 4</b>	

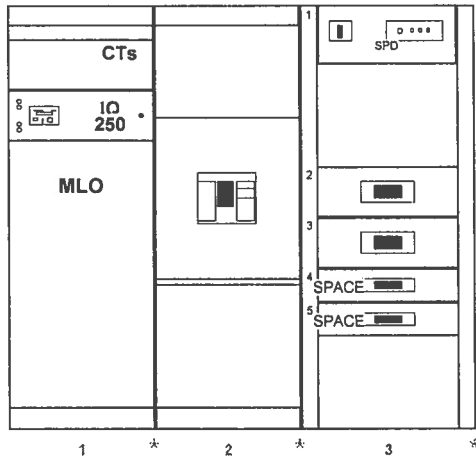

Front View

Power Flow

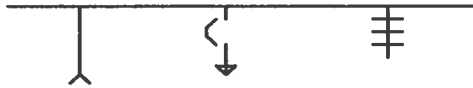

Floor Plan

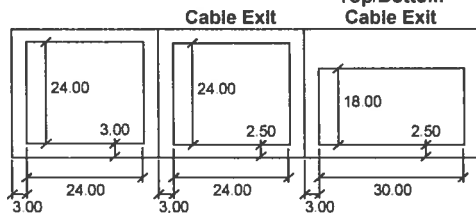

See 1A32043 For  
Floor Plan Detail  
Top/Bottom  
Cable Exit

Total of 3 Structures, Total Width of 96 Inches

Total of 3 Structures, Total Weight of 2011 Weight-Lbs.

Width-Inches	30.00	30.00	36.00		
Width-MM	762	762	914		
Depth-Inches	30.00	30.00	30.00		
Depth-MM	762	762	762		
Height-Inches	90.00	90.00	90.00		
Height-MM	2286	2286	2286		
Weight-Lbs.(Est.)	860	102	1049		
Weight-Kg.(Est.)	390	46	475		
The information on this document is created by Eaton Corporation. It is disclosed in confidence and it is only to be used for the purpose in which it is supplied.	PREPARED BY Fitzgerald, Michael F	DATE 01/21/12	Eaton Corporation Sumter, SC		
	APPROVED BY	DATE	JOB NAME HDT RWRF	DESIGNATION MDP-1	
	VERSION 7.8		TYPE Switchboards	DRAWING TYPE Customer Appr.	
NEG-ALT NUMBER DN851005V102-C000	REVISION 1	DWG SIZE A	G.O. SDN0301918	ITEM 005	SHEET 2 OF 4

### Switchboard Units Information

Str#	Unit	Description/Modifications	Nameplate
1		3000 Amp CT's only (3) wired to shorting block 3000 Amp Customer Metering - IQ 250, CTs, With Display IQ 250, CTs, With Display None, None	
2		Feeder Breaker - Ind Mtd-2000A 3P [RD 2000A Frame], Trip 2000 A. RMS310 LSIG Terminals, Mechanical, (6) #4-500 kcmil, Bottom	SWITCHBOARD EDB-1 MDS #1
3	1	Surge Protective Device -SPD Series 400kA SPD, Standard w/ Surge Counter (Disconnect Included)	
	2	Feeder Breaker - Chassis Mtd-1200A 3P [HND 1200A Frame], Trip 1200 A. RMS310 LSIG Terminals, Mechanical, (4) 4/0-500 kcmil	CAPACITOR BANK CAP-1 (SPACE) MDS #2
	3	Feeder Breaker - Chassis Mtd-800A 3P [HMDL 800A Frame], Trip 800 A. RMS310 LSI Terminals, Mechanical, (3) 3/0-400 kcmil	MCC PD-MCCA P & D BUILDING MDS #3
	4	Feeder Breaker - Chassis Mtd-3P [HKD 400A Frame] Space	BUSSED SPACE MDS #5
	5	Feeder Breaker - Chassis Mtd-3P [HKD 400A Frame] Space	BUSSED SPACE MDS #4

<p>The information on this document is created by Eaton Corporation. It is disclosed in confidence and it is only to be used for the purpose in which it is supplied.</p>	PREPARED BY <b>Fitzgerald, Michael F</b>	DATE <b>01/21/12</b>	<b>Eaton Corporation</b> Sumter, SC		
	APPROVED BY	DATE	JOB NAME <b>HDT RWRP</b>	DESIGNATION <b>MDP-1</b>	
	VERSION <b>7.8</b>	TYPE <b>Switchboards</b>	DRAWING TYPE <b>Customer Appr.</b>		
NEG-ALT NUMBER <b>DN851005V102-C000</b>	REVISION <b>1</b>	DWG SIZE <b>A</b>	G.O. <b>SDN0301918</b>	ITEM <b>005</b>	SHEET <b>3 OF 4</b>

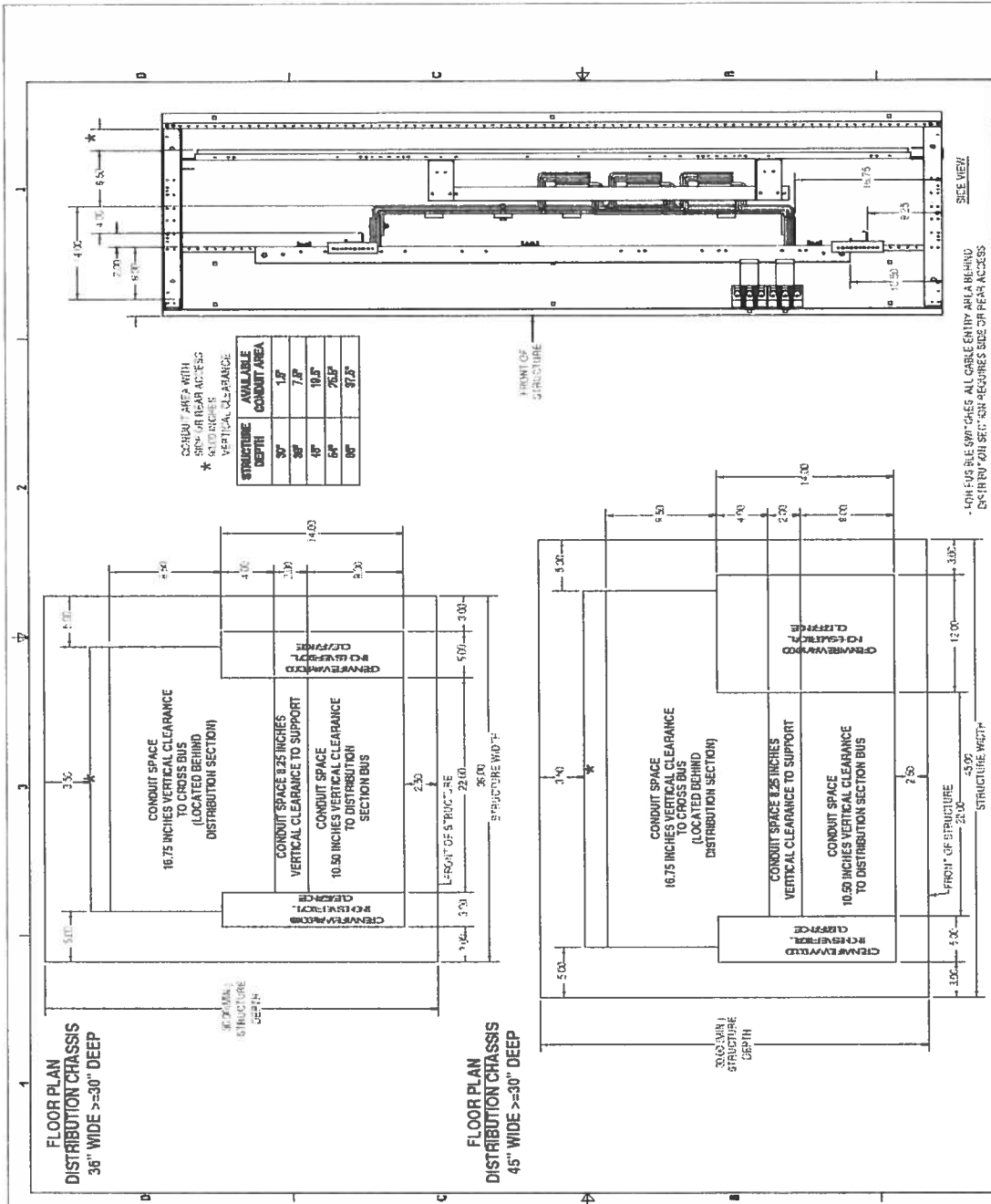

<b>Eaton</b> DISTRIBUTION CHASSIS FLOOR PLAN, 30 DEEP PLAN	
DRAWING NO. 107000 PROJECT NO. 5202000 DATE 01/21/12	REVISION NO. 1 DATE 01/21/12
DRAWN BY MICHAEL FITZGERALD CHECKED BY MICHAEL FITZGERALD APPROVED BY MICHAEL FITZGERALD	PROJECT NO. 3043 SHEET NO. 4 OF 4

The information on this document is created by Eaton Corporation. It is disclosed in confidence and it is only to be used for the purpose in which it is supplied.

PREPARED BY <b>Fitzgerald, Michael F</b>	DATE <b>01/21/12</b>
APPROVED BY	DATE
VERSION <b>7.8</b>	

<b>Eaton Corporation</b>		Sumter, SC
JOB NAME <b>HDT RWRF</b>	DESIGNATION <b>MDP-1</b>	
TYPE <b>Switchboards</b>	DRAWING TYPE <b>Customer Appr.</b>	

NEG-ALT NUMBER <b>DN851005V102-C000</b>	REVISION <b>1</b>	DWG SIZE <b>A</b>	G.O. <b>SDN0301918</b>	ITEM <b>005</b>	SHEET <b>4 OF 4</b>
--------------------------------------------	----------------------	----------------------	---------------------------	--------------------	------------------------

01/21/12

Job Name: HDT RWRF

14:45:35

SDN0301918

**Customer Bill of Material**

1 PRLC Switchboard

- Pow-R-Line C Switchboard, Front Access/ Front and Rear Align, Type 1
- 480Y/277V 3-Phase 4-Wire, 2000 Copper, Minimum Interrupt Rating: 65kA, Bus Bracing Rating: 65kA
- 1 Pow-R-Line C
- 1 2000 Amp CU Main Structure
- 1 Nameplate
- 1 Digitrip RMS310 LSI-RD
- 1 2000A 3P [RD 2000A Frame], Trip 2000 A., RMS310 LSI, (6) #4-500 kcmil, Mechanical, Top

Designations: GEN-1

1 PRLC Switchboard

- Pow-R-Line C Switchboard, Front Access/ Front and Rear Align, Type 1
- 480Y/277V 3-Phase 4-Wire, 2000 Copper, Minimum Interrupt Rating: 65kA, Bus Bracing Rating: 65kA
- 1 Pow-R-Line C
- 1 2000 Amp CU Bussed Incoming Pull Section (Density Rated Bus)
- 1 2000 Amp CU Distribution Structure (Density Rated Bus)
- 1 SPD Series 160kA SPD, Standard w/ Surge Counter (Disconnect Included)
- 1 Digitrip RMS310 LSI-ND
- 12 Nameplate
- 5 Thermal Mag Trip - Standard
- 1 insulated bus
- 1 1200A 3P [HND 1200A Frame], Trip 1200 A., RMS310 LSI, (4) 4/0-500 kcmil, Mechanical
- 2 200A 3P [HFD 225A Frame], Trip 200 A., Thermal Mag, (1) #4-4/0, Mechanical
- 2 70A 3P [HFD 225A Frame], Trip 70 A., Thermal Mag, (1) #14-1/0, Mechanical
- 1 200A 3P [HKD 400A Frame], Trip 200 A., Thermal Mag, (1) 250-500 kcmil, Mechanical
- 6 3P [HFD 225A Frame] Space,

Designations: EDB-1

**All orders must be released for manufacture within 90 days of date of order entry. If approval drawings are required, drawings must be returned approved for release within 60 days of mailing. If drawings are not returned accordingly, and/or if shipment is delayed for any reason, the price of the order will increase by 1.0% per month or fraction thereof for the time the shipment is delayed.**

### Switchboard General Information

**Pow-R-Line C -Specifications**

Quantity: 1  
 Alignment: Front Access/ Front and Rear Align  
 Service: 480Y/277V 3-Phase 4-Wire Minimum Interrupt Rating: 65 kA

**Bus Specifications**

Bus Amps: 2000 Bus Bracing Rating: 65kA  
 Neutral Amps: 2000  
 Bus Material: Copper Heat Test  
 Copper .25 X 1.5 Ground Bus Bolted To Frame, (1) 350 kcmil Ground Lug

**Incoming Information**

Incoming Entry: Bottom Incoming Location: Left  
 Incoming Qty & Size: Terminals, Mechanical, Bottom, (6) #4-500 kcmil

**Structure Specifications**

Non Service Entrance  
 Enclosure Type: Type 1  
 Nameplates: None -

**Enclosure properties**

Struct #	Description/Modifications
1	Bottom incoming/Top outgoing main device (Incoming Main Device/Cable In-Out)

The information on this document is created by Eaton Corporation. It is disclosed in confidence and it is only to be used for the purpose in which it is supplied.

PREPARED BY <b>Fitzgerald, Michael F</b>	DATE <b>01/21/12</b>	<b>Eaton Corporation</b>			
APPROVED BY	DATE	JOB NAME <b>HDT RWRF</b>	Sumter, SC		
		DESIGNATION <b>GEN-1</b>			
VERSION <b>7.8</b>		TYPE <b>Switchboards</b>	DRAWING TYPE <b>Customer Appr.</b>		
NEG-ALT NUMBER <b>DN851005V102-C000</b>	REVISION <b>1</b>	DWG SIZE <b>A</b>	G.O. <b>SDN0301918</b>	ITEM <b>006</b>	SHEET <b>1 OF 3</b>

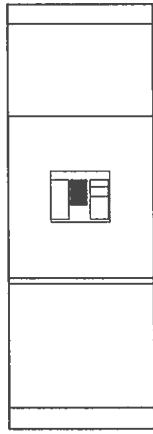

1 \*

Power Flow



Floor Plan

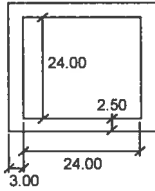

Total of 1 Structures, Total Width of 30 Inches

Total of 1 Structures, Total Weight of 652 Weight-Lbs.

Width-Inches	30.00				
Width-MM	762				
Depth-Inches	30.00				
Depth-MM	762				
Height-Inches	90.00				
Height-MM	2286				
Weight-Lbs.(Est.)	652				
Weight-Kg.(Est.)	295				
The Information on this document is created by Eaton Corporation. It is disclosed in confidence and it is only to be used for the purpose in which it is supplied.	PREPARED BY	DATE	Eaton Corporation		
	Fitzgerald, Michael F	01/21/12	Sumter, SC		
	APPROVED BY	DATE	JOB NAME	HDT RWRF	
			DESIGNATION	GEN-1	
	VERSION		TYPE	DRAWING TYPE	
	7.8		Switchboards	Customer Appr.	
NEG-ALT NUMBER	REVISION	DWG SIZE	G O.	ITEM	SHEET
DN851005V102-C000	1	A	SDN0301918	006	2 OF 3

### Switchboard Units Information

Str#	Unit	Description/Modifications	Nameplate
1		Main Breaker - Ind Mtd-2000A 3P [RD 2000A Frame], Trip 2000 A. RMS310 LSI Terminals, Mechanical, (6) #4-500 kcmil, Top	DISCONNECT GENERATOR FEEDER

<p>The information on this document is created by Eaton Corporation. It is disclosed in confidence and it is only to be used for the purpose in which it is supplied.</p>	PREPARED BY <b>Fitzgerald, Michael F</b>	DATE <b>01/21/12</b>	<b>Eaton Corporation</b>			Sumter, SC
	APPROVED BY	DATE	JOB NAME <b>HDT RWRF</b>	DESIGNATION <b>GEN-1</b>		
	VERSION <b>7.8</b>		TYPE <b>Switchboards</b>	DRAWING TYPE <b>Customer Appr.</b>		
NEG-ALT NUMBER <b>DN851005V102-C000</b>	REVISION <b>1</b>	DWG SIZE <b>A</b>	G. O. <b>SDN0301918</b>	ITEM <b>006</b>	SHEET <b>3 OF 3</b>	



### Switchboard General Information

**Pow-R-Line C -Specifications**

Quantity: 1  
 Alignment: Front Access/ Front and Rear Align  
 Service: 480Y/277V 3-Phase 4-Wire Minimum Interrupt Rating: 65 kA

**Bus Specifications**

Bus Amps: 2000 Bus Bracing Rating: 65kA  
 Neutral Amps: 2000  
 Bus Material: Copper Density Rated Bus - 1000A per square inch  
 Copper .25 X 1.5 Ground Bus Bolted To Frame, (1) 350 kcmil Ground Lug

**Incoming Information**

Incoming Entry: Bottom Incoming Location: Left  
 Incoming Qty & Size: Terminals, Mechanical, Bottom, (6) #4-500 kcmil

**Structure Specifications**

Non Service Entrance  
 Enclosure Type: Type 1  
 Nameplates: None -

**Special Notes**

Qty	Description	Catalog Number
1	insulated bus	CN9077

**Enclosure properties**

Struct #	Description/Modifications
1	Bussed structure with incoming main lugs (Incoming Auxiliary Pull Section) Auxiliary Bus
2	50x chassis mounted feeders (Feeder Structure)

The information on this document is created by Eaton Corporation. It is disclosed in confidence and it is only to be used for the purpose in which it is supplied.	PREPARED BY <b>Fitzgerald, Michael F</b>	DATE <b>01/21/12</b>	<b>Eaton Corporation</b> Sumter, SC		
	APPROVED BY	DATE	JOB NAME <b>HDT RWRF</b>	DESIGNATION <b>EDB-1</b>	
	VERSION <b>7.8</b>		TYPE <b>Switchboards</b>	DRAWING TYPE <b>Customer Appr.</b>	
NEG-ALT NUMBER <b>DN851005V102-C000</b>	REVISION <b>1</b>	DWG SIZE <b>A</b>	G. O. <b>SDN0301918</b>	ITEM <b>007</b>	SHEET <b>1 OF 4</b>

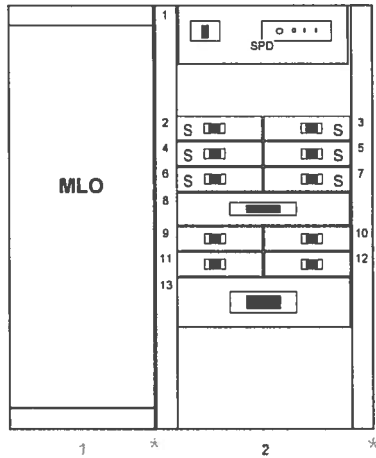

Front View

Power Flow



Floor Plan

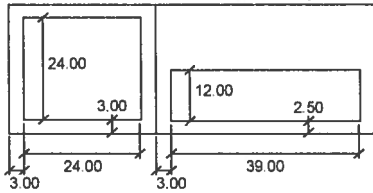

See 1A32043 For  
Floor Plan Detail  
Top/Bottom  
Cable Exit

Total of 2 Structures, Total Width of 75 Inches

Total of 2 Structures, Total Weight of 1599 Weight-Lbs.

Width-Inches	30.00	45.00			
Width-MM	762	1143			
Depth-Inches	30.00	30.00			
Depth-MM	762	762			
Height-Inches	90.00	90.00			
Height-MM	2286	2286			
Weight-Lbs.(Est.)	590	1009			
Weight-Kg.(Est.)	267	457			
The information on this document is created by Eaton Corporation. It is disclosed in confidence and it is only to be used for the purpose in which it is supplied.	PREPARED BY	DATE	Eaton Corporation		
	Fitzgerald, Michael F	01/21/12	Sumter, SC		
	APPROVED BY	DATE	JOB NAME	HDT RWRP	
			DESIGNATION	EDB-1	
	VERSION		TYPE	DRAWING TYPE	
	7.8		Switchboards	Customer Appr.	
NEG-ALT NUMBER	REVISION	DWG SIZE	G.O.	ITEM	SHEET
DN851005V102-C000	1	A	SDN0301918	007	2 OF 4

### Switchboard Units Information

Str#	Unit	Description/Modifications	Nameplate
1			
2			
1		Surge Protective Device -SPD Series 160kA SPD, Standard w/ Surge Counter (Disconnect Included)	
2		Feeder Breaker - Chassis Mtd-3P [HFD 225A Frame] Space	BUSSED SPACE
3		Feeder Breaker - Chassis Mtd-3P [HFD 225A Frame] Space	BUSSED SPACE
4		Feeder Breaker - Chassis Mtd-3P [HFD 225A Frame] Space	BUSSED SPACE
5		Feeder Breaker - Chassis Mtd-3P [HFD 225A Frame] Space	BUSSED SPACE
6		Feeder Breaker - Chassis Mtd-3P [HFD 225A Frame] Space	BUSSED SPACE
7		Feeder Breaker - Chassis Mtd-3P [HFD 225A Frame] Space	BUSSED SPACE
8		Feeder Breaker - Chassis Mtd-200A 3P [HKD 400A Frame], Trip 200 A. Thermal Mag Terminals, Mechanical, (1) 250-500 kcmil	PANELBOARD HW-H1 HEADWORKS BUILDING
9		Feeder Breaker - Chassis Mtd-200A 3P [HFD 225A Frame], Trip 200 A. Thermal Mag Terminals, Mechanical, (1) #4-4/0	PANELBOARD OP-H1 OPERATIONS BUILDING
10		Feeder Breaker - Chassis Mtd-200A 3P [HFD 225A Frame], Trip 200 A. Thermal Mag Terminals, Mechanical, (1) #4-4/0	MCC BS-MCCA BIOSOLIDS BUILDING
11		Feeder Breaker - Chassis Mtd-70A 3P [HFD 225A Frame], Trip 70 A. Thermal Mag Terminals, Mechanical, (1) #14-1/0	PANELBOARD EM-H1 EM BUILDING
12		Feeder Breaker - Chassis Mtd-70A 3P [HFD 225A Frame], Trip 70 A. Thermal Mag Terminals, Mechanical, (1) #14-1/0	GENERATOR NO.1 POWER SUPPLY
13		Feeder Breaker - Chassis Mtd-1200A 3P [HND 1200A Frame], Trip 1200 A. RMS310 LSI Terminals, Mechanical, (4) 4/0-500 kcmil	SWITCHBOARD BB-MDP1 BLOWER BUILDING

<p>The information on this document is created by Eaton Corporation. It is disclosed in confidence and it is only to be used for the purpose in which it is supplied.</p>	PREPARED BY <b>Fitzgerald, Michael F</b>	DATE <b>01/21/12</b>	<b>Eaton Corporation</b> Sumter, SC		
	APPROVED BY	DATE	JOB NAME <b>HDT RWRF</b>	DESIGNATION <b>EDB-1</b>	
	VERSION <b>7.8</b>	TYPE <b>Switchboards</b>	DRAWING TYPE <b>Customer Appr.</b>		
NEG-ALT NUMBER <b>DN851005V102-C000</b>	REVISION <b>1</b>	DWG SIZE <b>A</b>	G.O. <b>SDN0301918</b>	ITEM <b>007</b>	SHEET <b>3 OF 4</b>

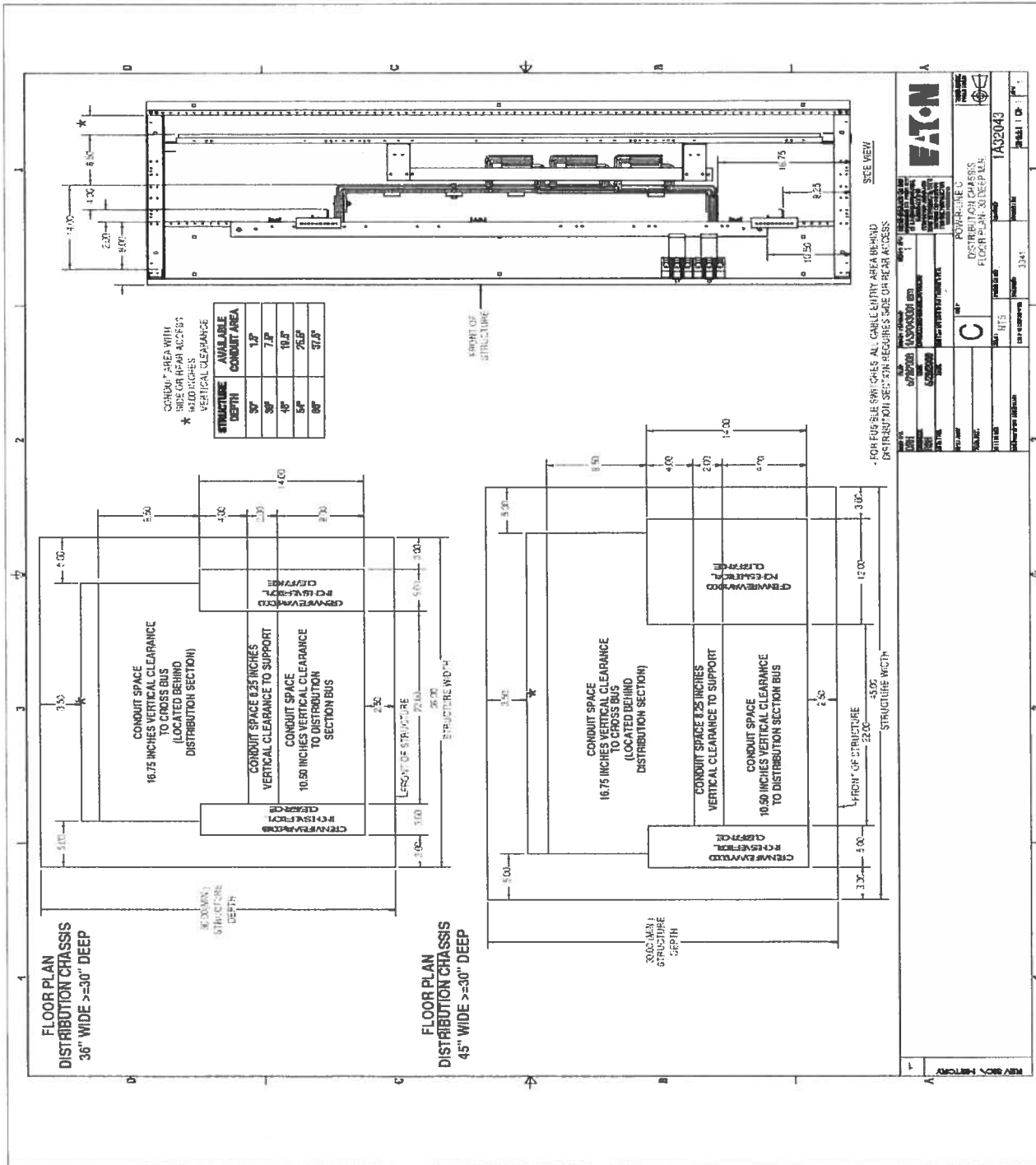

<p>The information on this document is created by Eaton Corporation. It is disclosed in confidence and it is only to be used for the purpose in which it is supplied.</p>	<p>PREPARED BY <b>Fitzgerald, Michael F</b></p>	<p>DATE <b>01/21/12</b></p>	<p><b>Eaton Corporation</b></p>		<p>Sumter, SC</p>
	<p>APPROVED BY</p>	<p>DATE</p>	<p>JOB NAME <b>HDT RWRP</b></p>	<p>DESIGNATION <b>EDB-1</b></p>	
	<p>VERSION <b>7.8</b></p>	<p>TYPE <b>Switchboards</b></p>	<p>DRAWING TYPE <b>Customer Appr.</b></p>		
<p>NEG-ALT NUMBER <b>DN851005V102-C000</b></p>	<p>REVISION <b>1</b></p>	<p>DWG SIZE <b>A</b></p>	<p>G.O. <b>SDN0301918</b></p>	<p>ITEM <b>007</b></p>	<p>SHEET <b>4 OF 4</b></p>

## Pow-R-Line C Switchboards

Meets NEMA Standard PB-2 and UL 891.

### Construction Details

- 6000A main bus maximum
- Front accessible—main sections front- and/or side-access
- Front- and rear-access; main sections front- and/or side-access
- Feeder devices group-mounted
- Sections rear-aligned or front- and rear-aligned

### Main Devices, Individually Mounted

- Molded-case circuit breakers, 400–2500A, fixed-mounted
- Insulated-case circuit breakers, Magnum SB, 800–5000A, fixed and drawout
- Air power circuit breakers, Magnum™ DS, 800–5000A, fixed or drawout
- Air power circuit breakers with current limiting fuses, Magnum DSL, 800–5000A
- Bolted pressure switches, 800–5000A, fixed
- Fusible switches, 400–1200A, fixed

### Feeder Devices, Group-Mounted

- Molded-case circuit breakers, 15–1200A
- Fusible switches, 30–1200A

### Feeder Devices, Individually Mounted

- Molded-case circuit breakers, 800–2500A, fixed
- Insulated-case circuit breakers, Magnum SB, 800–5000A, fixed and drawout
- Air power circuit breakers, DS and Magnum DS, 800–4000A, fixed and drawout
- Bolted pressure switches, 800–1600A, fixed

### Selective Coordination

Selectively coordinated systems dictated by code and customer mandates may be achieved with Eaton switchboards to either 0.1 or 0.01 seconds as mandated by codes and/or customers. Refer to **Tab 1, Section 1.4** for additional details.

**Note:** For selection and layout guidelines, please reference **Page 21.1-1**.

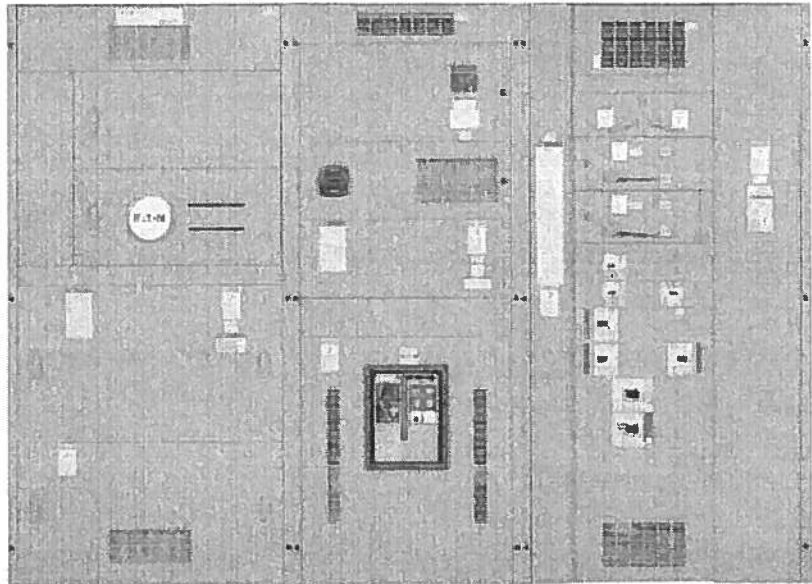

*Pow-R-Line C Switchboard*

For a complete product specification in CSI format, see Eaton's Product Specification Guide ..... **Section 16429**

## General Description—Pow-R-Line C, Front-Access, Group-Mounted Feeders

### Features

- Eaton's circuit breaker ratings up to 200 kAIC
- Trip units that integrate Eaton's Arcflash Reduction Maintenance System™ reduces potential arc flash available
- Integral ground fault protection available in electronic trip units from 15-5000A
- Electronic trip units that integrate zone selective interlocking capabilities available in molded-case, insulated-case and air power circuit breaker
- Available with circuit breakers and fusible switches on the same chassis

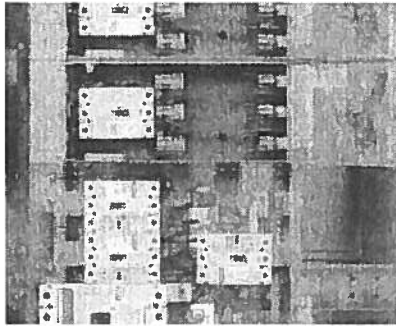

*The Single Chassis Design Provides Device Flexibility*

- UL listed and labeled. Meets NEC and NEMA standards
- Eaton microprocessor-based metering devices are standard when metering is specified. Conventional metering is available. IQ and Power Xpert devices can provide a communications capability. See **Tab 3**
- Optional integral surge protective device (SPD) is available in Pow-R-Line C switchboards, when specified. See **Tab 34**
- Aluminum, copper or silver-plated copper bus
- A full range of device modifications is available
- Available in NEMA Type 1 and 3R enclosures, UL listed

### Modifications

- Ground fault protection on mains and distribution devices
- Coordination with other Eaton divisions for busway and transformer connections

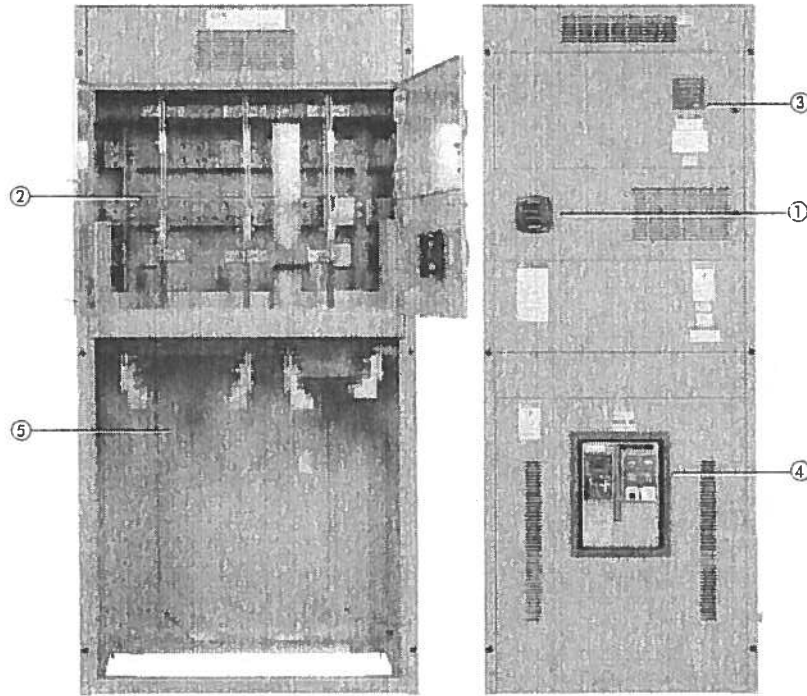

*Type 1 Pow-R-Line C Features*

- ① Customer metering.
- ② Utility metering compartment.
- ③ Surge protective device.
- ④ Main breaker (Magnum SB).
- ⑤ Cable pull and termination space.

**Table 21.0-1. Pow-R-Line C Group-Mounted Switchboards**  
Voltage: 240-480-600 Vac, 250 Vdc  
Mains: 400-6000A

Main Device Type	Amperes	Short-Circuit Symmetrical Rating (kA)
Molded-case circuit breakers	400-2500	14-200
Insulated-case circuit breakers, Magnum SB	800-5000	30-100
Air power circuit breakers, Magnum DS	800-5000	200
Air power circuit breakers with CL fuses, DSL	800-5000	200
Bolted pressure switches	800-5000	200
Fusible switches	400-1200	200
Main lugs only	400-6000	Rating determined by overcurrent protective device

Feeder Device Type	Amperes	Short-Circuit Rating (kA)
Molded-case circuit breakers	15-1200	10-200
Fusible switches	30-1200	200
Stacked—main with branch devices	400-2500	18-200
Magnum SB up to two high	800-2000	30-100
Magnum DS up to two high	800-2000	30-100

- ① 5000A bolted pressure switches are not UL listed.
- ② Third-party witness tested at 30 cycles.

## General Description

## Application Considerations and Definitions

Eaton's Pow-R-Line® family of distribution switchboards incorporates new design concepts that fit the ever-increasing need for applications on high short circuit systems, while retaining maximum flexibility, safety and convenience throughout the line.

### Front Access

Front-access switchboards align at the rear, enabling them to be placed against a wall (Type Pow-R-Line C™ front accessible). If the main section is deeper than others, due to physical size of the main device, the necessary offset in lineup will occur in front, and the main section will be accessible from the side as well as from the front. Eaton also offers front accessible switchboards that align at the front and rear.

### Rear Access

Rear-access switchboards align at the front and the rear. Bus maintenance and cable entry and exit require rear access. There are two types of rear accessible switchboards. Both types use the same incoming utility and/or main structures. The first type uses group-mounted feeder devices with panel construction (Type Pow-R-Line C rear accessible). The second type uses individually compartmentalized feeder devices with load side insulated bus bar extensions (Type Pow-R-Line *i*).

### Individually Mounted

Larger overcurrent protective devices (OCPD) may be individually mounted. In most cases, this means that the OCPD is mounted vertically in the switchboard and is connected via bus bar. All insulated case circuit breakers, power air circuit breakers and bolted pressure contact switches are individually mounted. Molded-case circuit breakers 600A and above may be individually mounted when used as a main or as a feeder device feeding other OCPD within a section or adjacent sections.

### Compartmentalized Feeder and Branch Devices

Compartmentalized molded-case circuit breakers and fusible switches provide additional isolation. Individually mounted molded-case circuit breakers and fusible switches through 1200A are available in a compartmentalized, rear-access,

rear-connected switchboard. See Pow-R-Line *i* switchboards in this section for details.

### Standard Switchboard Height

Standard Pow-R-Line switchboard height is 90.00 inches (2286.0 mm). Contact Eaton for special heights.

### Group Mounting

Group-mounted circuit protective devices are an assembly of units mounted on a panelboard type chassis. Units may be molded-case breakers, fusible switches, customer metering and surge protective devices.

A main molded-case breaker or main fusible switch, within the sizes listed for panelboard design, can be included in the panel-mounted assembly in lieu of a separate, individually mounted unit.

### Space Only for Future Devices Group-Mounted Construction

Where space only for future circuit protective devices is required, the proper space and a blank filler plate will be supplied. Connections and mounting hardware are not included.

### Provision for Future Devices

Where provisions for future circuit protective devices are required, space for the device, corresponding vertical bus, device connectors and the necessary mounting hardware will be supplied.

### Bus Bar System

Standard bus in the switchboards is tin-plated aluminum. Copper, silver-plated copper or tin-plated copper are also available.

Main bus and sub-main buses meet UL® and NEMA® standards for temperature rise on all Pow-R-Line switchboards. Special density rated bus is available.

### Overcurrent Devices

To properly select and size overcurrent devices for use in a switchboard, the allowable temperature rise must be taken into account as to its effect on the tripping characteristics of the devices in question per UL 891.

Accordingly, the NEC® requires overcurrent devices to be rated not less than 125% of the continuous load they are protecting. To comply with this, an 80% derating factor must be used with all overcurrent devices such as molded-case

breakers and FDPW fusible switches unless they are tested and listed for application at 100% of the rating. All Magnum type breakers and bolted pressure switches are 100% rated.

### Short-Circuit Rating

Standard bus and connectors on all switchboards are rated for use on systems capable of producing up to 65,000A rms symmetrical short-circuit current at the incoming terminals.

Increased bus short-circuit ratings equal to that of connected switchboard devices, up to 200,000A rms symmetrical, are available in most Pow-R-Line C switchboards when approved main devices are installed. UL labeled switchboard sections are marked with their applicable short-circuit rating.

When air power circuit breakers are used as feeder devices in a switchboard, these devices may experience up to a 30-cycle (1/2 second) delay if the instantaneous setting is turned off. Eaton has qualified our low voltage switchboards when air power circuit breakers are used as feeders (and mains) to 30 cycles. This rating is not recognized under the UL 891 standard. However, Eaton has witness tested the structure bussing with a qualified National Recognized Testing Laboratory (NRTL) at 30 cycles (1/2 second) up to 100 kAIC symmetrical.

### Provision for Busway Entrance and Exit

Busway connections to switchboard sections include cutout and drilling in the top of the switchboard with riser connections from the switchboard device or bus, up to the point where the bus duct enters the switchboard. No connections are furnished external to the switchboard.

**In all transactions involving busway attached to switchboards, it is essential that information regarding orientation of the busway with respect to the front of the switchboard be supplied to the coordinating assembly plant.**

On Pow-R-Line C switchboards, a solid bus bar is used to connect the bus duct to the individually mounted main device, main or sub-main switchboard bus, or vertical main bus of panel-mounted circuit protective device panels. **Busway fed by group-mounted branch devices are cable connected.**

Aluminum riser connections are standard. Copper- or silver-plated copper is available as an option.

**General Description**

**Transitions**

Transition structures are required for connecting switchboards to the secondary of power center transformer (fluid filled), motor control centers, and for other special switchboard configurations such as "L" or "U" shaped lineups. In some applications, an extra structure complete with connections is required; in others, where switchboard depth and space permit, only the connection conductors are required. Refer to Eaton for these applications.

**Auxiliary Structures**

These are normally mounted adjacent to service structures or distribution structures, and used where incoming service or feeder conductors require additional space or facilities not included in the standard switchboard, such as:

1. Mounted adjacent to a top connected service structure and used as a cable pull structure where service conductors are brought in underground. Auxiliary structures are the same depth and height as the service structure, and are wide enough to accommodate the incoming cables.
2. Mounted adjacent to a service structure and used as a bus transition compartment for running riser bus from the load-side of the service structure up to top outgoing bus duct connection when distribution structures are not required. Auxiliary structures are the same depth and height as service structures.

In addition to the above applications, auxiliary structures may be mounted adjacent to a distribution structure and used as a structure for lighting panel or other device that may be cable-connected to a branch circuit device in the distribution structure. Dimensions are compatible with the arrangements required.

**Switchboards Used as Service Equipment**

Service equipment is the electrical equipment that constitutes the main control and means of power cutoff the electric service (normally Power Company supply) brought into the building.

Where switchboards are to be used as service equipment, certain NEC and UL requirements apply that necessitate modifications not normally supplied in switchboards.

The following is a summary of the requirements that are pertinent to the application of a switchboard for service equipment:

- A. A switchboard with main lugs only (no main disconnect) must be designed so that all circuits in the switchboard can be disconnected from the supply source by the operation of no more than six operating handles (breaker or switch).

Switchboard equipped with main disconnect devices are not subject to the above six disconnect limitation, as the entire board can be de-energized with the main disconnect device.

Ground fault protection of equipment must be provided for solidly grounded wye electrical services of more than 150V to ground, but not exceeding 600V phase-to-phase for each service disconnecting means rated 1000A or more.

- B. For testing purposes, means are also required to disconnect the switchboard neutral bus from the grounded service neutral conductor (single-phase, three-wire; and three-phase, four-wire systems). To comply with this requirement, a removable link (solid bar) is provided in the switchboard neutral bus. This link is generally located near the point where the main feeders enter the switchboard or in the area of the main disconnect device where one is provided.

To further comply with NEC and UL requirements, a separate bonding strap is connected from the neutral bus to the switchboard frame. This bonding connection is located on the line side of the removable neutral link, maintaining a service ground to the switchboard frame when the test link is removed. See Figure 21.0-1.

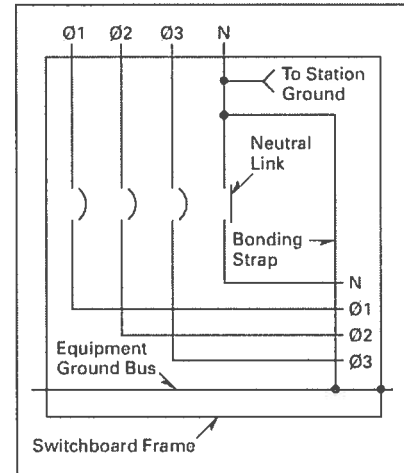

**Figure 21.0-1. Neutral Link**

UL labeling will clearly indicate service equipment listed switchboards.



## General Description

**Underwriters Laboratories Requirements and Labeling**

The basic requirement for obtaining a UL label on a switchboard, is that all the component devices (breakers, switches, and so on) in the switchboard assembly are UL listed. In addition, the switchboard must comply with all applicable provisions of UL 891.

Today's modern electrical systems require that switchboards offer a wide selection of electrical devices, many of which do not fall within the scope of UL listed devices. Therefore, the conditions under which a switchboard may be labeled are limited.

Listed below are several important guidelines for consideration when a UL label is specified:

1. UL nameplates, where applicable, are supplied for each vertical structure rather than one common nameplate for the complete switchboard lineup. Where all of the component devices in the switchboard are UL listed and all applicable provisions of UL 891 are met, each of the switchboard sections may be labeled.
2. Individual vertical structures of a switchboard may be labeled where they comply with UL requirements, although other vertical structures in the same switchboard lineup may not meet the UL standards, and will not be labeled.
3. All Pow-R-Line C switchboards are UL labeled when all mounted devices are UL listed.

**Alternate Power Source Capabilities**

Multiple solutions are available to accommodate alternate power sources available. Due to the large number of customer and system requirements, details are not provided in this guide. Eaton offers solutions that include main-main configuration and main-tie-main configurations. Automatic transfer equipment, including UL 1008 listed transfer switches and other automatic transfer schemes, are available.

**Automatic Transfer Equipment**

For continuity of service, automatic transfer equipment between two incoming sources may be required. This equipment transfers the load upon failure of the normal (or preferred) source to the standby (or alternate) source. Upon restoration of the normal source, the load is automatically transferred back to it. To accomplish this, electrically operated main protective devices (and bus tie devices, if required) must be employed. Additional relays also are required to detect source voltage failure and to transfer control power, when required. A manual selector switch is usually provided to select the mode of operation—automatic or manual transfer.

**Seismic Qualification**

Refer to **Tab 1** for information on seismic qualification for this and other Eaton products.

## General Description

## General Description

General Circuit  
Breaker Information

Eaton's molded-case circuit breakers are designed to provide circuit protection for low voltage distribution systems. They are described by NEMA as, "... a device for closing and interrupting a circuit between separable contacts under both normal and abnormal conditions," and furthermore as, "... a breaker assembled as an integral unit in a supporting and enclosing housing of insulating material." The NEC® describes them as, "A device designed to open and close a circuit by non-automatic means, and to open the circuit automatically on a predetermined overload of current, without injury to itself when properly applied within its rating."

So designed, Eaton circuit breakers protect conductors against overloads and conductors and connected apparatus, such as motors and motor starters, against short circuits.

Circuit Breaker Components  
and Functions

Being essentially high interrupting capacity switches with repetitive elements, Eaton circuit breakers are comprised of three main functional components. These are:

1. Trip elements (thermal-magnetic or electronic)
2. Operating mechanism
3. Arc extinguishers

## 1. Trip Elements

The function of the trip element is to trip the operating mechanism in the event of a prolonged overload or short-circuit current. To accomplish this, a thermal-magnetic trip action is provided.

## Thermal-Magnetic Breakers

Eaton thermal-magnetic breakers are general purpose devices suitable for the majority of breaker applications and are considered the industry standard. Available from 15–800A, thermal-magnetic breakers provide accurate reliable overload and short-circuit protection for conductors and connected apparatus.

Thermal trip action is achieved through the use of a bimetal heated by the load current. On a sustained overload, the bimetal will deflect, causing the operating mechanism to trip. Because bimetals are responsive to the heat emitted by the current flow, they allow a long-time delay on light overloads, yet they have a fast response on heavier overloads.

Magnetic trip action is achieved through the use of an electromagnet in series with the load current. This provides an instantaneous tripping action when the current reaches a predetermined value. Front-adjustable magnetic trip elements are supplied as standard on 250A frame circuit breakers and above (except 100A and 150A magnetic only breakers), all other thermal-magnetic breakers have non-adjustable magnetic trip elements.

## Electronic RMS Trip Breakers

Eaton electronic trip breakers are generally applied for applications where high levels of system coordination are called for. Available from 20–2500A, today's electronic trip breakers can provide superior protection and coordination as well as system alarms and diagnostics, monitoring and communications.

Both the overload trip action and the short-circuit trip action of breakers with Digitrip electronic trip units are achieved by the use of current transformers and solid-state circuitry that monitors the current and initiates tripping through a flux shunt trip when an overload or a short circuit is present. All multiple-pole circuit breakers have trip elements in each pole and a common trip bar. An abnormal circuit condition in any one pole will cause all poles to open simultaneously.

Electronic RMS trip breakers can include trip features such as:

- Adjustable long-time pickup
- Adjustable short-time pickup
- Adjustable long delay time
- Adjustable short delay time
- Adjustable instantaneous pickup
- Adjustable ground fault pickup
- Adjustable ground fault delay time
- Zone selective interlocking
- Communications

Trip unit adjustments are made by setting switches on the front of the trip unit or by programming the trip unit electronically.

All electronic RMS trip breakers are equipped with a manual push-to-trip mechanism.

## 2. Operating Mechanism

The function of the operating mechanism is to provide a means of opening and closing the breaker contacts. All mechanisms are of the quick-make, quick-break type and are "trip free." "Trip free" mechanisms are designed so that the contacts cannot be held closed against an abnormal circuit condition and are sometimes referred to as an "overcenter toggle mechanism." In addition to indicating whether the breaker is "on" or "off," the operating mechanism handle indicates when the breaker is "tripped" by moving to a position midway between the extremes. This distinct trip point is particularly advantageous where breakers are grouped, as in panelboard applications, because it clearly indicates the faulty circuit. The operating mechanism contains a positive on feature. In the normal switching operation, the handle of the circuit breaker will not be capable of being left readily at or near the off position when the main contacts are closed.

## 3. Arc Extinguishers

The function of the DE-ION® arc extinguisher is to confine, divide and extinguish the arc drawn between opening breaker contacts. It consists of specially shaped steel grids isolated from each other and supported by an insulating housing. When the contacts are opened, the arc drawn induces a magnetic field in the grids, which in turn draws the arc from the contacts and into the grids. The arc is thus split into a series of smaller arcs and the heat generated is quickly dissipated through the metal. These two actions result in a rapid removal of ions from the arc, which hastens dielectric build-up between the contacts and results in rapid extinction of the arc.

**Electronic RMS Trip Unit**

**General**

Eaton offers the most comprehensive range of electronic trip units in the industry for molded-case circuit breakers. All electronic trip units are rms sensing and can be applied from 70A up through 2500A. Eaton offers electronic trip units as standard for circuit breakers rated above 800A, and offers electronic trip units as optional for circuit breakers 70A up through 800A.

Digitrip electronic trip units are AC devices that employ microprocessor-based technology that provides a true rms current sensing means for proper correlation with thermal characteristics of conductors and equipment. The primary function of the Digitrip electronic trip unit is to provide circuit protection. This is achieved by analyzing the secondary current signals received from the circuit breaker current sensors and initiating trip signals to the circuit breaker shunt trip when pre-set current levels and time delay settings are exceeded. All Eaton electronic trip units use a high effective sampling rate to maintain measurement accuracy, monitoring, and protection with nonlinear loads having harmonic content up to the 27th order.

Electronic trip units are applied to distribution systems when high standards of protection and coordination are called for. In addition, electronic trip units can provide further enhanced features such as alarming, diagnostics, system monitoring and communications.

Eaton RMS sensing trip units fall into two main categories:

- Front adjustable trip units (Digitrip™ RMS 310, 310+, 510, 610, 810 and 910)
- Programmable trip units (Digitrip OPTIM™ 550 and 1050)

**Front-Adjustable Trip Units**

Front-adjustable trip units are electronic trip units that have up to nine time-current setting options that are set by switches mounted on the front of the trip unit. The application for front adjustable trip units would be distribution systems that can be coordinated within the range of settings available and that do not require sophisticated coordination strategies to be applied down through the distribution system to small rated breakers.

**Programmable Trip Units (OPTIM)**

Programmable trip units are electronic trip units that have up to 10 time-current setting options that are programmed electronically by the use of a programming device. The application for programmable trip units would be high integrity distribution systems that require superior levels of system coordination coupled with system alarming, diagnostics and monitoring.

**Rating Plugs**

Rating plugs provide a means to establish the breaker's continuous current rating. Rating plugs are color-coded and interchangeable to make it easy to match the correct rating plug with the correct trip unit. The same rating plug can be applied to both 50 and 60 Hz distribution systems. Some rating plugs are fixed and some have an adjustable range of amperage values for greater flexibility. Digitrip 310, 510, 610, 810 and 910 trip units can be supplied with either a fixed or adjustable rating plug. Digitrip 310+ trip units are equipped with adjustable rating plugs. OPTIM style trip units are furnished with fixed rating plugs but have a programmable Long Time Pickup rating to allow application over a range of amperage values.

**Cause of Trip Indication**







All OPTIM and Digitrip 510, 610, 810 and 910 trip units include Cause-of-Trip indication LEDs. Breakers using the RMS 310+ electronic trip unit have the ability to output cause-of-trip information through the test port. The Cause-of-Trip LED module provides trip information via LED indication. The Digiview and Panelmount Digiview can be installed in the RMS 310+ test port to provide both cause-of-trip information and phase current through an LCD display.

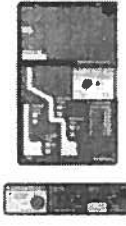

*Cause-of-Trip LED Module*

*Digiview*

**Table 27.1-1. The Digitrip Family of Low Voltage Electronic Trip Units**

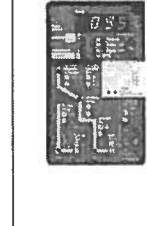
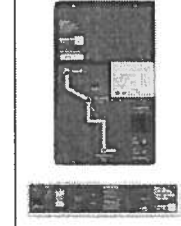
RMS 310	RMS 310+	RMS 510	OPTIM 550	RMS 610	RMS 810	RMS 910	OPTIM 1050
							
rms sensing — 5 functions — Front adjustable	rms sensing — 6 functions — Front adjustable — Optional display for diagnostics and load monitoring — Zone selective interlocking — Optional Arcflash Reduction Maintenance System™	rms sensing — 9 functions — Front adjustable — Zone selective interlocking — Diagnostics	rms sensing — 10 functions — Programmable — Load monitoring — Diagnostics — Zone selective interlocking <sup>1</sup> — Communications <sup>1</sup>	rms sensing — 9 functions — Front adjustable — Zone selective interlocking — Load monitoring — Diagnostics	rms sensing — 9 functions — Front adjustable — Zone selective interlocking — Load monitoring — Diagnostics — Communications — Power and energy monitoring	rms sensing — 9 functions — Front adjustable — Zone selective interlocking — Load monitoring — Diagnostics — Communications — Power and energy monitoring — Harmonics	rms sensing — 10 functions — Programmable — Zone selective interlocking — Load monitoring — Diagnostics — Communications — Power and energy monitoring — Harmonics

<sup>1</sup> Optional features.

**Additional Protection Features**

**Discriminator/Making Current Release**

Eaton's Digitrip RMS electronic trip units are designed and built with safety and reliability in mind, both to protect the user and the equipment, as well as to make sure the trip functions within its design parameters. By providing a discriminator circuit to Digitrip RMS 510, 610, 810 and 910 trip units, as well as to Digitrip OPTIM 550 and 1050 trip units that do not have an instantaneous setting, the user is protected should a faulted circuit exist. The discriminator (or making current releases as it is often called) is set at 11 times the rating plug ampere rating and is enabled for approximately the first 10 cycles of current flow. Should a fault condition exist, the breaker will trip with no intentional time delay on closing, protecting the user from a potentially unsafe condition.

**Instantaneous Override**

In addition to a discriminator, an instantaneous override is present in all molded-case and insulated-case circuit breakers to provide additional protection for the breaker. The instantaneous override is factory set nominally just below the breaker withstand rating.

**Trip Unit Overtemperature**

Digitrip electronic trip units can operate reliably in ambient temperatures that range from -20° to 85°C. In the unlikely event that temperatures exceed this ambient, the trip unit has a built-in overtemperature trip to protect the trip unit should the temperature exceed these design parameters.

**Thermal Memory**

Digitrip RMS and Digitrip OPTIM electronic trip units incorporate powered thermal memory, i.e., the units remember recent overcurrent events that may have initiated the trip timing sequence, and then returned to nominal levels, halting the sequence prior to trip initiation. In the event that the current levels again exceed the pickup set point within a few cycles of the original pickup, the unit's memory recalls the previous near trip and automatically imposes a shorter delay time. In effect, the unit treats multiple time-related events as a single continuous event thereby preventing system damage due to cumulative overheating.

As a further enhancement, the trip units incorporate an unpowered thermal memory feature. In the event that current levels cause the breaker to trip and the breaker is immediately reclosed, the trip unit remembers the previous overcurrent trip and again

imposes a shorter delay time should an additional overcurrent occur before a sufficient cooldown period has elapsed.

Thermal memory protects the distribution system from cumulative overheating caused by repeated overcurrent conditions. OPTIM trip units allow this to be turned ON or OFF.

**System Alarms**

Digitrip RMS 610, 810 and 910 electronic trip units incorporate a high load alarm capability. Set at 85% of I<sub>r</sub>, the alarm will be initiated once the load current exceeds 85% for 40 seconds. Once this occurs, the HILD message will flash in the display window and the power/relay module will operate to send a remote signal.

Digitrip OPTIM electronic trip units also offer a high load alarm capability but with more flexibility. OPTIM trip units have a high load alarm that can be programmed to operate between 50% and 100% of I<sub>r</sub>.

Digitrip OPTIM electronic trip units incorporate a ground fault alarm capability. Settings available for ground fault alarm are the same as for ground fault trip. Once a ground fault alarm occurs, both local and remote signal indication is available (OPTIM 550 is remote only).

## General Description—Trip Units

### System Diagnostics

Whenever a circuit breaker trips, it is normally imperative that the cause of trip be determined quickly, the faulty conditions rectified, and the breaker put back into service. Digitrip RMS 510, 610, 810 and 910, and Digitrip OPTIM electronic trip units incorporate a complete package of systems diagnostics to meet this challenge.

Four cause-of-trip LEDs are embedded in the front of the trip unit case, indicating that the cause-of-trip was either a long delay, short delay, instantaneous or ground fault. Remote signal indication for cause of trip as well as magnitude of trip information is also available.

Breakers using the RMS 310+ electronic trip unit have the ability to output cause-of-trip information through the test port. The Cause-of-Trip LED module provides trip information via LED indication. The Digiview and Panelmount Digiview can be installed to provide both cause-of-trip information and phase current through an LCD display.

### Systems Monitoring

Digitrip RMS and Digitrip OPTIM electronic trip units offer a complete menu of monitoring capability to include current, power and energy, power factor, power quality harmonics, and other related parameters with a high level of accuracy.

### Digital Display

Digitrip RMS 610, 810 and 910 have a large, easy-to-read four-digit alpha-numeric display mounted on the trip unit. The display is supported by LEDs that indicate which parameter is being displayed along with the unit the value is displayed in, e.g., kA and so on.

### Current Monitoring

Digitrip RMS 610, 810 and 910 trip units are capable of monitoring currents in individual phases (A, B, C) as well as ground currents. Digitrip OPTIM 550 and 1050 trip units are capable of monitoring currents in individual phases (A, B, C) as well as neutral and ground currents.

Values are displayed in the digital display window in kA. Accuracy of the current monitored values is  $\pm 2\%$  of full scale sensor rating.

Breakers using the Digitrip 310+ electronic trip unit have the ability to output phase current monitoring information through the test port. The Digiview or Panelmount Digiview can be installed to provide phase current through an LCD display.

For current and voltage monitoring with 0.5% accuracy of reading that can be used with thermal-magnetic or electronic trip units, refer to the Power Monitoring/Metering Module (PM3) on **Page 27.4-41**.

### Power and Energy Monitoring

For the trip unit to calculate true power and energy values, a Potential Transformer Module (PTM) is required. This PTM is mounted internally (R-Frame and larger) or externally (N-Frame or smaller) to the breaker, and provides voltage to the trip unit.

Digitrip RMS 810 and 910 trip units are capable of monitoring peak power demand, present power demand, and reverse power flow in MW. Additionally, both forward and reverse energy consumption in MWh can be monitored. Digitrip OPTIM 1050 trip units can also monitor the same power and energy parameters, but the units are displayed in kW and kWh.

The accuracy of power monitored values is  $\pm 4\%$  of full scale sensor/frame rating.

The accuracy of energy monitored values is  $\pm 5\%$  of full scale sensor/frame rating.

Both the RMS 910 and OPTIM 1050 report power factor. Digitrip RMS 910 trip units have the additional capability of monitoring line-to-line voltage.

For Real Power and Reactive Power monitoring with ANSI C12.1 revenue class accuracy that can be used with thermal-magnetic or electronic trip units, refer to the Power Monitoring/Metering Module (PM3) on **Page 27.4-41**.

### Harmonics Monitoring

Digitrip RMS 910 and Digitrip OPTIM 1050 trip units are capable of monitoring values of current harmonics. Percentage of total harmonic content can be monitored for each level of harmonic content up to the 27th harmonic. Additionally, a total harmonic distortion (THD) value can be calculated and displayed providing the user with total system current harmonic monitoring capability.

**Time-Current Curve Shaping**

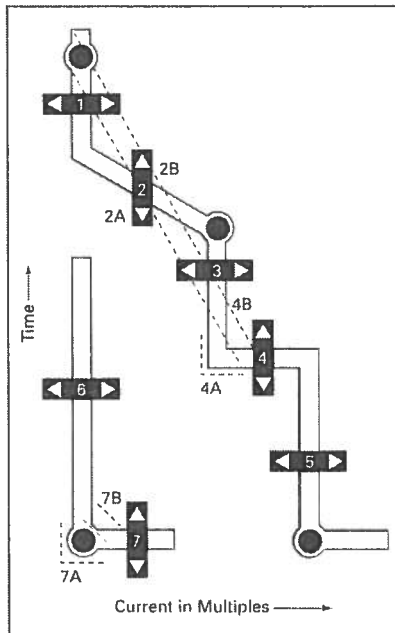

**Figure 27.1-1. Time-Current Curve Shaping**

**Note:** See selection guide charts for availability of adjustments.

**Long Delay (L)**

1. Long Delay Pickup  
Determines the continuous ampere rating of the breaker.
2. Long Delay Time  
Determines the amount of time the breaker will carry a low level overload before tripping.
  - a.  $I^2t$  Response  
 $I^2t$  in: For coordination with other circuit breakers with electronic trip devices and for coordination with thermal-magnetic circuit breakers.
  - b.  $I^4t$  Response  
 $I^4t$  in: For coordination with fuses and upstream transformer damage curves.

**Short Delay (S)**

3. Short Delay Pickup  
Determines or sets the level of fault current at which the short-time trip delay countdown is actuated.
4. Short Delay  
Sets the amount of time the breaker will carry both a low level and high fault currents before tripping.
  - a. Flat Response  
 $I^2t$  out: For coordination with other circuit breakers with electronic trip devices.
  - b.  $I^2t$  Response  
 $I^2t$  in: For coordination with fuses and thermal-magnetic breakers.

**Instantaneous (I)**

5. Instantaneous Pickup  
Determines the level of fault current that will actuate a trip with no time delay.

**Ground Fault (G)**

6. Ground Fault Pickup  
Determines the level of fault current at which the ground fault trip delay countdown is actuated.
7. Ground Fault Delay  
Determines the amount of time the breaker will carry a ground fault before tripping.
  - a. Flat Response  
 $I^2t$  out: For coordination with other circuit breakers with electronic ground fault settings.
  - b.  $I^2t$  Response  
 $I^2t$  in: For coordination with zero sequence ground fault relays, fuses and thermal-magnetic breakers.

**Curve Shaping**

Eaton Digitrip RMS 310 trip units are available with up to five phase and ground adjustments on the front of the trip unit. Digitrip RMS 310+ trip units are available with up to six phase and ground adjustments on the front of the trip unit. Selective system coordination with both upstream and downstream devices can be achieved to provide an economic solution for less sophisticated distribution systems.

For more sophisticated selective coordination systems Digitrip RMS 510, 610, 810 and 910 trip units are available with up to nine curve shaping choices via switches on the front of the unit. Curve shaping flexibility is provided by dependent long and short delay adjustments that are based on continuous amperes ( $I_p$ ) selection.

Digitrip OPTIM 550 and 1050 trip units offer programmable curve shaping via 10 curve shaping choices that are programmed electronically into the trip unit. OPTIM also offers virtual infinite settings to allow the user to optimize coordination for a selectively coordinated distribution system. In addition, time-current set points can be downloaded via a communication system from a central personal computer. Digitrip OPTIM is normally applied to systems where system integrity is very important.

Series C Selection Data—R-Frame

## Series C, R-Frame Electronic RMS, 800–2500A

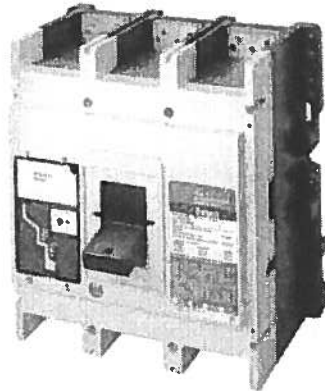

R-Frame Breaker

Table 27.4-85. Dimensions in Inches (mm)

Number of Poles	Width	Height	Depth
3	15.50 (393.7)	16.00 (406.4)	9.75 (247.7)
4	20.00 (508.0)	16.00 (406.4)	9.75 (247.7)

Table 27.4-86. Digitrip 310 Electronic Trip Unit Rating Plugs

Frame	Rating Plugs
1600	800, 1000, 1200, 1250, 1400, 1500, 1600 <sup>①</sup>
2000	1000, 1200, 1250, 1400, 1600, 2000 <sup>①</sup>
2500	1200, 1250, 1600, 2000, 2500 <sup>①</sup>

<sup>①</sup> Adjustable rating plug available.

Table 27.4-87. Digitrip 510/610/810/910 and Digitrip OPTIM Electronic Trip Unit Rating Plugs

Frame	Rating Plugs
1600	800, 1000, 1200, 1600
2000	1000, 1200, 1600, 2000
2500	1600, 2000, 2500

Table 27.4-88. UL 489 Interrupting Capacity Ratings

Circuit Breaker Frame	Number of Poles	Trip Type <sup>②</sup>	Interrupting Capacity (Symmetrical Amperes)			
			Volts AC (50/60 Hz)			
			240	277	480	600
RD	3, 4	N.I.T.	125	—	65	50
CRD <sup>③</sup>	3, 4	N.I.T.	125	—	65	50
RDC	3, 4	N.I.T.	200	—	100	65
CRDC <sup>③</sup>	3, 4	N.I.T.	200	—	100	65

<sup>②</sup> N.I.T. is non-interchangeable trip unit.

<sup>③</sup> 100% rated versions.

Table 27.4-89. Line and Load Terminals

Maximum Breaker Amperes	Terminal Body Material <sup>①</sup>	Wire Type	Hardware	AWG/kcmil Wire Range/Number of Conductors	Metric Wire Range (mm <sup>2</sup> )	Catalog Number
1600	Aluminum	Cu/Al	English	(4) 500–1000 kcmil	300–500	TA1600RD
1600	Copper	Cu	English	(4) 1–600 kcmil	50–300	T1600RD
2000	Aluminum	Cu/Al	English	(6) 2–600 kcmil	35–300	TA2000RD

<sup>①</sup> UL listed for use with copper or aluminum conductors as noted.

**Series C Selection Data—N-Frame**

**Series C, N-Frame**  
**Electronic RMS, 400–1200A**



*N-Frame Breaker*

**Table 27.4-80. Dimensions in Inches (mm)**

Number of Poles	Width	Height	Depth
2, 3	8.25 (209.6)	16.00 (406.4)	5.50 (139.7)
4	11.13 (282.6)	16.00 (406.4)	5.50 (139.7)

**Table 27.4-81. Digitrip 310 Electronic Trip Unit Rating Plugs**

Frame	Rating Plugs
800	400, 450, 500, 600, 700, 800 ①
1200	600, 700, 800, 900, 1000, 1100, 1200 ①

① Adjustable rating plug available.

**Table 27.4-82. Digitrip OPTIM Electronic Trip Unit Rating Plugs**

Frame	Ratings
800	400, 450, 500, 550, 600, 700, 800
1200	600, 700, 800, 1000, 1200

**Table 27.4-83. UL 489 Interrupting Capacity Ratings**

Circuit Breaker Type	Number of Poles	Trip Type ②	Interrupting Capacity (Symmetrical Amperes)			
			Volts AC (50/60 Hz)			
			240	277	480	600
ND, CND ③	2, 3, 4	N.I.T.	65,000	—	50,000	25,000
HND	2, 3, 4	N.I.T.	100,000	—	65,000	35,000
CHND ④	2, 3, 4	N.I.T.	100,000	—	65,000	35,000
NDC	2, 3, 4	N.I.T.	200,000	—	100,000	65,000
CNDC ⑤	2, 3, 4	N.I.T.	200,000	—	100,000	65,000
NDU ⑥	3	N.I.T.	300,000 ⑥	—	150,000	75,000 ⑥

② N.I.T. is non-interchangeable trip unit.

③ 100% rated.

④ 800A maximum rating.

⑤ Successfully tested at 300 kAIC, although UL recognizes maximum of 200 kAIC at 240 Vac.

⑥ Successfully tested at 75 kAIC, although UL recognizes maximum of 65 kAIC at 600 Vac.

**Table 27.4-84. Line and Load Terminals**

Maximum Breaker Amperes	Terminal Body Material ①	Wire Type	AWG/kcmil Wire Range/Number of Conductors	Metric Wire Range (mm <sup>2</sup> )	Catalog Number
-------------------------	--------------------------	-----------	-------------------------------------------	--------------------------------------	----------------

**Standard Cu/Al Pressure Terminals**

700	Aluminum	Cu/Al	(2) 1–500 kcmil	50–300	TA700NB1
1000	Aluminum	Cu/Al	(3) 3/0–400 kcmil	95–185	TA1000NB1
1200	Aluminum	Cu/Al	(4) 4/0–500 kcmil	120–300	TA1200NB1
1200	Aluminum	Cu/Al	(3) 500–750 kcmil	300–400	TA1201NB1

**Optional Copper and Cu/Al Pressure Type Terminals**

700	Copper	Cu	(2) 2/0–500 kcmil	70–300	T700NB1
1000	Copper	Cu	(3) 3/0–500 kcmil	95–300	T1000NB1
1200	Copper	Cu	(4) 3/0–400 kcmil	95–185	T1200NB3

① UL listed for use with copper or aluminum conductors as noted.



Series C Selection Data—M-Frame

Series C, M-Frame  
Electronic RMS, 400–800A  
Thermal-Magnetic, 300–800A



M-Frame Breaker

Table 27.4-75. Dimensions in Inches (mm)

Width	Height	Depth
8.25 (209.6)	16.00 (406.4)	4.06 (103.2)

Table 27.4-76. Thermal-Magnetic Trip Ratings

Frame	Ratings
MDL	300, 400, 450, 500, 600, 700, 800

Table 27.4-77. Digitrip 310 Electronic Trip Unit Rating Plugs

Frame	Rating Plugs
MDL	400, 500, 600, 700, 800, 400/800 adjustable

Table 27.4-78. UL 489 Interrupting Capacity Ratings

Circuit Breaker Type	Number of Poles	Trip Type ①	Interrupting Capacity (rms Symmetrical Amperes)			
			Volts AC (50/60 Hz)			Volts DC ②③
			240	480	600	250
MDL, CMDL ④	2, 3	N.I.T.	65,000	50,000	25,000	22,000
HMDL, CHMDL ④	2, 3	N.I.T.	100,000	65,000	35,000	25,000

- ① N.I.T. is non-interchangeable trip unit.
- ② Two poles or two poles of three pole circuit breaker. Thermal-magnetic trip units only, MDL, HMDL breakers with electronic trip unit are not DC rated.
- ③ Time constant is 3 millisecond minimum at 10 kA and 8 milliseconds minimum at 22 kA.
- ④ 100% rated. Not for use on DC.

Table 27.4-79. Line and Load Terminals

Maximum Breaker Amperes	Terminal Body Material ⑤	Wire Type	AWG/kcmil Wire Range/Number of Conductors	Catalog Number
-------------------------	--------------------------	-----------	-------------------------------------------	----------------

Standard Cu/Al Pressure Terminals

600	Aluminum	Cu/Al	(2) #1–500 kcmil	TA700MA1
800	Aluminum	Cu/Al	(3) 3/0–400 kcmil	TA800MA2
800	Aluminum	Cu/Al	(2) 500–750 kcmil	TA801MA

Optional Copper and Cu/Al Pressure Type Terminals

600	Copper	Cu	(2) 2/0–500 kcmil	T600MA1
800	Copper	Cu	(3) 3/0–300 kcmil	T800MA1

- ⑤ UL listed for use with copper or aluminum conductors as noted.

Series C Selection Data—K-Frame

Series C, K-Frame  
Electronic RMS, 70–400A  
Thermal-Magnetic, 100–400A

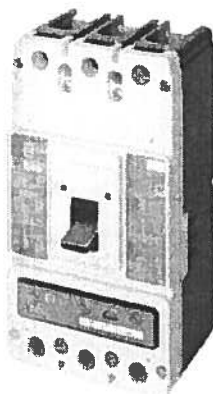

K-Frame Breaker

Table 27.4-64. Dimensions in Inches (mm)

Number of Poles	Width	Height	Depth
2, 3	5.50 (139.7)	10.13 (257.2)	4.06 (103.2)
4	7.22 (183.4)	10.13 (257.2)	4.06 (103.2)

Table 27.4-65. Thermal-Magnetic Trip Ratings

Frame	Ratings
DK, KDB, KD, HKD, KDC, HKDDC,	100, 125, 150, 175, 200, 225, 250, 300, 350, 400

Table 27.4-66. Digitrip 310 and OPTIM Electronic Trip Unit Rating Plugs

Frame	Rating Plugs ①
KD, HKD, KDC, CKD, CHKD	70, 90, 100, 110, 125 ②, 150, 160, 175, 200, 225, 250 ②, 300, 350, 400 ②

① 160A is only available on Digitrip 310.  
② Adjustable rating plug available on Digitrip 310.

Table 27.4-67. NEMA/UL 489/CSA Interrupting Capacity Ratings

Circuit Breaker Type	Number of Poles	Trip Type ③	Interrupting Capacity (Symmetrical Amperes)				
			Volts AC (50/60 Hz)			Volts DC	
			240	480	600	250 ④⑤	600 ⑥
DK	2, 3	N.I.T.	65,000	—	—	10,000	—
KDB	2, 3, 4	N.I.T.	65,000	35,000	25,000	10,000	—
KD	2, 3, 4	I.T.	65,000	35,000	25,000	10,000	—
HKD	2, 3, 4	I.T.	100,000	65,000	35,000	22,000	—
KDC ⑦	2, 3, 4	I.T.	200,000	100,000	65,000	22,000	—
HKDDC	3	I.T.	—	—	—	42,000 ⑧	35,000 ⑨
CKD ⑩	3	I.T.	65,000	35,000	25,000	—	—
CHKD ⑪	3	I.T.	100,000	65,000	35,000	—	—

③ N.I.T. is non-interchangeable trip; I.T. is interchangeable trip.  
④ Two-pole circuit breaker or two outside poles of three-pole circuit breaker.  
⑤ Time constant is 3 milliseconds minimum at 10 kA and 8 milliseconds minimum at 22 kA.  
⑥ 8 milliseconds time constant.  
⑦ Current limiting.  
⑧ 100% rated.  
⑨ Two poles in series.  
⑩ Three poles in series.

Table 27.4-68. Line and Load Terminals

Maximum Breaker Amperes	Terminal Body Material	Wire Type	AWG/Wire Range/Number Conductors	Metric Wire Range (mm <sup>2</sup> )	Catalog Number
-------------------------	------------------------	-----------	----------------------------------	--------------------------------------	----------------

Standard Cu/Al Pressure Terminals

225	Aluminum	Cu/Al	3–350 (1)	35–185	TA300K ⑫
350	Aluminum	Cu/Al	250–500 (1)	120–240	TA350K ⑬
400	Aluminum	Cu/Al	3/0–250 (2)	95–120	2TA400K ⑭⑮ 3TA400K ⑯⑰ 4TA400K ⑱⑲

Optional Copper and Cu/Al Pressure Type Terminals

225	Copper	Cu	3–350 (1)	35–185	T300K ⑲
350	Copper	Cu	50–500 (1)	120–240	T350K ⑳
400	Copper	Cu	3/0–250 (2)	95–120	2T400K ㉑ 3T400K ㉒ 4T400K ㉓
400	Aluminum	Cu/Al	2/0–250 (2) or 2/0–500 (1)	70–120 70–240 70–240	2TA401K ㉔㉔ 3TA401K ㉕㉕ 4TA401K ㉖㉖
400	Aluminum	Cu/Al	500–750 (1)	300–400	2TA402K ㉗㉗ 3TA402K ㉘㉘ 4TA402K ㉙㉙
400	Copper	Cu/Al	500–750 (1)	—	2T402K ㉚㉚ 3T402K ㉛㉛ 4T402K ㉜㉜

⑲ Individually packed.  
⑳ Terminal kits contain one terminal for each pole and one terminal cover.  
㉑ Two-pole kit.  
㉒ Three-pole kit.  
㉓ Four-pole kit.  
㉔ Terminal kits contain one terminal for each pole and three interphase barriers.

Series C Selection Data—F-Frame

Series C, F-Frame  
Thermal-Magnetic 10–225A  
Electronic RMS 15–225A

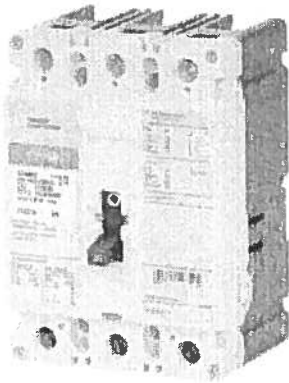

F-Frame Breaker

Table 27.4-55. Dimensions in Inches (mm)

Number of Poles	Width	Height	Depth
1	1.38 (34.8)	6.00 (152.4)	3.38 (85.7)
2	2.75 (69.9)	6.00 (152.4)	3.38 (85.7)
3	4.13 (104.8)	6.00 (152.4)	3.38 (85.7)
4	5.50 (139.7)	6.00 (152.4)	3.38 (85.7)

Table 27.4-56. Thermal-Magnetic Trip Ratings

Frame	Ratings
ED, EDH, EDC	100, 125, 150, 175, 200, 225
EHD, FDB, FD, HFD, FDC, HFDDC	10, 15, 20, 25, 30, 35, 40, 45, 50, 60, 70, 80, 90, 100, 110, 125, 150
FD, HFD, FDC	175, 200, 225

Table 27.4-57. Digitrip 310+ Electronic Trip Units

Types	Frame	Ratings
FDE, HFDE, FDCE	225	100, 110, 125, 150, 160, 175, 200, 225
	160	60, 70, 80, 90, 100, 125, 150, 160
	80	15, 20, 30, 40, 50, 60, 70, 80

Table 27.4-58. UL 489 Interrupting Capacity Ratings

Circuit Breaker Type	Number of Poles	Trip Type ①	Interrupting Capacity (Symmetrical Amperes)						
			Volts AC (50/60 Hz)				Volts DC		
			240	277	480	600	125	250 ②	
EDB	2, 3	N.I.T.	22,000	—	—	—	—	10,000	—
EDS	2, 3	N.I.T.	42,000	—	—	—	—	10,000	—
ED	2, 3	N.I.T.	65,000	—	—	—	—	10,000	—
EDH	2, 3	N.I.T.	100,000	—	—	—	—	10,000	—
EDC ③	2, 3	N.I.T.	200,000	—	—	—	—	10,000	—
EHD	1	N.I.T.	—	14,000	—	—	—	10,000	—
	2, 3	N.I.T.	18,000	—	14,000	—	—	10,000	—
FDB	2, 3, 4	N.I.T.	18,000	—	14,000	14,000	—	—	10,000
FD	1	N.I.T.	—	35,000	—	—	—	10,000	—
FD	2, 3, 4	N.I.T.	65,000	—	35,000	—	—	—	10,000
FDE ④	2, 3, 4	N.I.T.	65,000	—	35,000	18,000	—	—	—
HFD	1	N.I.T.	—	65,000	—	—	—	10,000	—
HFD	2, 3, 4	N.I.T.	100,000	—	65,000	—	—	—	22,000
HFDE ⑤	2, 3, 4	N.I.T.	100,000	—	65,000	25,000	—	—	—
FDC ⑥	2, 3, 4	N.I.T.	200,000	—	100,000	35,000	—	—	22,000
FDCE ⑦	2, 3, 4	N.I.T.	200,000	—	100,000	25,000	—	—	22,000
HFDDC ⑧	3	N.I.T.	—	—	—	—	—	—	42,000 ⑨

① N.I.T. is non-interchangeable trip unit.

② Two-pole circuit breaker, or two poles of three-pole circuit breaker.

③ Time constant is 3 milliseconds minimum at 10 kA and 8 milliseconds minimum at 22 kA.

④ Current limiting.

⑤ Electronics available on three-pole only.

⑥ HFDDC is UL only and is not tested to other standards.

⑦ Interrupting rating is 35,000A at 600 Vdc with three poles in series, for ungrounded systems only.

Table 27.4-59. Line and Load Terminals

Maximum Breaker Amperes	Terminal Body Material ①	Wire Type	AWG Wire Range	Metric Wire Range (mm <sup>2</sup> )	Catalog Number Package of 3 Terminals
-------------------------	--------------------------	-----------	----------------	--------------------------------------	------------------------------------------

Standard Pressure Type Terminals

20 (EHD)	Steel	Cu/Al	(1) #14–#10	2.5–4	3T20FB ②
100	Steel	Cu/Al	(1) #14–1/0	2.5–50	3T100FB
150	Aluminum	Cu/Al	(1) #4–4/0	25–95	3TA150FB
225	Aluminum	Cu/Al	(1) #4–4/0	25–95	3TA225FD

Optional Pressure Terminals

50	Aluminum	Cu/Al	(1) #14–#4	2.5–16	3TA50FB ③
100	Aluminum	Cu/Al	(1) #14–1/0	2.5–50	3TA100FD
150	Stainless Steel	Cu	(1) #4–4/0	25–95	3T150FB
225	Aluminum	Cu/Al	(1) #6–300 kcmil	16–150	3TA225FDK

① UL listed for use with copper or aluminum conductors as noted.

② Not for use with ED, EDH, EDC breakers.

Electronic Trip Units

Electronic Trip Units

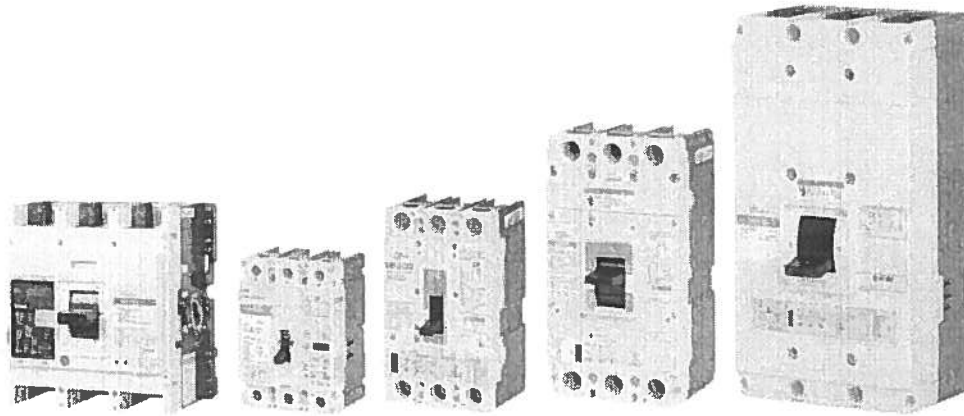

Circuit Breakers with Microprocessor Trip Units

Table 27.4-9. Digitrip RMS Circuit Breaker Trip Unit Selection (See Table 27.4-10 for details)

Description	Digitrip 310	Digitrip 310+	Digitrip 510	OPTIM 550	Digitrip 610	Digitrip 810	Digitrip 910	OPTIM 1050
<b>Circuit Breaker Type</b>								
Molded-case F-Frame 225A		■						
Molded-case JG250-Frame 250A		■						
Molded-case K-Frame 400A	■			■				■
Molded-case L-Frame 600A	LD	■		■				■
	LG		■					
Molded-case M-Frame 800A	■							
Molded-case N-Frame 1200A	ND	■		■				■
	NG		■					
Molded-case R-Frame 2500A	RD	■		■	■	■	■	■
	RG		■					
<b>Features</b>								
Curve shaping functions	5	6	9	10	9	9	9	10
Front adjustable	■	■	■		■	■	■	
Programmable				■				■
Zone selective interlocking		■	■	■ <sup>1</sup>	■	■	■	■
Load monitoring		Option <sup>2</sup>		■	■	■	■	■
Diagnostics (cause-of-trip)		Option <sup>3</sup>	■	■	■	■	■	■
Power/energy monitoring		Option <sup>4</sup>				■	■	■
Harmonics							■	■
Waveform capture							■	■
Communications		Option <sup>4</sup>		■ <sup>1</sup>		■	■	■
Arcflash Reduction Maintenance System (local and remote)		■ <sup>5</sup>						
Ground fault alarm	■ <sup>6</sup>	Option		■ <sup>1,6</sup>	■	■	■	■

1 Optional feature.  
 2 Requires ammeter/cause-of-trip display.  
 3 Requires cause-of-trip LED module or ammeter/cause-of-trip display.  
 4 Requires Power Metering and Monitoring Module (PM3). See Page 27.4-41 for product details.  
 5 Only available in LG, NG and RG breakers.  
 6 Requires auxiliary alarm module below R-Frames.

Note: For time current curves for the trip units, see www.eaton.com.

Electronic Trip Units

Table 27.4-10. Molded-Case Digitrip Selection Guide

Trip Unit Type	Digitrip RMS 310+	Digitrip RMS 310	Digitrip RMS 510	Digitrip RMS 610	Digitrip RMS 810	Digitrip RMS 910	Digitrip OPTIM 550	Digitrip OPTIM 1050	
rms sensing	Yes	Yes	Yes	Yes	Yes	Yes	Yes	Yes	
<b>Breaker Type</b>									
Frame	FDE, JG, LG, NG, RG <sup>(1)</sup>	K, L, M, N, R	R	R	R	R	K, L, N	K, L, N, R	
Ampere range	15-2500A	15-2500A	800-5000A	800-5000A	800-5000A	600-5000A	70-1200A	70-5000	
Interrupting rating at 48V	35, 65, 100, 150 (kA)	35, 65, 100 (kA)	65, 100 (kA)	65, 100 (kA)	65, 100 (kA)	65, 100 (kA)	35, 65, 100 (kA)	35, 65, 100 (kA)	
<b>Protection</b>									
Ordering options	LS LSG	LSI LSIG	LS LSG	LSI LSIG	LI, LS, LSI, LIG, LSG, LSIG	LI, LS, LSI, LIG, LSG, LSIG	LI, LS, LSI, LIG, LSG, LSIG	LSI, LSI (A), LSIG	LSI (A), LSIG
Arclash Reduction Maintenance System	No	ALSI ALSIG <sup>(2)</sup>	No	No	No	No	No	No	
Fixed rated plug (I <sub>N</sub> )	No	Yes	Yes	Yes	Yes	Yes	Yes	Yes	
Overtemperature trip	Yes	Yes	Yes	Yes	Yes	Yes	Yes	Yes	
<b>Long Delay Protection (L)</b>									
Adjustable rating plug (I <sub>N</sub> )	No	Yes	No	No	No	No	No	No	
Long delay pickup	40-100% frame	0.5-1.0(I <sub>N</sub> ) <sup>(3)</sup>	0.5-1.0 x (I <sub>N</sub> )	0.5-1.0 x (I <sub>N</sub> )	0.5-1.0 x (I <sub>N</sub> )	0.5-1.0 x (I <sub>N</sub> )	0.4-1.0 x (I <sub>N</sub> )	0.4-1.0 x (I <sub>N</sub> )	
Long delay time I <sup>2</sup> t	2-24 seconds	10 seconds	2-24 seconds	2-24 seconds	2-24 seconds	2-24 seconds	2-24 seconds	2-24 seconds	
Long delay time I <sup>4</sup> t	No	No	No	No	No	No	1-5 seconds	1-5 seconds	
Long delay thermal memory	Yes	Yes	Yes	Yes	Yes	Yes	Yes	Yes	
High load alarm	No	No	No	0.85 x I <sub>r</sub>	0.85 x I <sub>r</sub>	0.85 x I <sub>r</sub>	0.5-1.0 x I <sub>r</sub>	0.5-1.0 x I <sub>r</sub>	
<b>Short Delay Protection (S)</b>									
Short delay pickup	Varies by frame <sup>(4)</sup>	200-800% x (I <sub>N</sub> )	200-600% S1 and S2 x (I <sub>r</sub> )	200-600% S1 and S2 x (I <sub>r</sub> )	200-600% S1 and S2 x (I <sub>r</sub> )	200-600% S1 and S2 x (I <sub>r</sub> )	150-800% x (I <sub>r</sub> )	150-800% x (I <sub>r</sub> )	
Short delay time I <sup>2</sup> t	Yes	No	100 ms	100-500 ms	100-500 ms	100-500 ms	100-500 ms	100-500 ms	
Short delay time flat	No	Inst-300 ms	No	Inst-300 ms	100-500 ms	100-500 ms	100-500 ms	100-500 ms	
Short delay time Z.S.I.	Yes	No	Yes	Yes	Yes	Yes	Optional	Yes	
<b>Instantaneous Protection (I)</b>									
Instantaneous pickup	No	Varies by frame <sup>(4)</sup>	No	200-800% x (I <sub>N</sub> )	200-600% M1 and M2 x (I <sub>N</sub> )	200-600% M1 and M2 x (I <sub>N</sub> )	200-600% M1 and M2 x (I <sub>N</sub> )	200-800% x (I <sub>N</sub> )	200-800% x (I <sub>N</sub> )
Discriminator	No	Yes	No	Yes <sup>(5)</sup>	Yes <sup>(5)</sup>	Yes <sup>(5)</sup>	Yes <sup>(5)</sup>	Yes	
Instantaneous override	Yes	Yes	Yes	Yes	Yes	Yes	Yes	Yes	
<b>Ground Fault Protection (G)</b>									
Ground fault alarm	Yes	Yes	No	No	No	No	20/25-100% <sup>(6)</sup>	20/25-100% <sup>(7,8)</sup>	
Ground fault pickup	20-100% frame <sup>(6)</sup>	Var/frame <sup>(6)</sup>	25-100% x I <sub>N</sub> <sup>(6)</sup>	25-100% x I <sub>N</sub> <sup>(6)</sup>	25-100% x I <sub>N</sub> <sup>(6)</sup>	25-100% x I <sub>N</sub> <sup>(6)</sup>	20/25-100% <sup>(6)</sup>	20/25-100% <sup>(6)</sup>	
Ground fault delay I <sup>2</sup> t	No	No	100-500 ms	100-500 ms	100-500 ms	100-500 ms	100-500 ms	100-500 ms	
Ground fault delay flat	Inst-300 ms	Inst-500 ms	100-500 ms	100-500 ms	100-500 ms	100-500 ms	100-500 ms	100-500 ms	
Ground fault Z.S.I.	Yes	No	Yes	Yes	Yes	Yes	Optional	Yes	
Ground fault thermal memory	Yes	Yes	Yes	Yes	Yes	Yes	Yes	Yes	
<b>System Diagnostics</b>									
Cause of trip LEDs	No	No	Yes	Yes	Yes	Yes	Yes	Yes	
Magnitude of trip information	No	No	No	Yes	Yes	Yes	Yes	Yes	
Remote signal contacts	No	No	No	Yes	Yes	Yes	No	Yes	
<b>System Monitoring</b>									
Digital display	No	No	No	Yes	Yes	Yes	Yes <sup>(9)</sup>	Yes <sup>(9)</sup>	
Current	No	No	No	Yes	Yes	Yes	Yes	Yes	
Voltage	No	No	No	No	No	No	No	No	
Power and energy	No <sup>(10)</sup>	No <sup>(10)</sup>	No	No	Yes	Yes	No	Yes	
Power quality-harmonics	No	No	No	No	No	Yes	No	Yes	
Power factor	No	No	No	No	Yes (over PowerNet only)	Yes	No	Yes	
<b>Communications</b>									
PowerNet	No	No	No	No	Yes	Yes	Optional	Yes	
<b>Testing</b>									
Testing method	Test kit	Test set	Integral	Integral	Integral	Integral	OPTIMizer, BIM, PowerNet (optional)	OPTIMizer, BIM, PowerNet	

(1) No rating plugs necessary.

(2) Only available on LG, NG and RG breaker.

(3) Adjust by rating plug.

(4) FDE and JG 200-1200% x I<sub>N</sub>  
LG 200-1200% x I<sub>N</sub>  
NG 200-900% x I<sub>N</sub>  
RG 200-800% x I<sub>N</sub>

(5) LS/LSG only.

(6) Not to exceed 1200A.

(7) L- and N-Frames \*20-100% x I<sub>S</sub>.  
R-Frame \*25-100% x I<sub>N</sub>.

(8) By OPTIMizer/BIM.

(9) Yes, with addition of Energy Sentinel.

(10) Yes, with addition of power monitoring/ metering module (PM3).

BIM = Breaker Interface Module

I<sub>S</sub> = Sensor Rating

I<sub>N</sub> = Rating Plug

I<sub>r</sub> = LDPU Setting x I<sub>N</sub>

# Eaton's SPD Series for integration into electrical distribution equipment

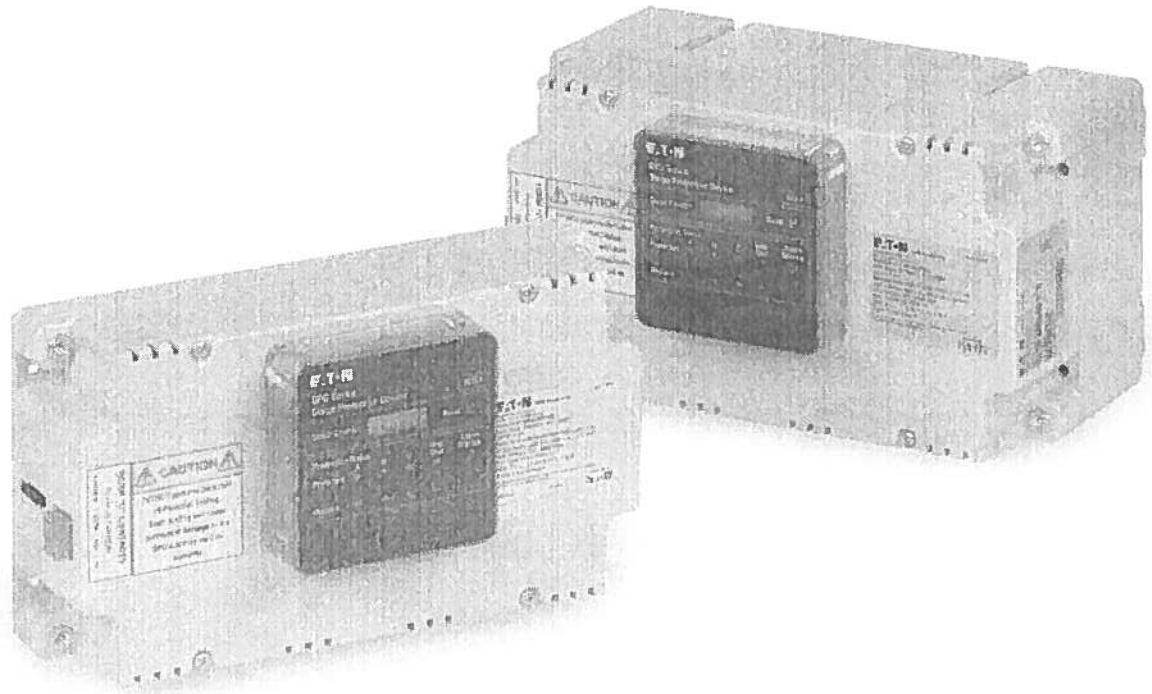

## Contents

Description	Page
Introduction .....	2
Applications .....	2
Features .....	2
Standards and certifications .....	2
Feature package options .....	3
Remote display mounting option .....	3
Dimensions .....	3
Performance data .....	5
Specifications .....	6
Catalog number selection .....	7
Technical support information .....	7



*Powering Business Worldwide*

## Introduction

### Eaton's SPD Series surge protective devices

Eaton's SPD Series surge protective devices are the latest and most advanced UL® 1449 3rd Edition certified surge protectors. Units are available integrated within Eaton electrical assemblies, including panelboards, switchboards, motor control centers, switchgear, and bus plugs. Side-mount versions of the SPD Series are also available for installation external to an electrical assembly. Application of SPD Series units throughout a facility will ensure that equipment is protected with the safest and most reliable surge protective devices available.

SPD Series units are available in all common voltages and configurations and also in a variety of surge current capacity ratings from 50 through 400 kA. Three feature package options are also available to choose from. The breadth of the SPD Series' features, options, and configurations ensures that the correct unit is available for all electrical applications, including service entrances, distribution switchboards, panelboards, and point-of-use applications.

## Applications

The SPD Series is available as an integrated device within the following Eaton electrical assemblies:

- Panelboards
- Switchboards
- Motor control centers
- Switchgear
- Automatic transfer switches
- Bus plugs

## Features

- Uses thermally protected metal oxide varistor (MOV) technology
- 20 kA nominal discharge current ( $I_{n}$ ) rating (maximum rating assigned by UL)
- 50 through 400 kA surge current capacity ratings
- Three feature package options
- 200 kA short circuit current rating (SCCR)
- 10-year warranty

## Standards and certifications



- UL 1449 3rd Edition recognized component for the United States and Canada, covered by Underwriters Laboratories certification and follow-up service

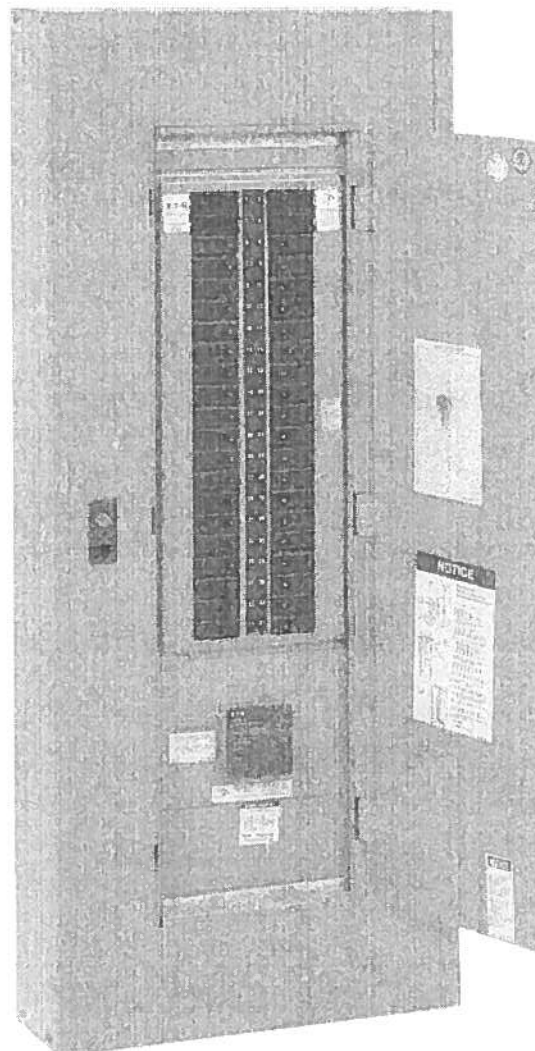

SPD Series Unit Integrated Within an Eaton Panelboard

### Feature package options

The SPD Series provides users with the option of selecting between three feature packages. These feature packages are the basic, standard, and standard with surge counter. The proper feature package can be selected based on the requirements of the application or specification.

**Table 1. Feature Package Comparison**

Feature	Basic	Standard	Standard with Surge Counter
Surge protection using thermally protected MOV technology	✓	✓	✓
Dual-colored protection status indicators for each phase	✓	✓	✓
Dual-colored protection status indicators for the neutral-ground protection mode	✓	✓	✓
Audible alarm with silence button		✓	✓
Form C relay contact		✓	✓
EMI/RFI filtering, providing up to 50 dB of noise attenuation from 10 kHz to 100 MHz		✓	✓
Surge counter with reset button			✓

### Remote display mounting option

The SPD Series offers the option of mounting its display remotely from the device. This is useful for applications where OEMs or other integrators would like to embed the unit within a piece of equipment and still be able to view its display.

SPD Series unit catalog numbers ending with 'B' (refer to catalog number configuration on **Page 7**) should be ordered for applications where the display is to be mounted remotely. These units include the SPD Series unit and the remote display panel.

In addition to the unit itself, a remote display cable will have to be purchased. Remote display cables are available in 4, 8, and 12 foot lengths.

**Table 2. Remote Display Cables**

Description	Catalog Number
4 ft remote display cable	SPDRDCAB04
8 ft remote display cable	SPDRDCAB08
12 ft remote display cable	SPDRDCAB12

**Note:** Integrated units factory-installed with Eaton switchgear assemblies do not require the purchase of a remote display cable. The cable is provided and all required mounting is performed at the factory.

Existing SPD Series units previously installed without a remote display also have the capability of mounting their displays remotely from the device. Complete remote display kits are available that contain all items required to mount the display remotely, including the remote display cable. Remote display kits are available in 4, 8, and 12 foot cable length options.

**Table 3. Remote Display Kits**

Description	Catalog Number
Remote display kit with 4 ft remote display cable	SPDRDKIT04
Remote display kit with 8 ft remote display cable	SPDRDKIT08
Remote display kit with 12 ft remote display cable	SPDRDKIT12

For the dimensions of the cutout required to accommodate the remote display panel, see **Figure 1** below.

### Dimensions

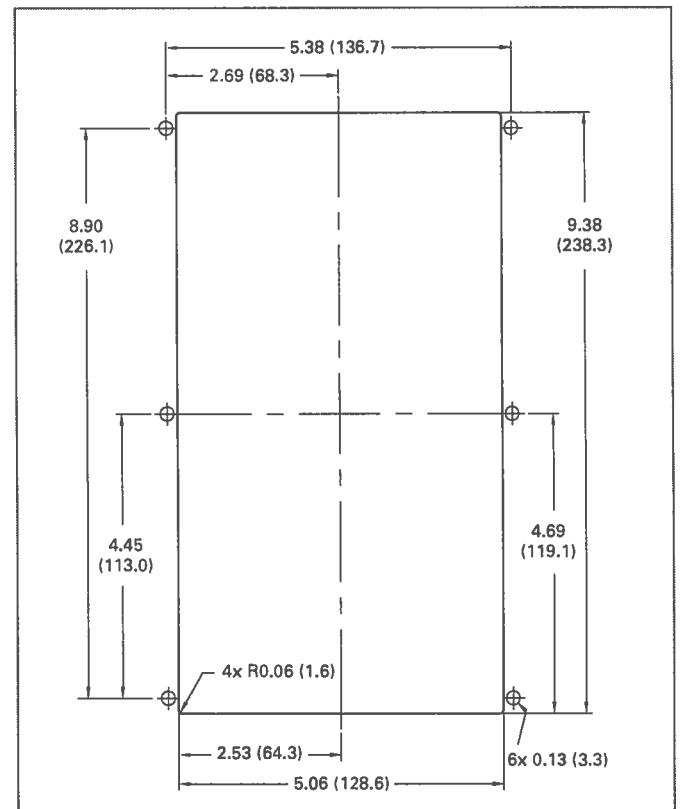

**Figure 1. Dimensions of the Cutout Required to Accommodate the Optional Remote Display Panel**



**Dimensions (continued)**

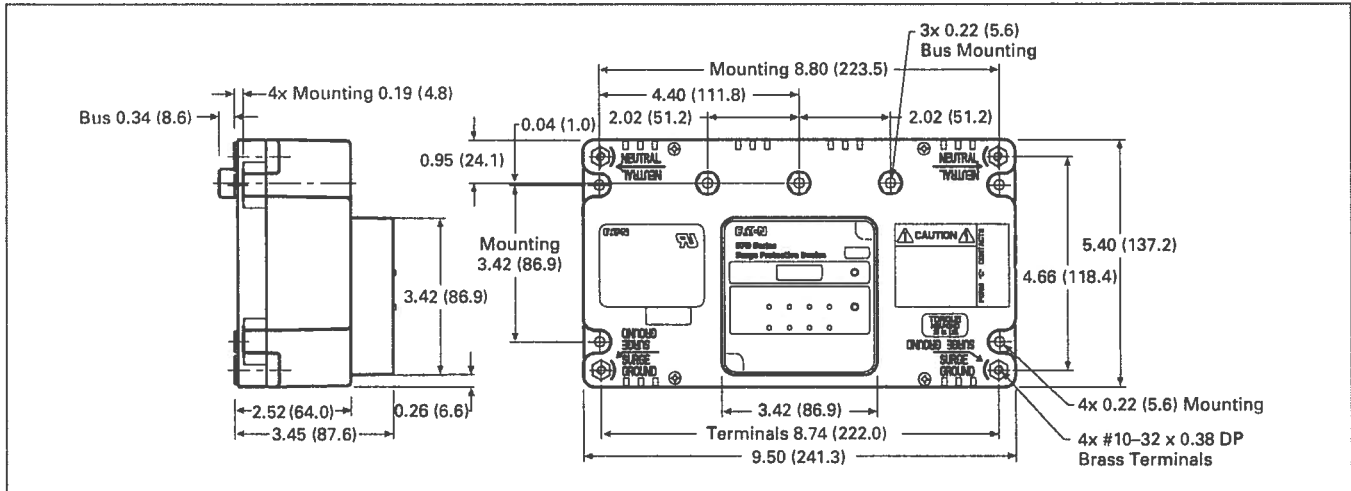

Figure 2. Dimensions of 50 through 200 kA Integrated Units

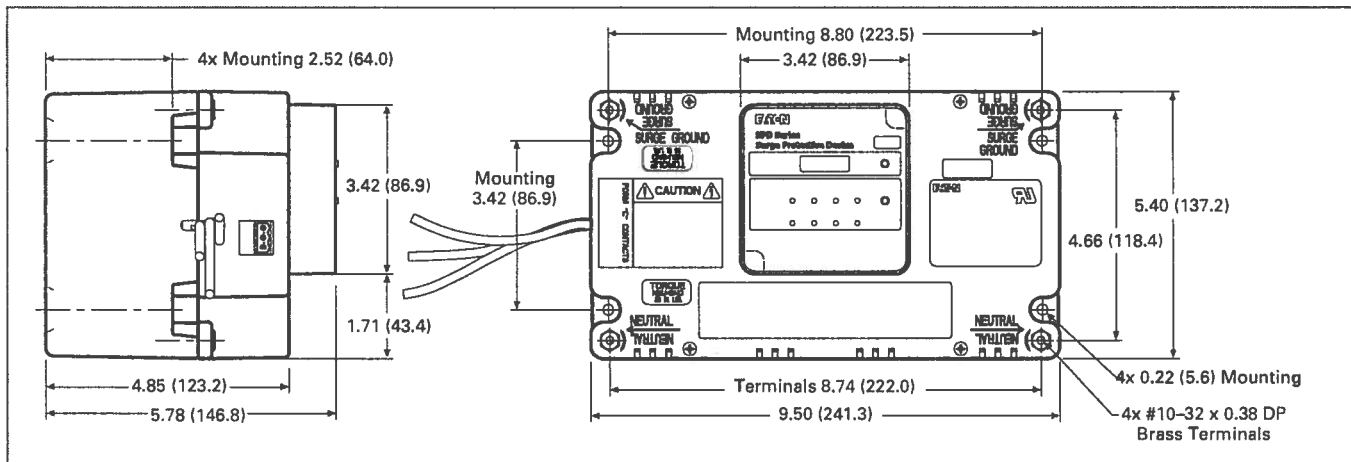

Figure 3. Dimensions of 250 through 400 kA Integrated Units

**Performance data**

**ANSI/UL 1449 3rd Edition voltage protection ratings**

Voltage protection rating (VPR) data is included for both direct bus mounted units (catalog number ending with 'A') and units interfaced to the electrical assembly via a circuit breaker (catalog number ending with 'B,' 'C,' or 'J'). Direct bus mounted units are available for installation within Eaton PRL1a, 2a, 3a, and 3E panelboards only.

**Table 4. 50 kA Direct Bus Mounted Integrated Unit VPR**

Voltage Code	Protection Mode			
	L-N	L-G	N-G	L-L
240S	500	1000	500	1000
208Y and 220Y	500	1000	500	1000
400Y and 480Y	1000	2000	1000	2000
600Y	1200	2500	1200	2500
240D	N/A	1000	N/A	900
480D	N/A	2000	N/A	2000
600D	N/A	2500	N/A	2500
240H	500	1000	500	1000

**Table 5. 80–100 kA Direct Bus Mounted Integrated Unit VPR**

Voltage Code	Protection Mode			
	L-N	L-G	N-G	L-L
240S	500	600	500	900
208Y and 220Y	500	600	500	900
400Y and 480Y	1000	1200	1000	1800
600Y	1200	1500	1200	2500
240D	N/A	1000	N/A	900
480D	N/A	1800	N/A	1800
600D	N/A	2500	N/A	2500
240H	500	600	500	900

**Table 6. 120–200 kA Direct Bus Mounted Integrated Unit VPR**

Voltage Code	Protection Mode			
	L-N	L-G	N-G	L-L
240S	500	600	500	800
208Y and 220Y	500	600	500	800
400Y and 480Y	900	1000	900	1800
600Y	1200	1200	1200	2500
240D	N/A	900	N/A	900
480D	N/A	1800	N/A	1800
600D	N/A	2500	N/A	2500
240H	500	600	500	800

**Table 7. 250–300 kA Circuit Breaker Interfaced Integrated Unit VPR**

Voltage Code	Protection Mode			
	L-N	L-G	N-G	L-L
240S	600Ⓢ	700	600	1000
208Y and 220Y	600Ⓢ	700	600	1000
400Y and 480Y	1000	1200	900	1800
600Y	1500	1500	1200	2500
240D	N/A	1000	N/A	1000
480D	N/A	1800	N/A	1800
600D	N/A	2500	N/A	2500
240H	600Ⓢ	700	600	1000

Ⓢ L-N VPR for 250–300 kA units containing the standard and standard with surge counter feature packages is 600V. L-N VPR for units containing the basic feature package is 700V. All other VPR numbers reported in all tables represent the VPR for all feature packages.

**Table 8. 50 kA Circuit Breaker Interfaced Integrated Unit VPR**

Voltage Code	Protection Mode			
	L-N	L-G	N-G	L-L
240S	700	1200	700	1200
208Y and 220Y	700	1200	700	1200
400Y and 480Y	1200	2000	1200	2000
600Y	1500	2500	1500	2500
240D	N/A	1200	N/A	1200
480D	N/A	2000	N/A	2000
600D	N/A	2500	N/A	2500
240H	700	1200	700	1200

**Table 9. 80–100 kA Circuit Breaker Interfaced Integrated Unit VPR**

Voltage Code	Protection Mode			
	L-N	L-G	N-G	L-L
240S	700	700	700	1000
208Y and 220Y	700	700	700	1000
400Y and 480Y	1200	1200	1200	1800
600Y	1500	1500	1500	2500
240D	N/A	1200	N/A	1200
480D	N/A	2000	N/A	2000
600D	N/A	2500	N/A	2500
240H	700	700	700	1000

**Table 10. 120–200 kA Circuit Breaker Interfaced Integrated Unit VPR**

Voltage Code	Protection Mode			
	L-N	L-G	N-G	L-L
240S	700	700	600	1000
208Y and 220Y	700	700	600	1000
400Y and 480Y	1000	1200	1000	1800
600Y	1500	1500	1200	2500
240D	N/A	1000	N/A	1000
480D	N/A	2000	N/A	1800
600D	N/A	2500	N/A	2500
240H	700	700	600	1000

**Table 11. 400 kA Circuit Breaker Interfaced Integrated Unit VPR**

Voltage Code	Protection Mode			
	L-N	L-G	N-G	L-L
240S	700	700	600	1000
208Y and 220Y	700	700	600	1000
400Y and 480Y	1000	1200	900	1800
600Y	1500	1500	1200	2500
240D	N/A	1000	N/A	1000
480D	N/A	1800	N/A	1800
600D	N/A	2500	N/A	2500
240H	700	700	600	1000

## Specifications

**Table 12. SPD Series Specifications**

Description	Specification
Surge capacity ratings available	50, 80, 100, 120, 160, 200, 250, 300, 400 kA per phase
Nominal discharge current (I <sub>n</sub> )	20 kA
Short circuit current rating (SCCR)	200 kA
SPD type	Basic feature package = Type 1 (can also be used in Type 2 applications) Standard and Standard with Surge Counter feature packages = Type 2
Single split phase voltages available	120/240
Three-phase Wye system voltages available	120/208, 127/220, 230/400, 277/480, 347/600
Three-phase Delta system voltages available	240, 480, 600
Input power frequency	50/60 Hz
Power consumption (basic units): 208Y, 220Y, 240S, 240D, and 240H voltage codes 400Y, 480Y, and 480D voltage codes 600Y and 600D voltage codes	0.5W 1.1W 1.3W
Power consumption (standard and standard with surge counter units): 208Y, 220Y, 240S, 240D, and 240H voltage codes 400Y, 480Y, and 480D basic voltage codes 600Y and 600D voltage codes	0.6W 1.7W 2.1W
Protection modes	Single split phase . . . . . L-N, L-G, N-G, L-L Three-phase Wye . . . . . L-N, L-G, N-G, L-L Three-phase Delta . . . . . L-G, L-L Three-phase high-leg Delta . . . . . L-N, L-G, N-G, L-L
Maximum continuous operating voltage (MCOV): 240S, 208Y, 220Y, and 240H MCOV 400Y and 480Y MCOV 600Y MCOV 240D MCOV 480D MCOV 600D MCOV	150 L-N, 150 L-G, 150 N-G, 300 L-L 320 L-N, 320 L-G, 320 N-G, 640 L-L 420 L-N, 420 L-G, 420 N-G, 840 L-L 320 L-G, 320 L-L 640 L-G, 640 L-L 840 L-G, 840 L-L
Ports	1
Operating temperature	-4°F through 122°F (-20°C through 50°C)
Operating humidity	5% through 95%, noncondensing
Operating altitude	Up to 16,000 ft (5000m)
Seismic withstand capability	Meets or exceeds the requirements specified in IBC <sup>®</sup> 2006, CBC 2007, and UBC <sup>®</sup> Zone 4
Weight	50–200 kA units approximately 3.5 lbs (1.6 kg) 250–400 kA units approximately 7.0 lbs (3.2 kg)
Form C relay contact ratings	150 Vdc or 125 Vac, 1A maximum
Form C relay contact logic	Power ON, normal state—NO contact = open, NC contact = closed Power OFF or fault state—NO contact = closed, NC contact = open
EMI/RFI filtering attenuation	Up to 50 dB from 10 kHz to 100 MHz
Agency certifications and approvals	UL 1449 3rd Edition recognized component for the U.S. and Canada UL 1283 (Type 2 SPDs only)
Warranty	10 years

### Catalog number selection

Table 13. SPD Series Catalog Number Configuration for Units Integrated into Electrical Distribution Equipment

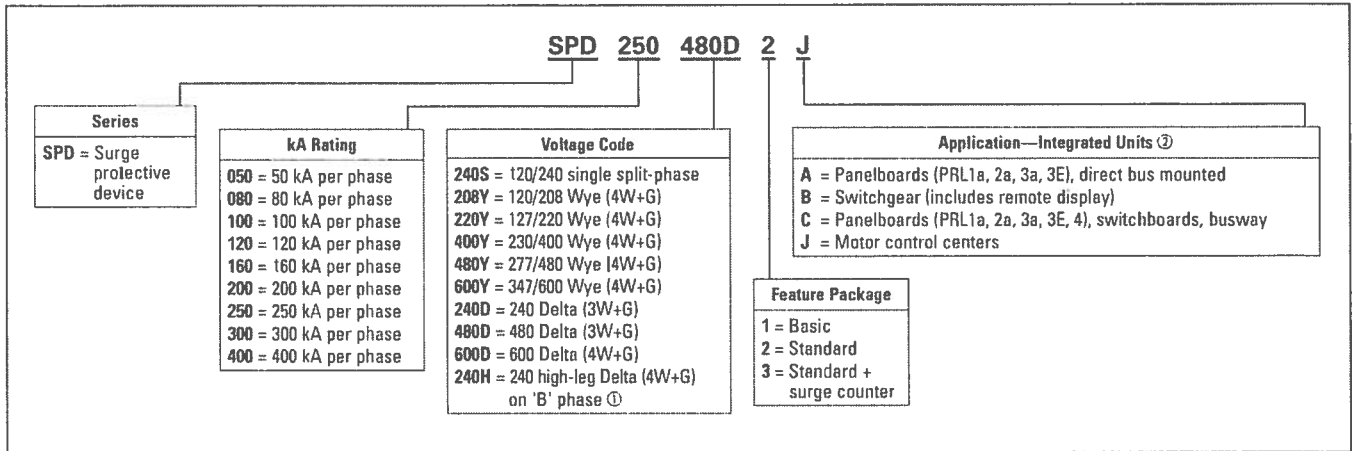

**Example:** SPD250480D2J = SPD Series, 250 kA per phase, 480D voltage, standard feature package, motor control center application

- ① Please consult the factory for 240 high-leg Delta (4W+G) applications with high leg on 'C' phase.
- ② Units used in PRL1a, 2a, 3a, and 3E panelboard applications are available in 50–200 kA ratings only. Use the 'C' option for PRL1a, 2a, 3a, and 3E panelboard applications when unit is connected through a circuit breaker.

### Technical support information

If you have any questions or need additional information, please contact the Eaton Technical Resource Center at 800-809-2772, option 4, option 2. You may also submit inquiries via e-mail: [surgeprotection@eaton.com](mailto:surgeprotection@eaton.com).

**IQ 250 and 260 Electronic Power Meters**



IQ 250/260 Electronic Power Meter

**Product Description**

The IQ 250 and IQ 260 meters provide capabilities you would not normally expect in affordable, ultra-compact meters, such as fast sampling rate and accurate metering for a full range of power attributes. Providing the first line of defense against costly power problems, Eaton's IQ 250 and IQ 260 electronic power meters can perform the work of an entire wall of legacy metering equipment utilizing today's technology.

When space is at a premium, yet you need ANSI C12.20 accuracy, the IQ 250/260 series fit the bill. These meters are ideal for electrical equipment assemblies, machine control panels, such as panelboard and switchboard mains and feeders, low voltage metal-enclosed switchgear feeders and motor control centers. Requiring far less space than other meters with similar functionality, IQ 250/260 series fit into a standard ANSI or IEC cutout on a panelboard or other electrical equipment, and therefore fit easily into retrofit applications.

**Typical Applications**

- Utility and commercial metering.
- Substations, industrial facilities, power generation sites and campuses.
- Sub-metering.
- Load studies and voltage recording.
- Analog meter replacement.

**Features and Benefits**

- Measure and display real-time information about critical power parameters with a sampling rate of 400 samples per cycle.
- Monitor power utilization and quality with ANSI C12.20 accuracy (0.2 percent).
- Verify meter accuracy with KYZ test pulse self-certification capabilities.
- Standard Modbus® RTU communications.
- Available as transducer only or with display.
- "Prepared for the future" — The meters are designed to accommodate upgrades and capabilities not yet conceived.
- Integrate into Eaton's Power Xpert® Architecture for a holistic system-level view.

**Additional Features**

Table 26-9. Features of IQ 250 and IQ 260 Electronic Power Meters

Features	IQ 250	IQ 260
<b>Instrumentation</b>		
Current, per Phase	■	■
Current Demand	■	■
Calculated Neutral Current	■	■
Voltage, per Phase (L-L, L-N)	■	■
Frequency	■	■
<b>Power, Energy and Demand</b>		
Real, Reactive and Apparent Power, Total and per Phase (kW, kvar, kVA)	■	■
Real, Reactive and Apparent Energy, Total and per Phase (kWh, kvarh, kVAh)	■	■
Real, Reactive and Apparent Power Demand	■	■
Power Factor, Total and per Phase	■	■
Min./Max. Readings, I, V, PF, F, THD (IQ 260), kW, kvar, kVA	■	■
<b>Demand Methods</b>		
Block Interval (Sliding, Fixed)	■	■
<b>Communications</b>		
RS-485	■	■
KYZ Output	■	■
Modbus RTU	■	■
Modbus ASCII	■	■
DNP 3.0	■	■
<b>I/O</b>		
2 Digital In / 2 Digital Out <sup>①</sup>	Opt.	Opt.
4 Digital In / 4 KYZ Out	Opt.	Opt.
4 Analog Output (4 – 20 mA) <sup>②</sup>	Opt.	Opt.
4 Analog Output (0 – 1 mA)	Opt.	Opt.
<b>Power Quality Analysis</b>		
Total Harmonic Distortion (THD) Voltage and Current per Phase		■
<b>Alarming</b>		
Set Point Driven Alarm		■

<sup>①</sup> Digital Out with IQ250 requires external command.

<sup>②</sup> Requires external power supply.

## Technical Data and Specifications

**Table 26-10. IQ 250/260 Electronic Power Meter Technical Information**

Description	Specifications
<b>Current Inputs</b>	
Class 10	5 Amp Nominal, 10 Amp Max.
Class 2	1 Amp Nominal, 2 Amp Max.
Fault Current Withstand 100 Amps for: 300 Amps for: 500 Amps for:	10 Seconds 3 Seconds 1 Second
Continuous Current Withstand	20 Amps for Screw Terminated or Pass-through Connections
Programmable Current	Full Scale to Any CT Ratio
Burden	0.005 VA per Phase Max. at 11 Amps
Pickup Current Class 10 Class 2	0.1% of Nominal 5 mA 1 mA
Connections Pass-through Wire Gauge Dimension Quick Connect	0.177 Inches (4.5 mm) 0.25-Inch Male Tab
<b>Voltage Inputs</b>	
Range Line-to-Neutral Line-to-Line	20 – 576 Vac 0 – 721 Vac
Programmable Voltage Range	Full Scale to Any PT Ratio
Supported Systems	3 Element Wye, 2.5 Element Wye, 2 Element Delta, 4-Wire Delta Systems
Input Impedance	1 Meg Ohm/Phase
Burden	0.36 VA/Phase Max. at 600 V; 0.014 VA at 120 Volts
Connection	7-Pin 0.400-Inch Pluggable Terminal Block, AWG #12 – 26 (0.129 – 3.31 mm <sup>2</sup> )
<b>Isolation</b>	
All inputs and outputs are galvanically isolated to 2500 volts.	
<b>Environmental Ratings</b>	
Operating Temperature	-20°C to +70°C
Storage Temperature	-20°C to +70°C
Operating Humidity	To 95% RH Non-condensing
Faceplate Rating	NEMA 12 Water-resistant Mounting Gasket Included

Description	Specifications
<b>Sensing Method</b>	
Voltage, Current	True RMS
Power	Sampling at Over 400 Samples per Cycle On All Channels
Harmonics Resolution	40th Order
<b>Update Rate</b>	
Watts, Var and VA	100 msec at 60 Hz
All Other Parameters	1 Second at 60 Hz
<b>Power Supply</b>	
ac/dc Voltage Option	90 – 265 Vac at 50/60 Hz or 100 – 370 Vdc, Universal ac/dc Supply
dc Voltage Option	18 – 60 Vdc
Burden	10 VA Max.
<b>Standard Communications Format</b>	
Connection Type	RS-485 (Through Back Plate)
Com Port Baud Rate	9600 – 57,600 Bauds
Com Port Address	01 – 247
Data Format	8-Bit, No Parity
Protocols	Modbus ASCII, RTU or DNP 3.0
<b>KYZ Pulse</b>	
Contacts	1 Form A
On Resistance, Max.	35 Ohms
Peak Switching Voltage	350 Vdc
Continuous Load Current	120 mA
Peak Load Current	350 mA (10 ms)
Off-state Leakage Current at 350 Vdc	1 uA
Opto-isolation	3750 Vac
<b>Dimensions and Shipping</b>	
Weight	2 lbs.
Basic Unit	H 5.00 x W 4.90 x L 5.00 Inches
IQ 250/260	Mounts in 92 mm DIN and ANSI C39.1 Round Cut-outs
Shipping Container Dimensions	6-Inch Cube
Tolerance	+/-0.1 Inches (2.54 mm)
<b>Compliance</b>	
IEC 687	0.2% Accuracy
ANSI C12.20	0.2% Accuracy
ANSI C62.41	Burst
UL/cUL	Electrical & Electronic Measuring & Test Equipment 22CZ

**IQ 250/260 Series**

**IQ 250/260 Meter Dimensions**

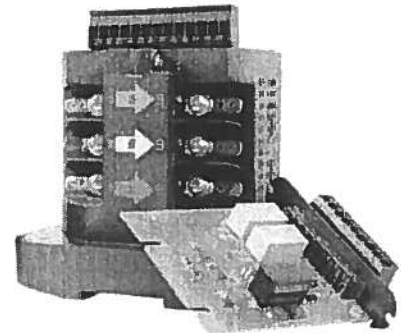
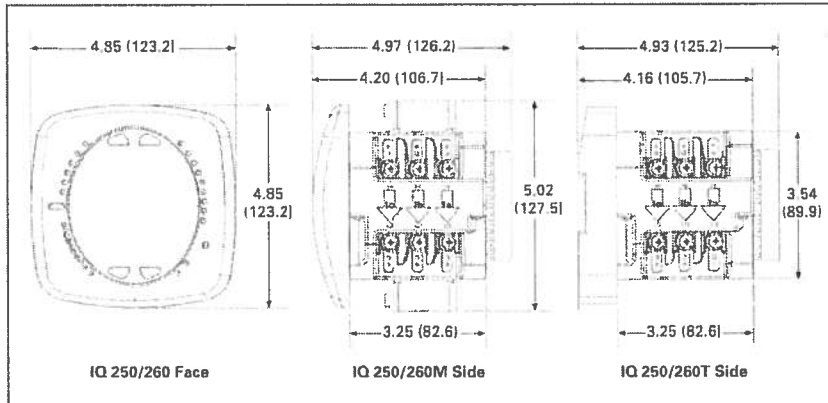

*Expandable I/O Componentry*

Figure 26-27. IQ 250/260 Meter Dimensions — Face and Side Views

**Ordering Information**

Table 26-11. IQ 250/260 Meter Catalog Numbering System

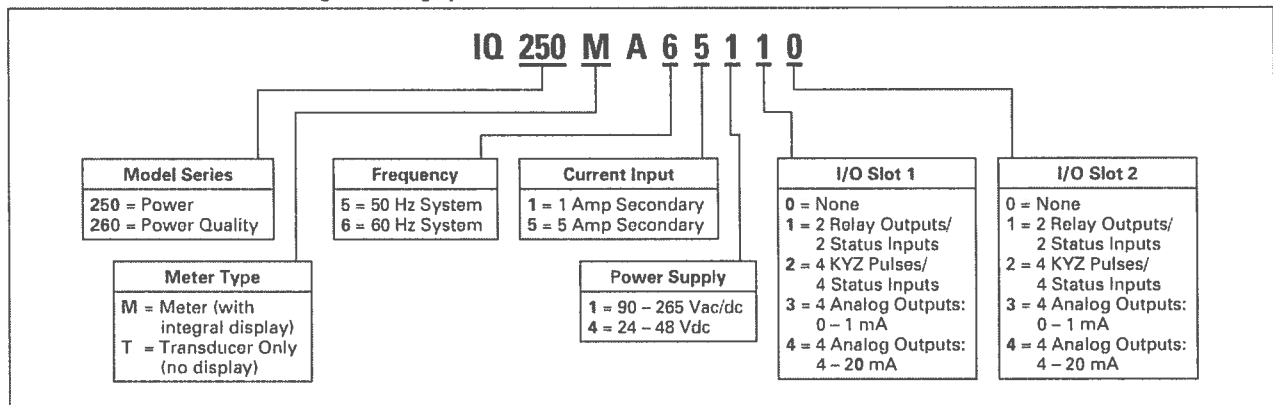

Table 26-12. IQ 250/260 Meter Accessories

Description	Catalog Number
Panel Mounting Adapter for retrofitting an IQ 250/260 to an IQ Analyzer/IQ DP-4000/IQ Data Cutout	Consult Factory
PXM 2000 Gateway Card Kit to upgrade an IQ250/260 to a PXM 2000	PXM2000-GCK







**TAB 2 Panelboards**

# EATON

## Technical Data

01/21/12

Job Name: HDT RWRF  
SDN0301918

14:45:24

**Customer Bill of Material**

- 1 Pow-R-Line1a  
42 Circuits, 225A, Fully Rated, 208Y/120V 3Ph 4W, Copper Bus, 10k AIC,150A, 3P EDB Main Breaker[Top Fed],  
Surface Mounted, Surge Protective Device, 160 kA SPD Series - Standard w/ Surge Counter
  - 1 150A, 3P EDB Main Breaker
  - 3 15A, 1P BAB Branch Breaker
  - 1 30A, 3P BAB-H Branch Breaker
  - 1 40A, 2P BAB Branch Breaker
  - 18 1P BAB Branch Provision Only
  - 1 30A, 2P BAB Branch Breaker
  - 2 20A, 2P BAB Branch Breaker
  - 16 20A, 1P BAB Branch Breaker
  - 1 SPD Factory Cable Connected to 30A Branch Breaker
  - 1 Surge Protective Device, 160 kA SPD Series - Standard w/ Surge Counter
  - 1 Copper Main Bus, 225 Amps
  - 1 Std. Bolted Cu Ground Bar (Cu Cable Only)
  - 1 Panel Nameplate - White with Black Letters - Screw on
  - 1 Circuit Directory - Metal Frame with Plastic Cover
  - 1 Type 1 Enclosure:EZB2060R
  - 1 EZ Trim, Door in Door, Concealed Hardware:EZT2060S
- Designations: EM-L1

~~1 Pow-R-Line2a~~

~~54 Circuits, 225A, Fully Rated, 480Y/277V 3Ph 4W, Copper Bus, 14k AIC,200A, 3P FD Main Breaker[Top Fed]  
Surface Mounted, Surge Protective Device, 160 kA SPD Series - Standard w/ Surge Counter~~

- ~~1 200A, 3P FD Main Breaker~~
  - ~~3 30A, 3P GHB Branch Breaker~~
  - ~~3 20A, 3P GHB Branch Breaker~~
  - ~~8 1P GHQ Branch Provision Only~~
  - ~~6 15A, 3P GHB Branch Breaker~~
  - ~~1 40A, 3P GHB Branch Breaker~~
  - ~~1 20A, 1P GHB Branch Breaker~~
  - ~~2 50A, 3P GHB Branch Breaker~~
  - ~~1 Surge Protective Device, 160 kA SPD Series - Standard w/ Surge Counter~~
  - ~~1 Copper Main Bus, 225 Amps~~
  - ~~1 Std. Bolted Cu Ground Bar (Cu Cable Only)~~
  - ~~1 Panel Nameplate - White with Black Letters~~
  - ~~1 Circuit Directory - Metal Frame with Plastic Cover~~
  - ~~1 Service Entrance Label~~
  - ~~1 Type 1 Enclosure:EZB2060R~~
  - ~~1 EZ Trim, Door in Door, Concealed Hardware:EZT2060S~~
- ~~Designations: HW-H1~~

**Main Breaker 150A  
EDB3150, Vert Mtd.**

SPD Std w/ Surge Counter  
60 kA SPD, Cable Connected

1	BAB3030H	BAB1020	2
3		BAB2020	4
5			6
7	BAB1020	BAB1020	8
9	BAB1020	BAB1015	10
11	BAB1020	BAB1015	12
13	BAB1020	BAB2040	14
15	BAB1020		16
17	BAB1020	BAB2020	18
19	BAB1020		20
21	BAB1020	BAB2030	22
23	BAB1020		24
25	BAB1020	BAB1015	26
27	BAB1020	PROV	28
29	BAB1020	BAB1020	30
31	BAB1020	PROV	32
33	PROV	PROV	34
35	PROV	PROV	36
37	PROV	PROV	38
39	PROV	PROV	40
41	PROV	PROV	42
43	PROV	PROV	44
45	PROV	PROV	46
47	PROV	PROV	48

Blank Cover  
8 inches

**General Information**

**(Section 1 of 1)**

**Service Voltage:** 208Y/120V 3Ph 4W **Enclosure:** Type 1  
**Bus Rating & Type:** 225A Copper **Neutral Rating:** 225A  
**Ground Bar:** Std. Bolted Copper, Cu cable only  
**S.C. Rating:** 10k A.I.C. Fully Rated

**Main Device Type:** Main Breaker - Top Cable Entry  
**Main Terminals:** Mechanical - (1) #14-4/0 (Cu/Al)  
**Neutral Terminals:** Mechanical - (1) #6-300 kcmil (Cu/Al)  
**Box Catalog No.:** EZB2060R  
**Trim:** EZ Trim, Door in Door, Concealed Hardware (EZT2060S)

Surface Mounted

**Box Dimensions:** 60." [1524.0mm]H x 20" [508.0mm]W x 5.75" [146.0mm]D  
**Min. Gutter Size:** Top = 5.5" [139.7mm] Bottom = 5.5" [139.7mm]  
 Left = 6.0" [152.4mm] Right = 6.0" [152.4mm]

**Panel ID Nameplate:** (1) EM-L1  
**Type:** Plastic, screw-on (2) 208Y/120V 3Ph 4W  
**Color:** White with Black Letters (3)

**UL** \*\*\*Non-Interchangeable Main Device\*\*\*

Copper Neutral  
 Trim Lock: Standard Lock & Key (Keyed WEM2)  
 Circuit Directory: Metal Frame with Plastic Cover  
 SPD Factory Cable Connected to 30A Branch Breaker  
 Main Circuit Breaker Trip Type: Thermal-Magnetic  
 Do not connect breakers with combined ampere ratings that exceed 140 amperes on any individual branch bus connector.

**Device Modifications:**

Ref # Description

**Branch Devices**

Qty	Poles	Trip	Frame	Amps	KAIC
16	1	20	BAB	100	10
1	3	30	BAB	100	10
3	1	15	BAB	100	10
2	2	20	BAB	100	10
1	2	30	BAB	100	10
1	2	40	BAB	100	10
18	1		PROV		

**Notes:**

The information on this document is created by Eaton Corporation. It is disclosed in confidence and it is only to be used for the purpose in which it is supplied.

PREPARED BY Fitzgerald, Michael F	DATE 01/21/12
APPROVED BY	DATE 01/21/12

**Eaton Corporation**

JOB NAME HDT RWRF  
 DESIGNATION EM-L1

VERSION  
7.8

TYPE  
PRL1a

DRAWING TYPE  
Customer Approval

NEG-ALT NUMBER  
DN851005V102-C000

REVISION  
A

DWG SIZE

G O  
SDN0301918

ITEM  
0091

SHEET  
1 OF 1

#### Panelboards and Lighting Controls

#### Contents

##### Description

##### Product Selection Guide

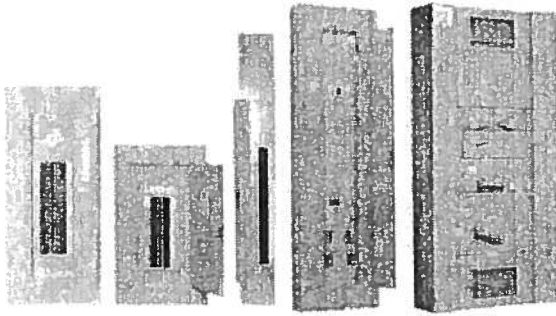

### Product Selection Guide

#### Product Types

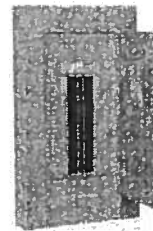
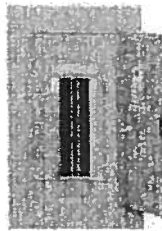

#### Type PRL1a

**Bolt-On or Plug-On Circuit Breakers 240 Vac Maximum**

Main lugs only  
400A maximum

Main Circuit breaker  
400A maximum

Branch circuit breakers  
100A maximum,  
Single-, two- and three-pole

#### Fusible Lighting Panelboard PRL1aF

**240 and 480Y/277 Vac Maximum**

Main lugs only  
400A maximum

Branch overcurrent protective devices  
30A maximum,  
Single-, two and three pole  
utilizing Class CC fuses

#### Type PRL1a-LX Column Type

**Bolt-On Circuit Breakers 240 Vac Maximum**

Main lugs only  
225A maximum

Main circuit breaker  
225A maximum

Branch circuit breakers  
100A maximum,  
Single-, two- and three-pole

#### Type PRL2a

**Bolt-On Circuit Breakers 240 or 480Y/277 Vac; 125/250 Vdc Maximum**

Main lugs only  
400A maximum

Main circuit breaker  
400A maximum

Branch circuit breakers  
100A maximum,  
Single-, two- and three-pole

#### Fusible Lighting Panelboard PRL2aF

**240 and 480Y/277 Vac Maximum**

Main lugs only  
400A maximum

Branch overcurrent protective devices  
30A maximum,  
Single-, two and three pole  
utilizing Class CC fuses

#### Type PRL2a-LX, Column Type

**Bolt-On Circuit Breakers 240 or 480Y/277 Vac; 125/250 Vdc Maximum**

Main lugs only  
225A maximum

Main circuit breaker  
225A maximum

Branch circuit breakers  
100A maximum,  
Single-, two- and three pole

## Pow-R-Line C Panelboards

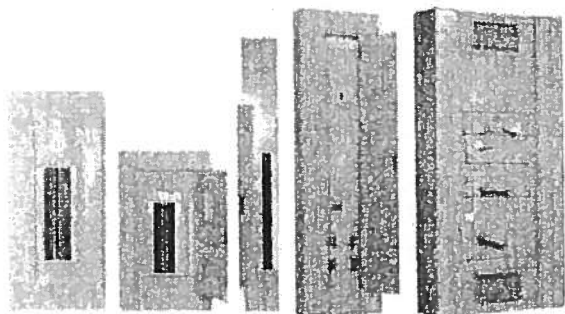

10

## Product Description

### Lighting and Distribution Panelboards

Eaton's assembled panelboards are designed for sequence phase connection of branch circuit devices. This allows complete flexibility of circuit arrangement (single-, two- or three-pole) to allow balance of the electrical load on each phase.

Sturdy, rigid chassis assembly ensures accurate alignment of interior with panel front; prevents flexing and minimizes possibility of loosening or damage to current carrying parts during and after installation.

Four-point in-and-out adjustment of panel interior is provided to meet critical depth dimensions on flush installations. This compensates for possible misalignment of box at installation.

Main lugs are mechanical solderless type and approved for copper or aluminum conductors

### Enclosures

Boxes are code-gauge galvanized steel, which include a painted box finished in ANSI-61 light gray to match the trim.

Standard panelboard cabinets are designed for indoor use. Alternate types are available for indoor and special purpose applications.

All enclosures are furnished in accordance with Underwriters Laboratories standards and include wiring gutters with proper wire bending space. Special cabinets can be provided at an additional charge.

The box dimensions shown are inside dimensions. For outside dimensions, add 1/4-inch (6.4 mm).

Standard panelboard boxes are supplied without knockouts (blank endwalls).

### Fronts

Fronts (trims) for all panelboards are made of code-gauge steel and have a high durability ANSI-61 light gray finish applied by a baked-on polyester powder coating paint system.

The fronts for lighting and appliance branch circuit panelboards and small power distribution panelboards include a door with rounded corners and concealed hinges. A flush-type latch and lock assembly is included. All locks are keyed alike. These trims are available in both surface- and flush-mounted designs.

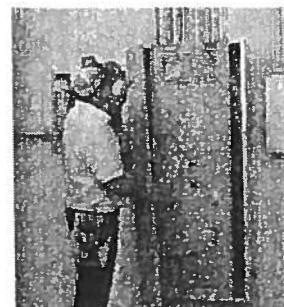

*The Three-Piece Trim for Larger Power Distribution Panelboards Provides for Easy Handling and Installation*

Fronts for power distribution panelboards utilize a unique breaker front cover design in which each device has a dedicated bolt-on steel cover. The individual covers form a single deadfront for the panelboard that is used in conjunction with two wiring gutter covers to complete the trim. A door is not finished as part of the standard offering on these panelboards but can be provided, for an additional charge, using a deeper than standard box.

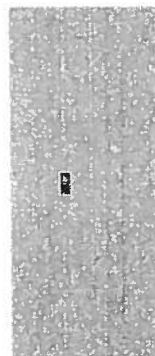

*EZ Trim Features Standard Door-in-Door with No Exposed Hardware or Sharp Edges (no Tools are Required for Installation)*

## Application Description

### Panelboard Selection Factors

In selecting a panelboard, the following factors must be considered:

- Service (voltage and frequency)
- Interrupting capacity (fully or series rated)
- Ampere rating of main
- Ampere ratings of branches
- Environment

### Panelboard Short-Circuit Rating

The short-circuit rating of Eaton's assembled panelboards are test verified by, and listed with, Underwriters Laboratories (UL). Generally, these ratings are that of the lowest interrupting rated device in the panel.

Certain exceptions to this rule exist where branch devices have been UL tested in combination with specific main devices having a higher interrupting rating. Where these defined main devices and branch breaker combinations are utilized, the series short-circuit rating of the assembled panelboard will be the same as the tested rating of the approved rated main device in series with the branches. Available main and branch breaker combinations are tabulated starting on **Page 366**. All combinations shown are UL tested and listed.

These series ratings apply to panels having main devices, or main lug only panelboards fed remotely by the device listed in the series ratings chart as the main, for which UL listed tests were conducted.

### Service Entrance Equipment

The National Electrical Code (NEC) requires that:

- A panel used as service entrance equipment must be located near the point where the supply conductors enter the building
- A panelboard having main lugs only shall have a maximum of six service disconnects to de-energize the entire panelboard from the supply conductors. Where more than six disconnects are required, a main service disconnect must be provided
- A disconnectable electrical bond must be provided between the neutral and ground
- A service entrance type UL label must be factory installed
- Ground fault protection of equipment shall be provided for each service disconnect rated 1000A or more if the electrical service is a solidly grounded wye system of more than 150V to ground, but not exceeding 600V phase-to-phase

**Note:** Service entrance panels must be identified as such on the order.

### Panelboard Standards

In 2008, both the National Electrical Code (Article 408) and UL 67 were updated to remove the mandated 42-circuit limitation. Eaton offers panelboards with more than 42 circuits for those jurisdictions that have adopted the 2008 NEC or later.

For jurisdictions that have not adopted the 2008 or later version of the National Electrical Code, the 42-circuit limitation for Lighting and Appliance Branch Panelboards remains in place. Check with your local code officials to determine specific jurisdiction status.

### Panelboard Installation

NEC requires that the operating handle of the topmost mounted device be no more than 6 feet 7 inches (2006.6 mm) above the finished floor and should be installed per NEC and manufacturer's instructions.

Additional boxes and fronts are required when the components required for one panelboard exceed the standard box dimensions.

### Multi-Section Panelboards

When two or more separate enclosures are required, separate fronts for each box are standard. A common front can be furnished at additional charge.

### Interconnecting Multi-Section Panelboards

When a panelboard, for connection to one feeder, must be furnished in more than one section (Box), each section must be furnished with main bus and terminals of the same rating, unless a main overcurrent device is provided in each section.

Sub-feed or through-feed provisions must also be included (and priced) to provide connection capability to the second section.

**Note:** Sub-feed or through-feed lugs cannot be used on any panelboard that is not protected by a single main overcurrent device either in the panelboard or immediately upstream, i.e., service entrance panelboards with main lugs only using the six disconnect rule.

**Sub-Feed Lugs**

Sub-feed lugs (see figure below) are one means of interconnecting multi-section panels. The sub-feed (second set of) lugs are mounted directly beside the main lugs. These are required in each section except the last panel in the lineup. The feeder cables are brought into the wiring gutter of the first section and connected to the main lugs. Another set of the same size cables are connected to the sub-feed lugs (Section 1) and are carried over to the main lugs of the adjacent panel. Cross connection cables are not furnished by Eaton. Sub-feed lugs are only available on main lug only panels.

**Note:** Sub-feed lugs may not be used on main lug only (six disconnect rule) service entrance panels.

**Sub-Feed Lugs**

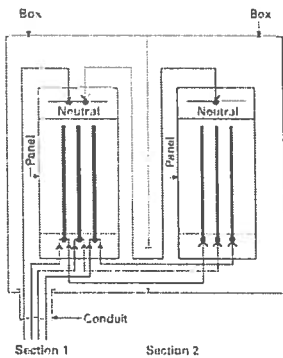

**Through-Feed Lugs**

Through-feed lugs (see figure below) are another method to interconnect multi-section panelboards. The incoming feeder cables are connected to the main lugs or main breaker at the bottom of panel (Section 1). Another set of lugs (through-feed) are located at the opposite end of the main bus. The interconnecting cables are connected to the through-feed lugs in Section 1 and are carried over to the main lugs in Section 2. The connection arrangement could be reversed, i.e., main lugs at top; through-feed lugs at bottom end of panel. Cross cables are not furnished by Eaton.

**Note:** Through-feed lugs may not be used on main lug only (six disconnect rule) service entrance panels.

**Through-Feed Lugs**

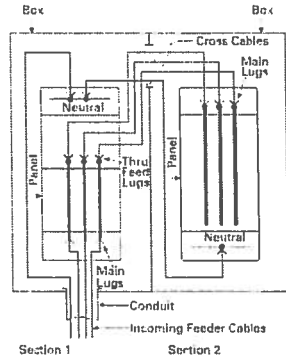

**Multiple Section Panelboard—Flush Mounted**

Shown below is the standard method for flush mounting multiple section lighting and distribution panelboards using standard flush trims.

**Multiple Section Panelboard Flush Mounted—Dimensions in Inches (mm)**

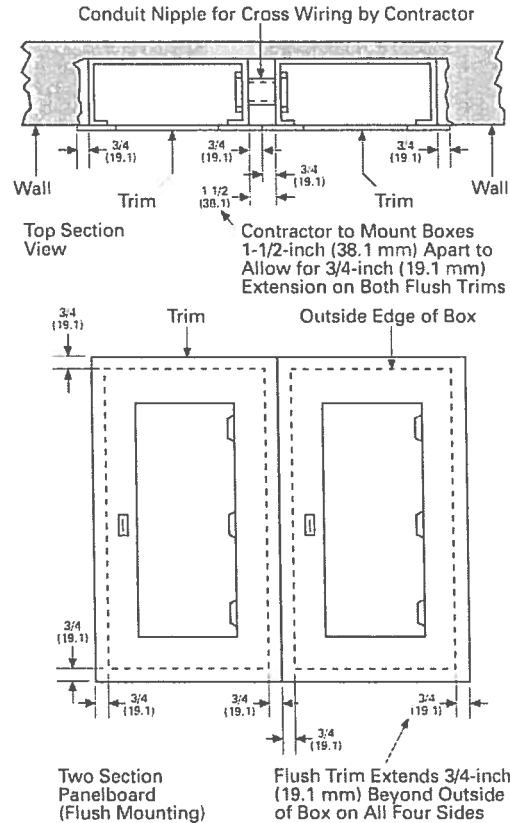

**Overcurrent Protection**

The following requirements will be found in the NEC:

Each lighting and appliance branch circuit panelboard shall be individually protected on the supply side by not more than two main circuit breakers or two sets of fuses having a combined rating not greater than that on the panelboard.



## Pow-R-Line C Panelboards

**Branch Circuit Loading for Lighting Panels**

The size of mains and branches should be selected based on the following.

- Motor circuits: NEC Article 430
- Diversity factor
- Provision for future loading

**Exception Number 1:**

Individual protection for a lighting panelboard is not required when the panelboard feeder has overcurrent protection not greater than that of the panelboard.

**Exception Number 2:**

For existing installations, individual protection for lighting panelboards is not required where such panelboards are used as service equipment in supplying an individual residential occupancy and where any bus supplying 15 or 20A circuits is protected on the supply side by an overcurrent device.

**Ambient Temperatures**

The primary function of an overcurrent device is to protect the conductor and its insulation against overheating. In selecting the size of the devices and conductors, consideration should be given to the ambient temperature surrounding the conductors within and external to the panelboard. Cumulative heating within the panelboard may cause premature operation of the overcurrent protective devices.

Underwriters Laboratories test procedures are based, in part, on 80% loading of panelboard branch circuit devices. The NEC limits the loading of overcurrent devices in panelboards to 80% of rating where in normal operation the load will continue for three hours or more. Further derating may be required, depending on such factors as ambient temperature, duty cycle, frequency or altitude.

**Exception:** There is one exception to this rule in both UL and NEC. It applies to assemblies and overcurrent devices that have been listed for continuous duty at 100% of its rating.

**Special Conditions**

Standard panelboards, assembled with standard components, are adequate for most applications. However, special consideration should be given to those required for application under special conditions such as:

- Excessive vibration or shock
- Frequencies above 60 cycles
- Altitudes above 6600 feet (2011.7m)
- Damp environment (possible fungus growth)
- Compliance with federal, state and municipal electrical codes and standards

**Seismic Considerations**

The Uniform Building Code® and the International Building Code, as well as local and state building codes, place an emphasis on seismic building design requirements. Electrical distribution systems are treated as attachments to the building and therefore, fall into this category.

All Eaton panelboards are seismic qualified at the highest possible level, and have been tested in accordance with ANSI C37.81. This standard quantifies actual earthquake conditions, as well as equipment seismic capability.

**Harmonic Currents**

Standard panelboard neutrals are rated for 100% of the panelboard current. However, since harmonic currents can cause overheated neutrals, an option is provided for neutrals to be rated at 200% (1200A maximum neutral for 600A main bus) of the panelboard phase current.

Panelboards with the 200% rated neutral are UL listed as suitable for use with non-linear loads.

Prior to specifying the 200% rated neutral, Eaton recommends a harmonic survey be conducted of the distribution system, be it new or existing.

**Surge Protective Devices**

The quality of power feeding sensitive electronic loads is critical to the reliable operation of any facility. In modern offices, hospitals, and manufacturing facilities, the most frequent causes of microprocessor-based equipment downtime and damage are voltage transients and electrical noise.

Electrical loads and microprocessor-based equipment are highly susceptible to both high and low energy transients. High energy transients include lightning induced surges and power company switching. These high energy transients can destroy components instantly.

More frequently the electrical system experiences low energy transients and high frequency noise.

The effects of continual low energy transients and high frequency noise can cause erratic equipment performance or sudden failure of electronic circuit board components.

Eaton can provide protective and diagnostic systems integral to panelboards.

The surge protective device (SPD) is integrated into the panelboards using a "zero lead length" direct bus bar connection.



*Pow-R-Line 4*

The SPD protects sensitive electronic equipment from the damaging effects of high and low energy transients, as well as high frequency noise.

**Standards and Certifications**

Eaton's panelboards are designed to meet the following applicable industry standards, except where noted:

- Underwriters Laboratories:
  - Panelboards: UL 67
  - Cabinets and Boxes: UL 50

**Note:** Only panelboards containing UL listed devices can be UL labeled.

- National Electrical Code
- NEMA Standards: PB 1
- Federal Specification W-P-115c:
  - Circuit Breakers—Type I Class I
  - Fusible Switch—Type II Class I



## Technical Data and Specifications

## Panelboard Selection Guide

Panelboard Type	Device Type	Maximum Voltage Rating		Maximum Main Rating (Amperes)			Branch Circuits Ampere Range	Sub-Feed Breaker Maximum Amperes	AC Interrupting Capacity rms Symmetrical Amperes (kA)	
		AC	DC	MLO	Main Device	Fully Rated			Series Rated	
PRL1a	Breaker	240	—	400	400	15-100	400	10-22	22-100	
PRL1R	Breaker	240	—	225	225	15-100	—	10-22	22-100	
PRL1aF	Fusible	240	—	400	400	15-30	400	200	—	
PRL1a-LX	Breaker	240	—	225	225	15-100	—	10-22	22-100	
PRL2a	Breaker	240	250	400	400	15-100	400	65	65-200	
	Breaker	480Y/277	250	400	400	15-100	400	14	22-150	
PRL2R	Breaker	240	—	225	225	15-100	—	10-22	22-200	
	Breaker	480Y/277	—	225	225	15-100	—	14	22-100	
PRL2aF	Fusible	480Y/277	—	400	400	15-30	400	200	—	
PRL2a LX	Breaker	240	250	225	225	15-100	—	65	65-200	
	Breaker	480Y/277	250	225	225	15-100	—	14	22-150	
PRL3a	Breaker	240	250	800	600	15-225	600	10-200	22-200	
	Breaker	480	250	800	600	15-225	600	14-100	22-150	
	Breaker	600	250	800	600	15-225	600	14-35	—	
PRL3E	Breaker	240	250	600	600	15-125	400	25-100	100-200	
	Breaker	480Y/277	250	600	600	15-125	400	18-65	65-100	
	Breaker	480	250	600	600	15-125	400	18-65	65-100	
PRL4B	Breaker	240	600	1200	1200	15-1200	—	10-200	22-200	
	Breaker	480	600	1200	1200	15-1200	—	14-200	22-150	
	Breaker	600	600	1200	1200	15-1200	—	14-200	—	
PRL4F	Fusible	240	250	1200	1200	30-1200	—	100-200	—	
	Fusible	600	250	1200	1200	30-1200	—	100-200	—	
PRL5P	Breaker	240	250	1200	1200	15-1200	—	10-200	22-200	
	Breaker	480	250	1200	1200	15-1200	—	14-200	22-150	
	Breaker	600	250	1200	1200	15-1200	—	14-200	—	
PRC100/50 PRC25	Breaker	240	—	400	400	15-225	—	10-65	22-100	
	Breaker	480Y/277	—	400	400	15-225	—	14	65-100	
Elevator Control	Fusible	240	—	800	600	15-200	—	200	—	
	Fusible	480Y/277	—	800	800	15-200	—	200	—	
	Fusible	480	—	800	800	15-200	—	200	—	

10

### Pow-R-Line C Panelboards

#### Terminal Wire Ranges, Pressure-Type Al/Cu Terminals Except as Noted

**Note:** All terminal sizes are based on wire ampacities corresponding to those shown in NEC Table 310-16 under the 75°C insulation columns (75°C wire). The use of smaller size, (in circular mils), regardless of insulation temperature rating, is not permitted.

Where copper-aluminum terminals are supplied on designated panelboard types, best results are obtained if a suitable joint compound is applied when aluminum conductors are used.

Check Eaton's standard terminal sizes versus customer requirements. In particular, 400 and 800A breakers often require nonstandard lugs.

Optional 750 kcmil mechanical screw-type terminals are available upon request. Panelboard dimensions may be affected, refer to Eaton.

#### Standard Main Lug Terminals

Panel Type	Wire Size Ranges for Ampere Capacity						
	100A	225A	250A	400A	600A	800A	1200A
PRL1a	#12-1/0	#6-300 kcmil	—	(2) #4-500 kcmil	—	—	—
PRL2a	#12-1/0	#6-300 kcmil	—	(2) #4-500 kcmil	—	—	—
PRL1R	#12-1/0	#6-300 kcmil	—	(2) #4-500 kcmil	—	—	—
PRL2R	#12-1/0	#6-300 kcmil	—	(2) #4-500 kcmil	—	—	—
PRL1aF	#12-1/0	#6-300 kcmil	—	(2) #4-500 kcmil	—	—	—
PRL2aF	#12-1/0	#6-300 kcmil	—	(2) #4-500 kcmil	—	—	—
PRL3a	#12-1/0	—	#6-350 kcmil	(2) #4-500 kcmil	(2) #4-500 kcmil	(3) #4-500 kcmil	—
PRL3E	#12-1/0	—	#6-350 kcmil	(2) #4-500 kcmil	(2) #4-500 kcmil	—	—
PRL4	—	—	#4-500 kcmil	(2) #4-500 kcmil	(2) #4-500 kcmil	(3) #4-500 kcmil	(4) #4-500 kcmil
PRL1a-LX	#12-1/0	#6-300 kcmil	—	—	—	—	—
PRL2a-LX	#12-1/0	#6-300 kcmil	—	—	—	—	—
PRC100/PRC50	#12-1/0	—	#6-350 kcmil	(2) #4-500 kcmil	—	—	—
PRC25	#12-1/0	#6-300 kcmil	—	(2) #4-500 kcmil	—	—	—
PRL5P	—	—	—	(1) #1/0-500 kcmil or (2) #1/0-250 kcmil	(2) #4-500 kcmil	(2) #2-500 kcmil or (3) #2-400 kcmil	(4) #4-750 kcmil
Elevator Control	—	—	#4-500 kcmil	(2) #4/0-500 kcmil	(2) #4/0-500 kcmil	(3) #4/0-500 kcmil	—

Standard Circuit Breaker Terminals

Breaker Type	Ampere Rating	Wire Range
BAB, OSHW, BABRSP, HQP, OPHW	15-70 90-100	#14-#1 #8-1/0
EDB, EDS, ED, EDH, EDC	100-225	#4-4/0 or #6-300 kcmil
EGB, EGE, EGS, EGH	15-50 60-125	#14-3/0 AL/CU #6-3/0 AL/CU
EHD, FDB, FD, HFD, FDC, HFD0C 1	15-100 125-225	#14-1/0 #4-4/0
FCL	15-100	#14-1/0
GHB, HGHB, GHQ, GHCRSP	15-20 25-100	#14-#10 #10-1/0
EGB, EGS, EGH	15-50 60-125	#14-1/0 #6-2/0
JD, HJD, JDC, HJDDC 2	70-250	#4-350 kcmil
DK	250-350 400	250-500 kcmil (2) 3/0-250 kcmil or (1) 3/0-500 kcmil
KD, HKD, KDC, HKDDC, 2 CKD, CHKD	225 350 400	(1) #3-350 kcmil (2) 3/0-250 kcmil or (2) 3/0-250 kcmil or (1) 3/0-500 kcmil
LHH	150-400 150-400 150-400	#2-500 kcmil (2) #2-500 kcmil (1) 500-750 kcmil
LGE, LGH, LGC, LGV, LHH 3	250-400 500-600	(1) #2-500 kcmil (2) #2-500 kcmil
LD, HLD, LDC, HLD0C 7 CLD, CHLD	300-500 600	(2) 250-350 kcmil (2) 400-500 kcmil
MDL, HMDL, HMDLDC 2 CMDL, CHMDL	400-600 700-800	(2) #1-500 kcmil (3) 3/0-400 kcmil
ND, HND, CND, CHND, NDC, CNDC	800-1000 1200	(3) 3/0-400 kcmil (4) 4/0-500 kcmil
LCL	125-225 250-400	(1) #6-350 kcmil (1) #4-250 kcmil and (1) 3/0-600 kcmil
FB-P	15-100	#14-1/0
LA-P	70-225 250-400	#6-350 kcmil (1) #4-250 kcmil and (1) 3/0-600 kcmil
NB-P, NBDC 3	300-700 800	(2) #1-500 kcmil (3) 3/0-400 kcmil

FDPW Switch Terminals

Ampere Rating	Wire Range
30	#14-1/0
60	#14-1/0
100	#14-1/0
200	#4-300 kcmil
400	250-750 kcmil or (2) 3/0-250 kcmil
600	(2) #4-600 kcmil or (4) 3/0-250 kcmil
800	(3) 250-750 kcmil or (6) 3/0-250 kcmil
1200	(4) 250-750 kcmil or (8) 3/0-250 kcmil

Elevator Control Panel Feeder Terminals

Ampere Rating	Wire Range
30	#14-1/0
60	#14-1/0
100	#14-1/0
200	#4-300 kcmil

Notes

- 1 LHH is 400A maximum.
- 2 Suitable for DC applications only





**TAB 3 Dry Type Transformers**

# EATON

## Technical Data

01/21/12

Job Name: HDT RWRF  
SDN0301918

14:45:12

**Customer Bill of Material**

1 Dry Type Transformer

Standard Transformer Catalog Number: V48M28B45CUEE  
Transformer Type: General Purpose Vented  
3 PHASE, 45 KVA, 480 Primary Volts, 208Y/120 Secondary Volts,  
80C Temperature Rise, Copper Winding Material, NEMA 2 (N3R w/opt'l weathershield) Enclosure Type, 60 HZ,  
Frame 912B, Wiring Diagram 280B

Standard Values

K-Factor: 1  
TAPS: 2@+2.5%, 4@-2.5%  
NEMA ST20 Sound Level: 45  
Nema TP-1 Energy Efficient: Y  
Infrared Viewing Window: None

Field-Installed Accessories

Lug Kit: LKS1

Designations: EM-TX1

~~1 Dry Type Transformer~~

~~Standard Transformer Catalog Number: V48M28B30CUEE  
Transformer Type: General Purpose Vented  
3 PHASE, 30 KVA, 480 Primary Volts, 208Y/120 Secondary Volts,  
80C Temperature Rise, Copper Winding Material, NEMA 2 (N3R w/opt'l weathershield) Enclosure Type, 60 HZ,  
Frame 912B, Wiring Diagram 280B~~

~~Standard Values~~

~~K-Factor: 1  
TAPS: 2@+2.5%, 4@-2.5%  
NEMA ST20 Sound Level: 45  
Nema TP-1 Energy Efficient: Y  
Infrared Viewing Window: None~~

~~Field-Installed Accessories~~

~~Lug Kit: LKS1~~

~~Designations: T20~~

**All orders must be released for manufacture within 90 days of date of order entry. If approval drawings are required, drawings must be returned approved for release within 60 days of mailing. If drawings are not returned accordingly, and/or if shipment is delayed for any reason, the price of the order will increase by 1.0% per month or fraction thereof for the time the shipment is delayed.**



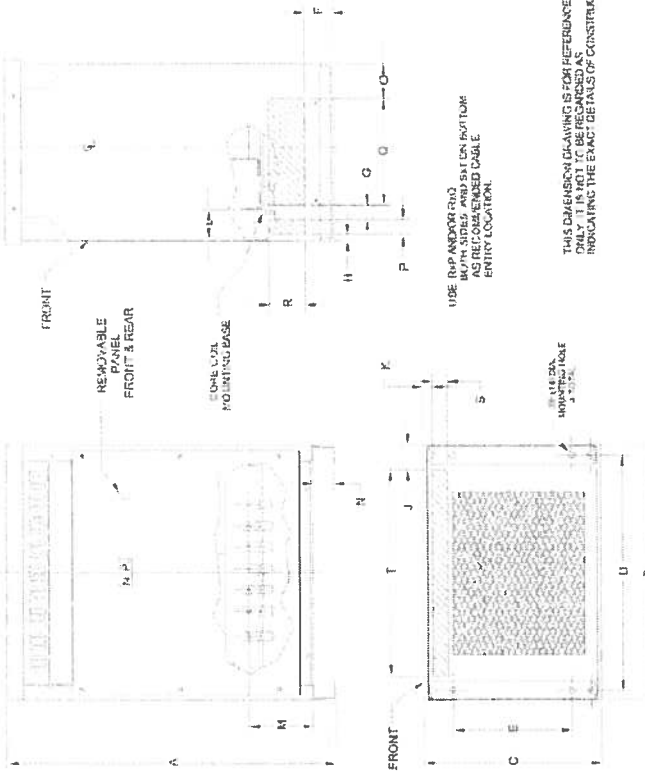

DIMENSIONS IN INCHES (MM)

FRAME	A	B	C	D	E	F	G	H	J	K
FRS125	30.00(762)	22.00(559)	10.50(267)	21.00(533)	11.00(279)	2.50(63)	1.25(32)	5.0(127)	2.75(70)	4.62(117)
	3.00(76)	3.95(100)	2.84(72)	3.12(79)	1.40(36)	0.51(12.7)	0.75(19)	1.40(36)	1.50(38)	1.50(38)

Rev-A-Elect'13

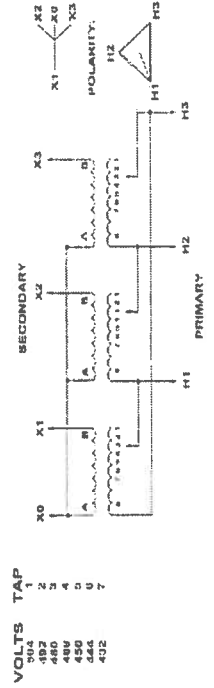

**V48M28B45CUJEE**  
 Style Number:  
 KVA Rating: 45  
 K-Factor: 1  
 NEMA TP-1: Y

Primary Voltage: 480  
 Secondary Voltage: 208Y/120  
 Taps: 2@+2.5%, 4@-2.5%  
 Temperature Rise: 80C  
 Winding Material: Copper  
 Frequency (Hz): 60  
 Sound Level (dB): 45

Average Impedance %: 3.94  
 Weight (lbs): 504

Infrared Viewing Window: Not Included  
 Accessories Included: Lug Kit

The information on this document is created by Eaton Corporation. It is disclosed in confidence and it is only to be used for the purpose in which it is supplied.	PREPARED BY Fitzgerald, Michael F	DATE 01/21/12	<b>Eaton Corporation</b> Pittsburgh, PA
	APPROVED BY	DESIGNATION HDT RWR/F EM-TX1	DRAWING TYPE Customer Appr.
NEG-ALT NUMBER DN851005V102-C000	REVISION A	VERSION 7.8	DRAWING TYPE Customer Appr.
	DWG SIZE A	G.O. SDN0301918	SHEET 1 OF 1

### NEMA TP-1 Energy-Efficient Transformers

Type DT-3



#### Product Description

**Note:** The following pages provide listings for most standard transformer ratings and styles. For other ratings or styles not shown, or for special enclosure types (including stainless steel), refer to Eaton.

#### Types DS-3, DT-3

- Ventilated, NEMA 2 enclosure standard
- Suitable for indoor applications, outdoors when weathershields are also installed
- Upright mounting only
- 220°C insulation system
- 150°C rise standard; 115°C or 80°C rise optional
- Available in single-phase ratings 15–167 kVA, 600 volts primary (DS-3)
- Available in three-phase ratings 15–1500 kVA and up to 600 volts primary (DT-3)

#### Application Description

##### NEMA TP-1-2002

compliant energy-efficient transformers are specifically designed to meet the energy efficiency standards set forth in NEMA Standards publication, TP-1-2002, "Guide for Determining Energy Efficiency for Distribution Transformers." Surveys have shown that the average loading of low voltage dry-type distribution transformers, over a 24-hour period, is approximately 35%. NEMA TP-1 compliant transformers are optimized to offer maximum efficiency at 35% of nameplate rating.

The range of products covered by NEMA TP-1-2002 are:

##### NEMA TP-1-2002 Product Range

Rating	Voltage Class	Voltage
	Primary voltage	34.5 kV and below
	Secondary voltage	600V and below
<b>Dry-Type Rating</b>	Single-phase	10–833 kVA
	Three-phase	15–2500 kVA
<b>Liquid Rating</b>	Single-phase	10–833 kVA
	Three-phase	15–2500 kVA

Transformers that are currently specifically excluded from the scope of NEMA Standard TP-1-2002 include:

- Liquid-filled transformers below 10 kVA
- Dry-type transformers below 15 kVA
- AC and DC drives transformers
- Rectifier transformers designed for high harmonics
- Autotransformers
- Non-distribution transformers, such as UPS transformers
- Special impedance or regulation transformers
- Regulating transformers
- Sealed and non-ventilated transformers
- Machine tool transformers
- Welding transformers
- Transformers with tap ranges greater than 15%
- Transformers with a frequency other than 60 Hz
- Grounding transformers
- Testing transformers

Efficiency levels set forth in NEMA TP-1-2002.

#### NEMA TP-1-2002 Efficiency Levels

##### Tables of Energy Efficiency NEMA Class 1 Efficiency Levels Dry-Type Distribution Transformers—Low Voltage (600V and below)

Single-Phase		Three-Phase	
kVA	Efficiency	kVA	Efficiency
15	97.7	15	97.0
25	98.0	30	97.5
37.5	98.2	45	97.7
50	98.3	75	98.0
75	98.5	112.5	98.2
100	98.6	150	98.3
167	98.7	225	98.5
250	98.8	300	98.6
333	98.9	500	98.7
—	—	750	98.8
—	—	1000	98.9

**Features, Benefits and Functions**

- 60 Hz operation (except as noted)
- Short-term overload capability as required by ANSI
- Meet NEMA ST-20 sound levels
- Meet federal energy efficiency requirements for low voltage dry-type distribution transformers effective as of January 1, 2007

**Standards and Certifications**

- UL listed

**Industry Standards**

All Eaton dry-type distribution and control transformers are built and tested in accordance with applicable NEMA, ANSI and IEEE Standards. All 600 volt class transformers are UL listed unless otherwise noted.

**Seismically Qualified**

Eaton manufactured dry-type distribution transformers are seismically qualified and exceed requirements of the Uniform Building Code (UBC), International Building Code (IBC) and California Code Title 24.

## Accessories

Please refer to Section 9.7 **Page 319**.

## Technical Data and Specifications

### Frequency

Eaton standard dry-type distribution transformers are designed for 60 Hz operation. Transformers required for other frequencies are available and must be specifically designed.

### Overload Capability

Short-term overload is designed into transformers as required by ANSI. Dry-type distribution transformers will deliver 200% nameplate load for one-half hour, 150% load for one hour and 125% load for four hours without being damaged, provided that a constant 50% load precedes and follows the overload. See ANSI C57.96-01.250 for additional limitations.

Continuous overload capacity is not deliberately designed into a transformer because the design objective is to be within the allowed winding temperature rise with nameplate loading.

### Insulation System and Temperature Rise

Industry standards classify insulation systems and rise as shown below:

#### Insulation System Classification

Ambient	+ Winding Rise	+ Hot Spot	= Temp. Class
40°C	55°C	10°C	105°C
40°C	80°C	30°C	150°C
25°C	135°C	20°C	180°C
40°C	115°C	30°C	185°C
40°C	150°C	50°C	220°C

The design life of transformers having different insulation systems is the same—the lower-temperature systems are designed for the same life as the higher-temperature systems.

### Enclosures

Eaton's ventilated transformers, Types DS-3 and DT-3, use a NEMA 2 rated (drip-proof) enclosure as standard, and are rated NEMA 3R with the addition of weathershields.

### Winding Terminations

Primary and secondary windings are terminated in the wiring compartment. Encapsulated units have copper leads or stabs brought out for connections. Ventilating transformers have leads brought out to terminals that are pre-drilled to accept Cu/Al lugs. Aluminum-wound transformers have aluminum terminals; copper-wound models have copper terminals. **Lugs are not supplied with these transformers.** Eaton recommends external cables be rated 90°C (sized at 75°C ampacity) for encapsulated designs and 75°C for ventilated designs.

### Series-Multiple Windings

Series-multiple windings consist of two similar coils in each winding that can be connected in series or parallel (multiple). Transformers with series-multiple windings are designated with an "x" or "/" between the voltage ratings, such as voltages of "120/240" or "240 x 480." If the series-multiple winding is designated by an "x," the winding can be connected only for a series or parallel. With the "/" designation, a mid-point also becomes available in addition to the series or parallel connection. As an example, a 120 x 240 winding can be connected for either 120 (parallel) or 240 (series), but a 120/240 winding can be connected for 120 (parallel), or 240 (series), or 240 with a 120 mid-point.

For additional information, please refer to Section 9.7 **Page 319**.

### Sound Levels

All Eaton 600 volt class general-purpose dry-type distribution transformers are designed to meet NEMA ST-20 sound levels listed here. These are the sound levels measured in a soundproof environment. Actual sound levels measured at an installation

will likely be higher (as much as 15 dB greater) due to electrical connections and environmental conditions. Lower sound levels are available and should be specified when the transformer is going to be installed in an area where sound may be a concern.

### Average Sound Levels <sup>Ⓢ</sup>

#### NEMA ST-20 Average Sound Level in dB

kVA	Up to 1.2 kV		Above 1.2 kV
	Ventilated	Encapsulated	Ventilated
0-9	40	45	45
10-50	45	50	50
51-150	50	55	55
151-300	55	57	58
301-500	60	59	60
501-700	62	61	62
701-1000	64	63	64
1001-1500	65	64	65

#### Notes

<sup>Ⓢ</sup> Currently being reviewed and revised by NEMA

For other ratings or styles not shown, or for special enclosure types (including stainless steel), refer to Eaton.

Catalog Number Selection

General-Purpose, Energy-Efficient, Mini-Power Center, Shielded Isolation, Nonlinear, Buck-Boost, Marine Duty Transformers—Example: S20N11S05A

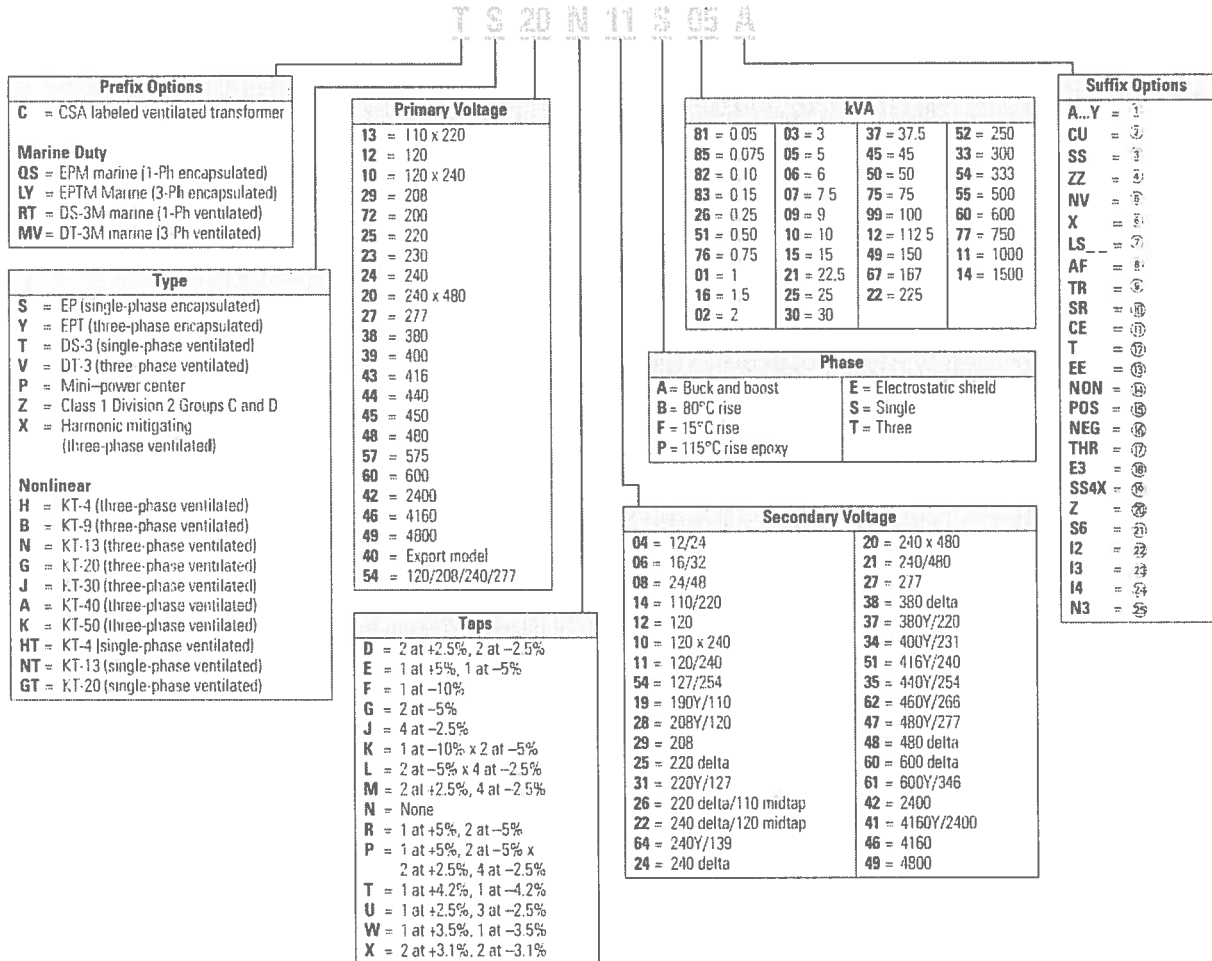

Notes

- ① Model number is not used on newly designed/re-designed transformers
- ② Copper windings
- ③ Grade 304 stainless steel enclosure (does not imply a NEMA 4X rating)
- ④ Open type core and coil assembly
- ⑤ Totally enclosed non-ventilated DS-3 or DT-3
- ⑥ 50/60 Hz
- ⑦ Low sound design. LS47 indicates low sound equal to 47 dB, LS42 indicates 42 dB

- ⑧ Fungus proof.
- ⑨ Certified test report of standard production tests for the specific serial number to be shipped.
- ⑩ Certified sound level report
- ⑪ CE Marked.
- ⑫ Thermal indicator embedded in center coil. Suffix "TT" indicates two thermal indicators of different temperature ratings, are installed
- ⑬ NEMA TP-1 efficient.

- ⑭ 0° phase-shift (used with HMTs).
- ⑮ +15° phase-shift (used with HMTs).
- ⑯ -15° phase-shift (used with HMTs).
- ⑰ -30° phase-shift (used with HMTs).
- ⑱ CSL3 DOE 2007 energy-efficient.
- ⑲ NEMA 4X Grade 304 stainless steel enclosure.
- ㉑ Easy install base.
- ㉒ Grade 316 stainless steel enclosure (does not imply NEMA 4X rating)
- ㉓ Integral 2-inch infrared viewing window
- ㉔ Integral 3-inch infrared viewing window
- ㉕ Integral 4-inch infrared viewing window
- ㉖ NEMA premium efficiency.

For Eaton's industrial control transformers catalog number selection, see **Page 316**. Contact your local Eaton sales office for voltage combinations not shown. Use table for catalog number breakdown only. Do not use to create catalog numbers because all combinations may not be valid.

## Transformer Standards, Technical Data and Accessories

## Terminal Lug Kits for Type DT-3 Transformers

Typical Sizing	Terminal Lugs Cable Range	Quantity	Hardware Bolt Size	Quantity	Catalog Number
15–37.5 kVA single-phase	#14–#2	8	1/4-20 x 3/4	8	LKS1
15–45 kVA three-phase	#6–250 kcmil	4			
50–75 kVA single-phase	#6–250 kcmil	12	1/4-20 x 3/4	8	LKS2
75–112.5 kVA three-phase			1/4-20 x 1-3/4	8	
100–167 kVA single-phase	#6–250 kcmil	3	1/4-20 x 3/4	3	LKS3
150–300 kVA three-phase	#2–600 kcmil	22	3/8-16 x 2	16	
500 kVA three-phase	#2–600 kcmil	29	3/8-16 x 2	18	LKS4

## Rodent Screens

Description	Frame Size(s) <sup>①</sup>	Catalog Number
Rodent screens are used to discourage entry by birds or rodents	908, 909	RS01
	910A, 911, 912	RS02
	913B, 914B, 915B	RS03
	916	RS04
	917, 918, 918A	RS05
	919, 920, 919E, 919EX, 920E, 920EX	RS06
	916A, 916B	RS07
	922	RS08
	923	RS09
	814, 821, 814E	RS11
	815	RS12
	816	RS13
	817, 818	RS14
	819, 820	RS15
	912B, 912Z	RS16
	914D, 915D, 914Z, 915Z	RS17
	916Z	RS07

## Replacement Parts for Mini-Power Centers

Frame	Deadfront Cover (Breaker Cover)	Front Cover
283	47-37503	7074C98H04
284	47-37503-2	7074C98H01
285	47-37503-3	7074C98H02
286	47-37503-4	7074C98H02
287	47-37503-5	7074C98H03
289	47-37459	7074C44H01
290	47-37459-2	7074C44H02
291	47-37459-3	7074C44H03
289A	47-42072-1	7074C44H01
290A	47-42072-2	7074C44H02
291A	47-42072-3	7074C44H03

**Notes**

<sup>①</sup> Effective June 1, 2001, frame numbers will have a prefix of FR, e.g., **FR819**. Dimensions, accessories and so on are still applicable as if the FR did not exist.

Lugs are rated Al/Cu and are suitable for use with either aluminum or copper conductors.