

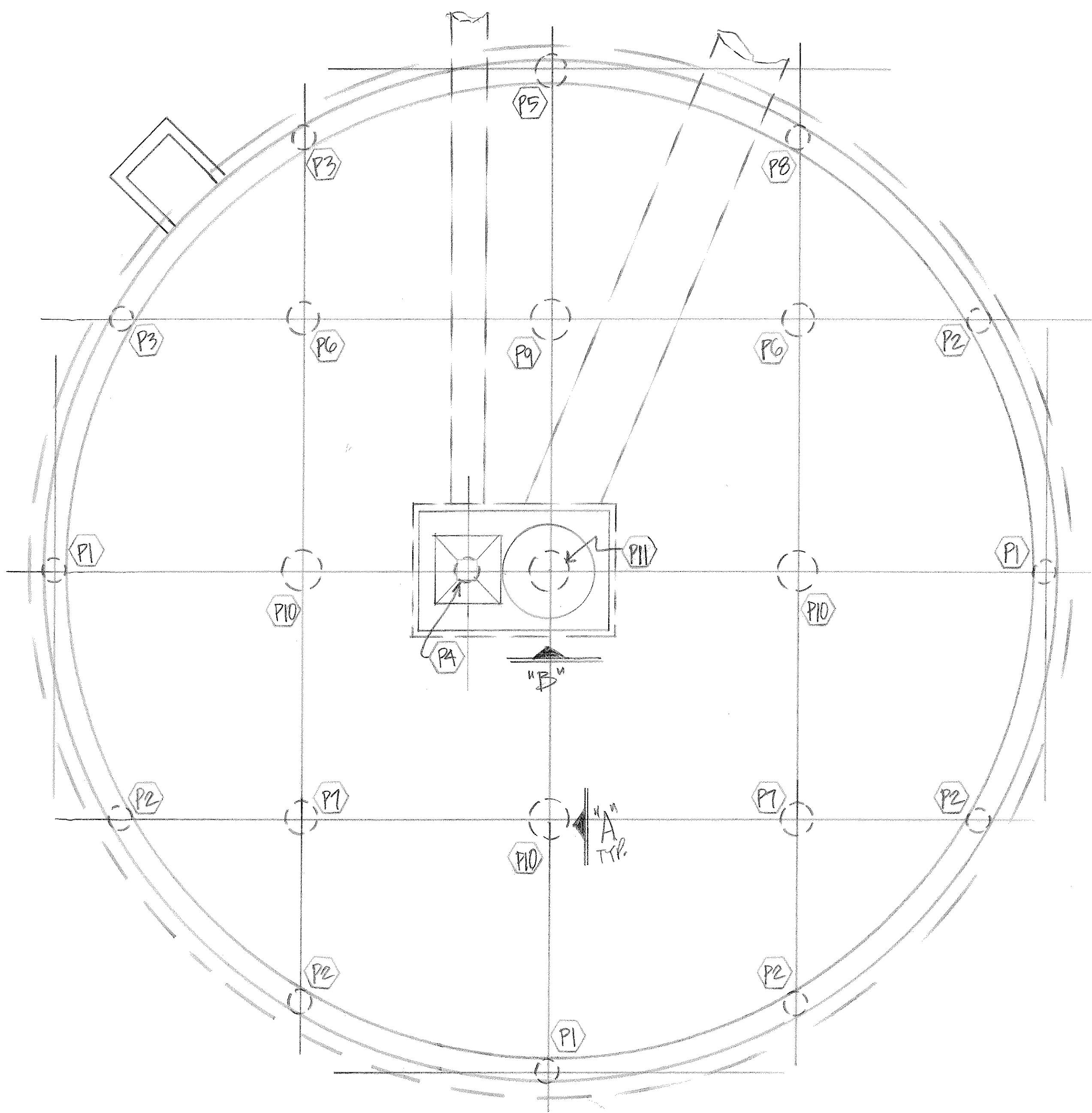

QTY	SIZE	TYPE	LENGTH FT. - IN.	MARK	SKETCH	A	B	C	D	E	F/R	G	H	K	J	O
3	T3		318	○				6-4				1-7				2-0
3	T3		324	○				3-2				1-7				1-0
3	T3		325	○				4-9				1-7				1-6
7	T7		726	□			1-2	6-6								

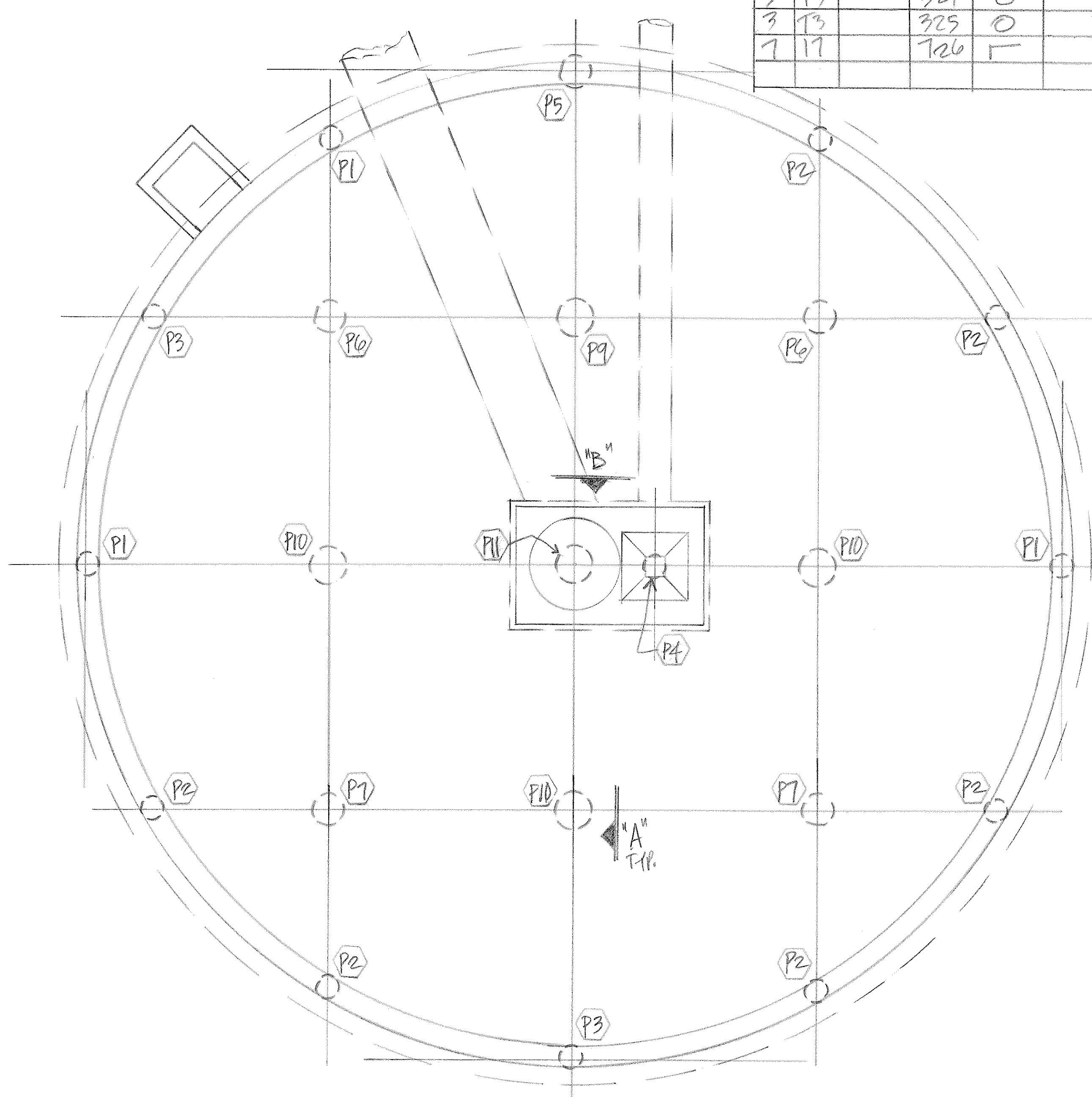

PIER PLAN & SECONDARY CLARIFIER #1



PIER PLAN & SECONDARY CLARIFIER #2

MK.	QTY.	VERT.	TIES @12"Ø	DWLS. (PROJ.)
P1	6	6#6x36-3	37(324)	4(726) 1-4 PROJ.
P2	11	6#6x33-3	34(324)	4(726) do.
P3	4	6#6x34-3	35(324)	4(726) do.
P4	2	6#6x25-8	27(324)	4(726) 1-0 PROJ.
P5	2	6#7x31-3	32(325)	4(726) 1-4 PROJ.
P6	4	6#7x36-5	38(325)	4(726) do.
P7	4	6#7x35-5	37(325)	4(726) do.
P8	ONE	6#6x35-3	36(324)	4(726) do.
P9	2	6#9x33-10	35(3118)	4(726) do.
P10	6	6#9x31-10	33(3118)	4(726) do.
P11	2	6#9x31-8	33(3118)	4(726) 1-0 PROJ.

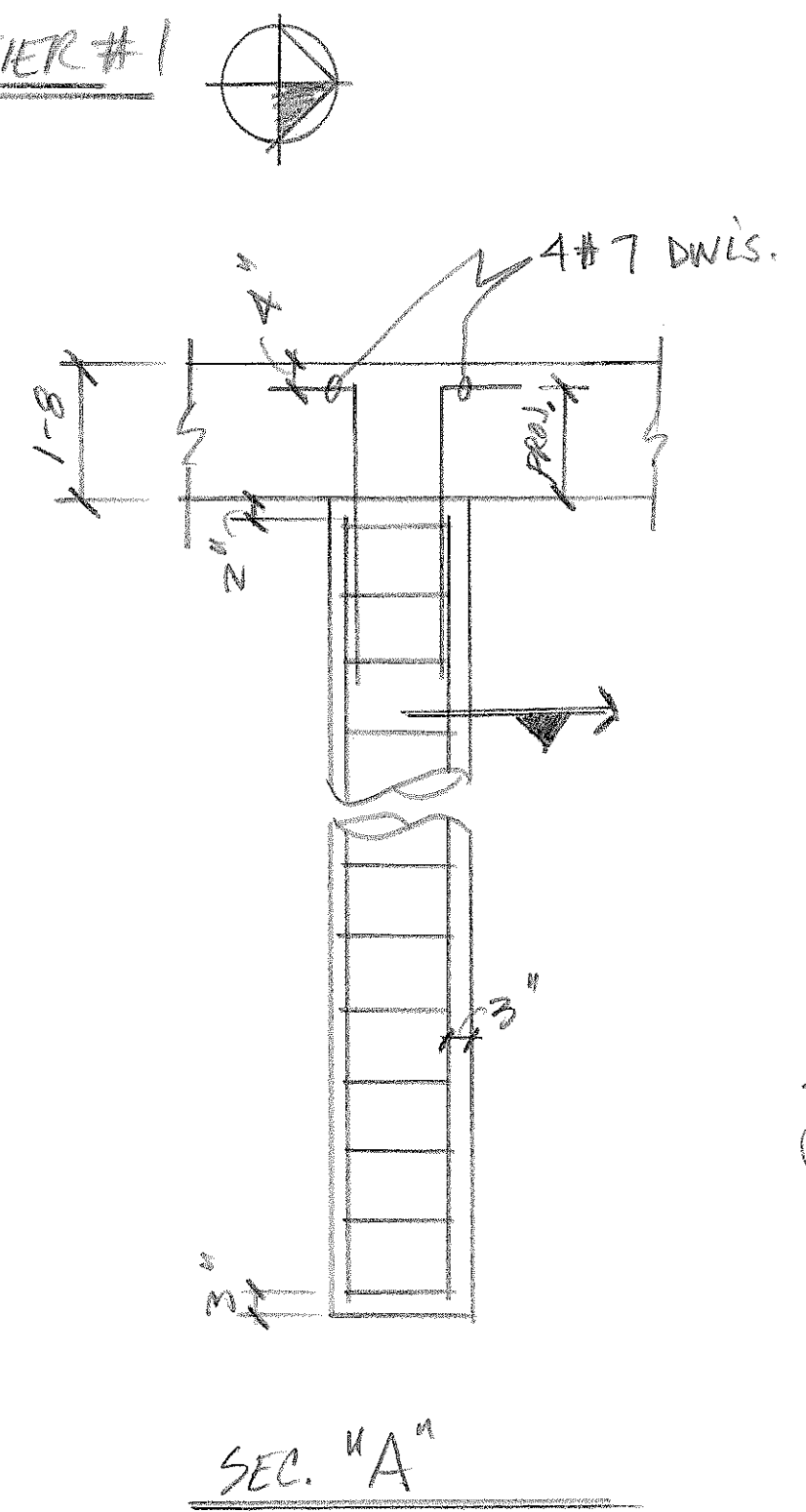

SEC. "A"

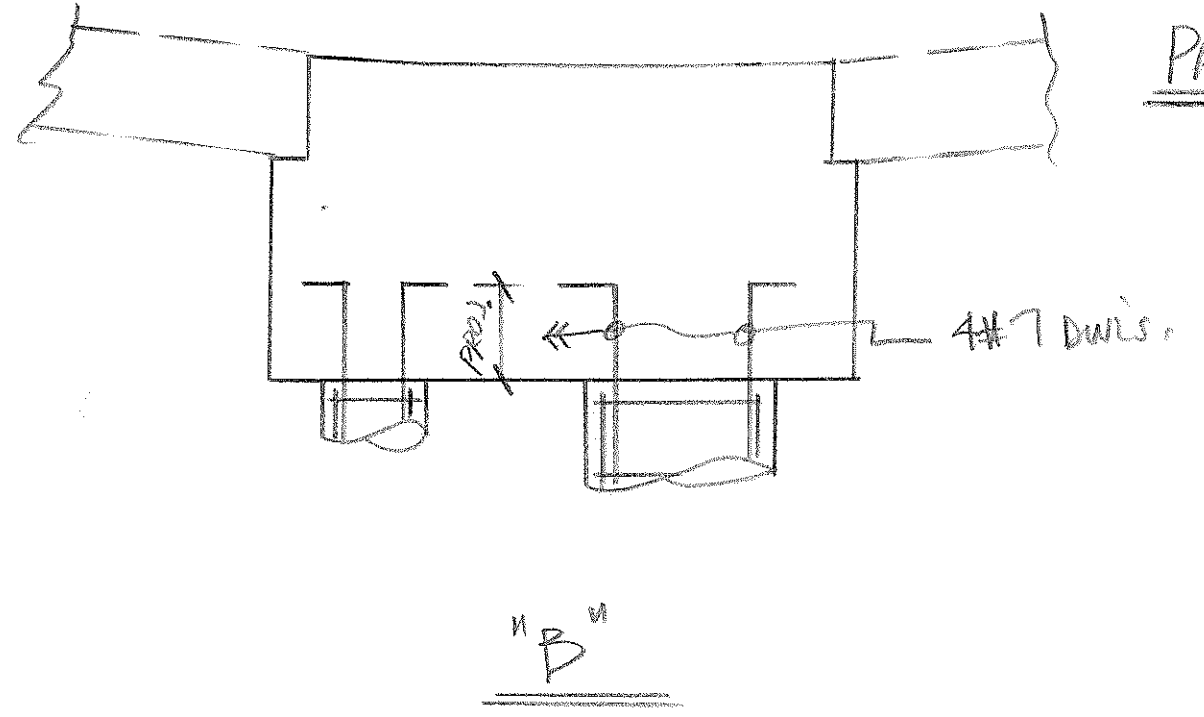

SEC. "B"

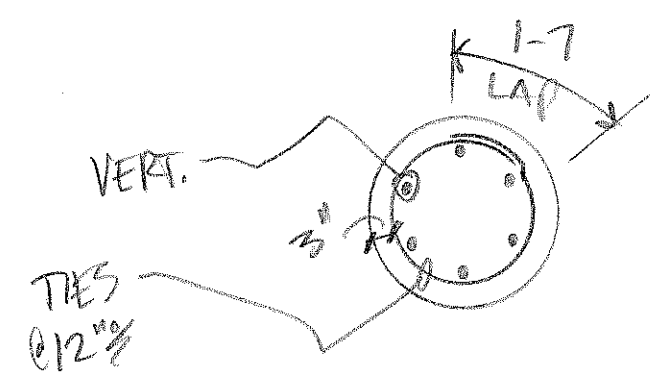

PIER SEC.  
NOTE: NO ALIGNMENT BARS REQ'D.

LEGEND

- O.F. - OUTSIDE FACE
- I.F. - INSIDE FACE
- E.F. - EACH FACE
- HORIZ. - HORIZONTAL
- VERT. - VERTICAL
- DWLS. - DOWELS
- FTG. - FOOTING
- ELEV. - ELEVATION
- E.W. - EACH WAY
- T.O.F. - TOP OF FOOTING
- B.O.F. - BOTTOM OF FOOTING
- T.O.W. - TOP OF WALL
- B.O.W. - BOTTOM OF WALL
- GRD. BM. - GRADE BEAM
- MK. - MARK
- MAS. - MASONRY
- DIAG. - DIAGONAL
- COL. - COLUMN
- PROJ. - PROJECTION
- T & B - TOP & BOTTOM
- N.F. - NEAR FACE
- F.F. - FAR FACE
- % - ON CENTER
- @ - AT EACH

NO.	DATE	ISSUED FOR
AREA CODE 303 371-3950 3730 SALEM ST. DENVER, COLO. 80239		
JOB HAROLD D. THOMPSON RES. WATER RECLAIM.		
LOCATION FOUNTAIN, CO.		
DESCRIPTION PIER PLAN & SECONDARY CLARIFIER #1 & #2		
CONTRACTOR WEAVER CONST.		
ARCHITECT GMS, INC.		
DRAWN: D. TARIN	CHECKED:	DATE: 2/7/10
REVISIONS	JOB NO. 10082	DRAWING NO. P13