



Weaver

CONSTRUCTION MANAGEMENT

3679 S Huron Street, Suite 404 Englewood, Colorado 80110

Phone: (303) 789-4111 FAX: (303) 789-4310

SUBMITTAL TRANSMITTAL

July 6, 2012

Submittal No: 03200-020

PROJECT: **Harold Thompson Regional WRF**
Birdsall Rd.
Fountain, CO 80817
Job No. 2908

ENGINEER: **GMS, Inc.**
611 No. Weber St., #300
Colorado Springs, CO 80903
719-475-2935 Roger Sams

OWNER: **Lower Fountain Metropolitan
Sewage Disposal District**
901 S. Santa Fe Ave.
Fountain, CO 80817
719-382-5303 James Heckman

CONTRACTOR: **Dalco Industries Inc.**
3730 Salem Street
Denver, CO 80239
303-371-3950 David Tarin

SUBJECT: Foundation Plan @ Blower Building (BB-1)

SPEC SECTION: 03200 - Concrete Reinforcement

PREVIOUS SUBMISSION DATES:

DEVIATIONS FROM SPEC: ___ YES X NO

CONTRACTOR'S STAMP: This submittal has been reviewed by Weaver Construction Management and, unless indicated otherwise, has been found to be in conformance with the intent of the contract documents.

Contractor's Stamp:

Engineer's Stamp:

Date: 7/6/12

Reviewed by: Jeff Burst

(X) Reviewed Without Comments

() Reviewed With Comments

ENGINEER'S
COMMENTS:

10" 2-10 401	10" 4-10 402	10" 2-0 403	10-3 604	8 1/2" 8 1/2" 8 1/2" 305	1-6 1-6 1-6 306
1-6 1-6 1-6 307	2-0 2-0 508	8" 4-8 409	8" 15-0 8" 410	8" 8-0 8" 411	

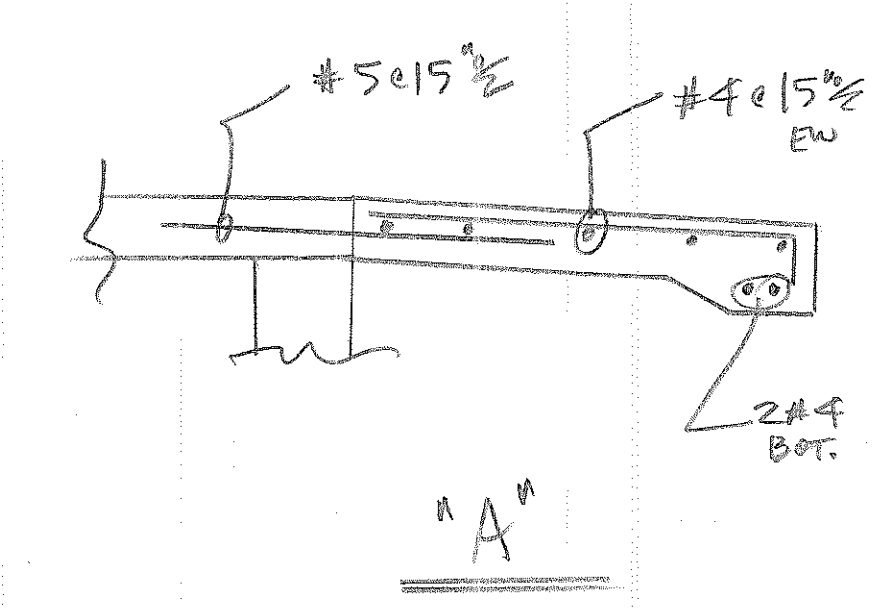
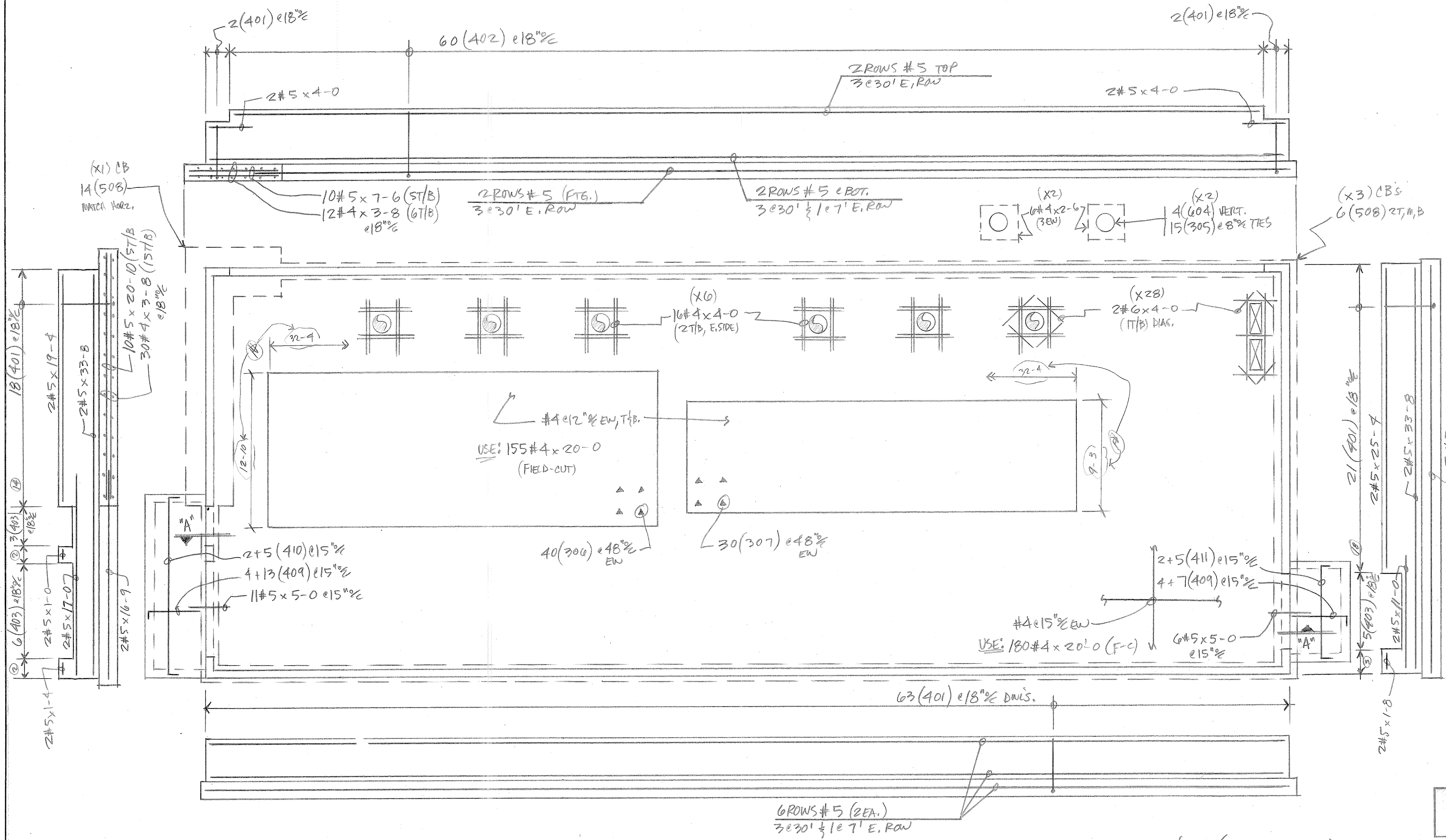

LAP (32d)
#4-1-7
#5-2-0

6 ROWS #5 (2EA.)
3 e 30' 1/2 | e 7' E. ROW

FOUND. PLAN (BLOWER BLDG.)
NTS

<small>AREA CODE 303 371-9950</small>		<small>3720 SALEM ST. DENVER, CO. 80239</small>
<small>7-1512</small> <small>HDTNWTP</small> <small>FOUNTAIN, CO.</small>	<small>D. TARIN</small>	
<small>FOUND. BLOWER BLDG.</small>		<small>BB-1</small>