



Weaver

CONSTRUCTION MANAGEMENT

3679 S Huron Street, Suite 404 Englewood, Colorado 80110

Phone: (303) 789-4111 FAX: (303) 789-4310

SUBMITTAL TRANSMITTAL

March 1, 2012

Submittal No: 05500-010

PROJECT: **Harold Thompson Regional WRF**
Birdsall Rd.
Fountain, CO 80817
Job No. 2908

ENGINEER: **GMS, Inc.**
611 No. Weber St., #300
Colorado Springs, CO 80903
719-475-2935 Roger Sams

OWNER: **Lower Fountain Metropolitan
Sewage Disposal District**
901 S. Santa Fe Ave.
Fountain, CO 80817
719-382-5303 James Heckman

CONTRACTOR: **American Fabricators, Inc**
10290 E. 106th Ave.
Brighton, Co 80601
303-296-6223 Chuck Allen
amerfab@msn.com

SUBJECT: Misc Metals @ WYE Structure - WCM Comments, Shop Drawings SD-01, SD-02 & SD-03

SPEC SECTION: 05500 - Metal Fabrications

PREVIOUS SUBMISSION DATES:

DEVIATIONS FROM SPEC: ___ YES X NO

CONTRACTOR'S STAMP: This submittal has been reviewed by Weaver Construction Management and, unless indicated otherwise, has been found to be in conformance with the intent of the contract documents.

Contractor's Stamp:

Date: 3/1/12

Reviewed by: Tyler Ammerman

() Reviewed Without Comments

(X) Reviewed With Comments

Engineer's Stamp:

ENGINEER'S
COMMENTS: _____



Project: HDTWRF Project

Location: Fountain, CO

Supplier: American Fabricators Inc.

Date: 3/1/12

Submittal for: 5500-010 - Wye Structure misc. metals

Submittal Review Comments:

- 1. Reference page G-19**

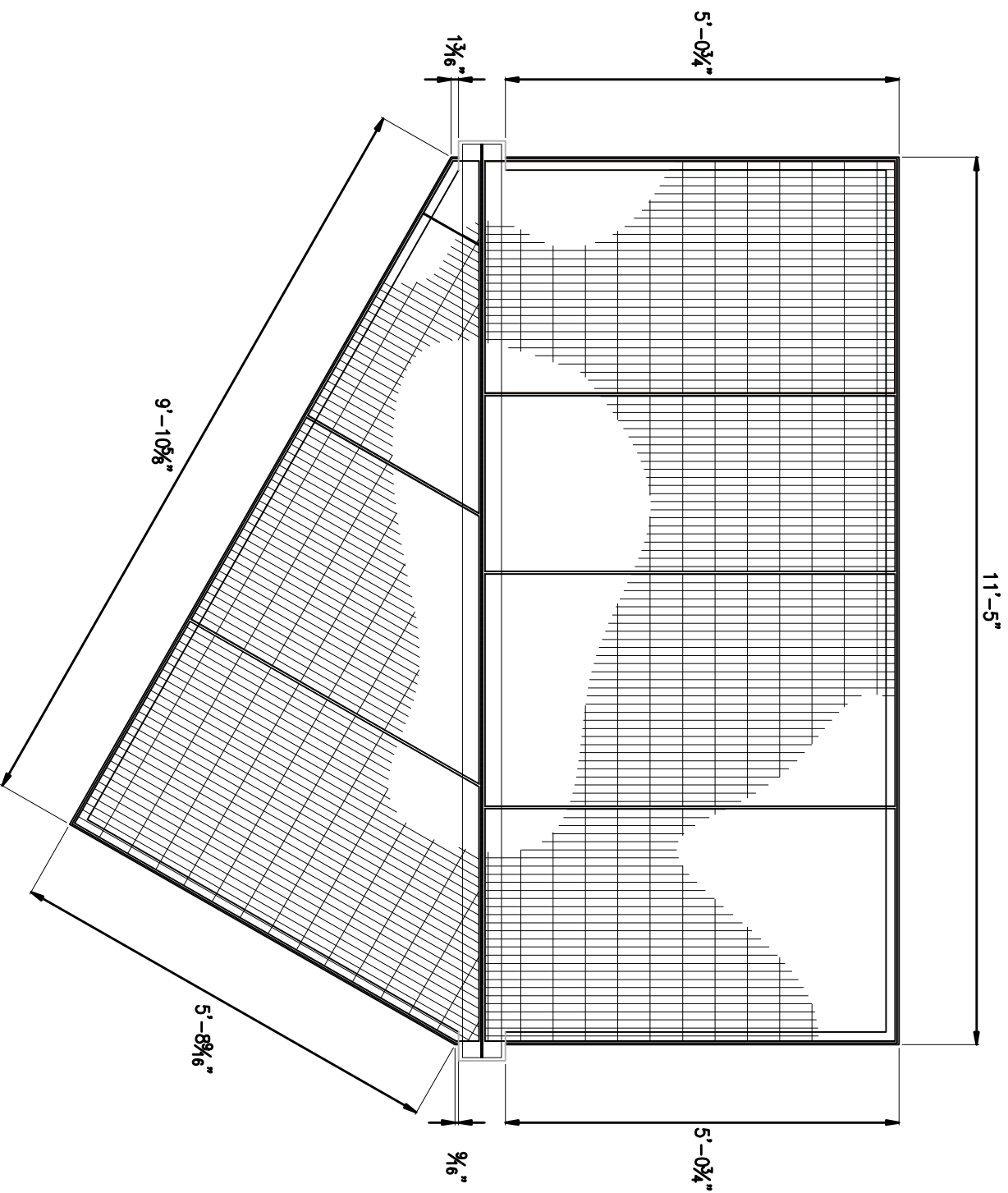

- Notes:**
1. Beam conforms to ASTM A572/A992 Gr. 50 steel.
 2. Embed angle is 6061-T6 Aluminum. Angles will be coated with tar coat on concrete contact sides.

1 WYE Structure Embed Plan

CONTRACTOR:
Weaver General Construction Co.
 3679 S. Huron St. Suite 404
 Englewood, CO 80110
 Ph: (303)769-4111 / Fx: (303)769-4310

FABRICATOR:
Anderson Fabricators
 14220 E. 142nd Ave.
 Englewood, Colorado 80151
 Ph: (303)769-4111 / Fx: (303)769-4310

PROJECT: **HD Thompson Change Order III**
 TITLE: **WYE Structure Embed**

Revision:	DATE:	DWG BY:	CHK BY:
1. -	JAN 31 2012	CCA	EDO
2. -			
3. -			
4. -			
5. -			

SHEET NUMBER: **SD - 01**

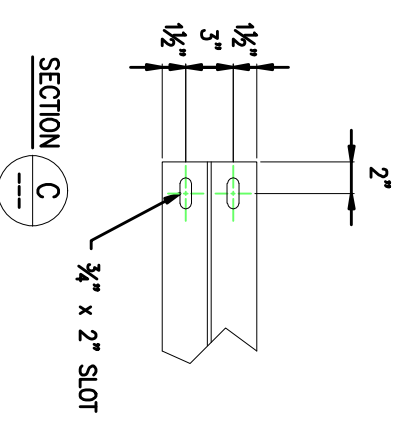
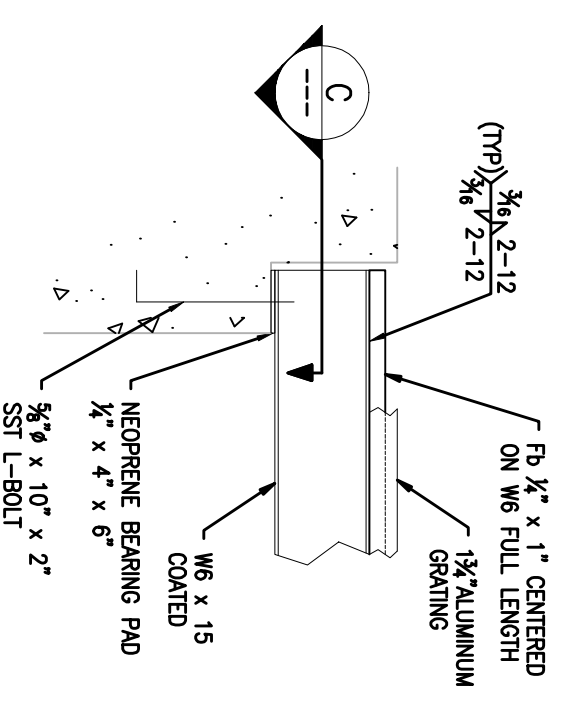
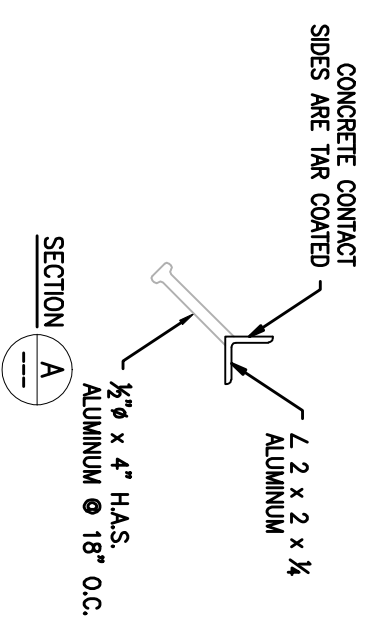
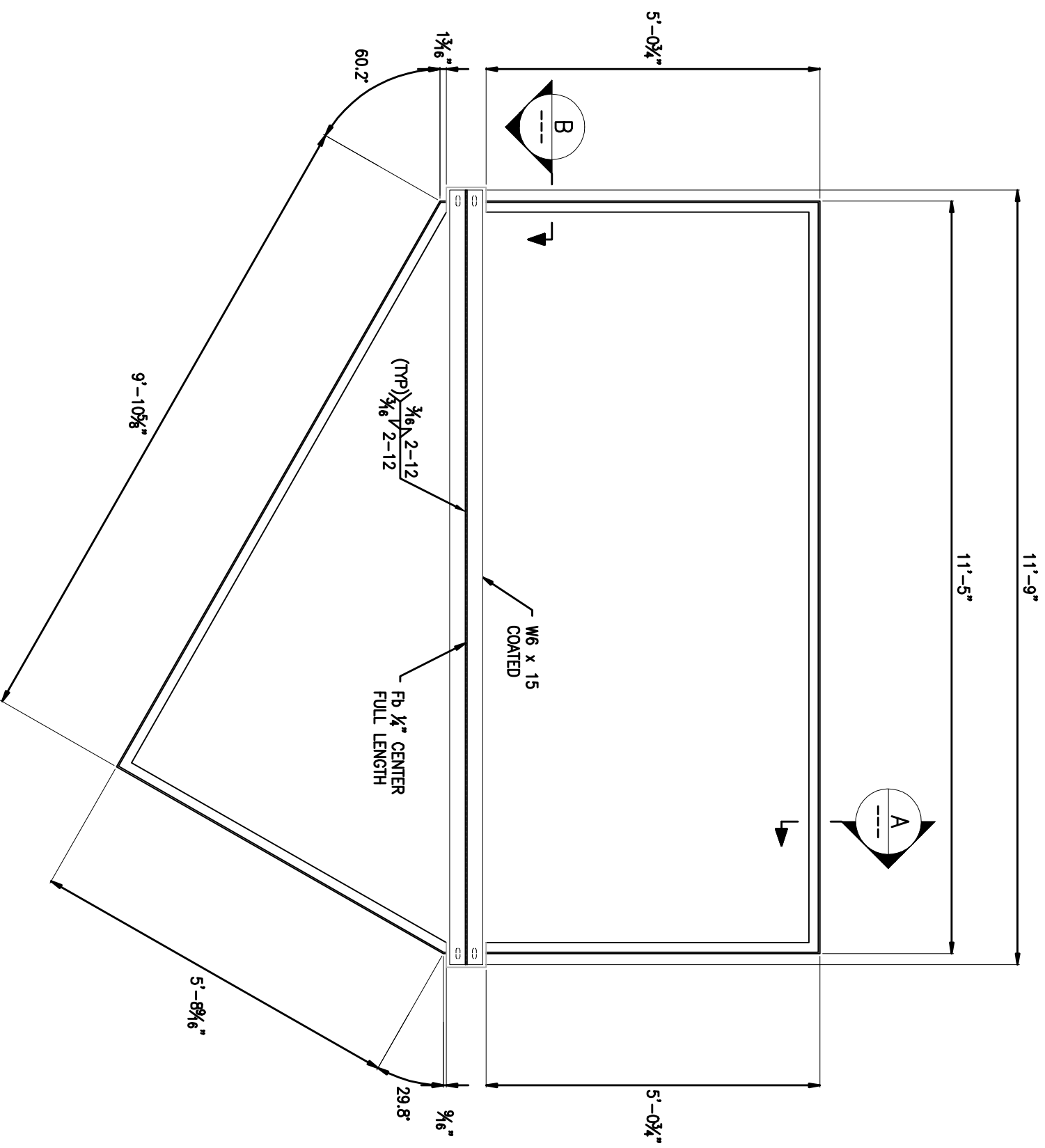

1 WYE Structure Elevation and Sections

CONTRACTOR:
Weaver General Construction Co.
 3679 S. Huron St. Suite 404
 Englewood, CO 80110
 Ph: (303)769-4111 / Fx: (303)769-4310

FABRICATOR:
Amason Fabricators
 14200 E. 140th Ave.
 Englewood, Colorado 80150
 Ph: (303)769-4111 / Fx: (303)769-4310

PROJECT: **HD Thompson Change Order III**
 TITLE: **Elevations and Section**

Revision:	CHK. BY:	DATE:
1. -	CCA	JAN 31 2012
2. -		
3. -		
4. -		
5. -		

DWG. BY: CCA
 SHEET NUMBER: **SD - 02**

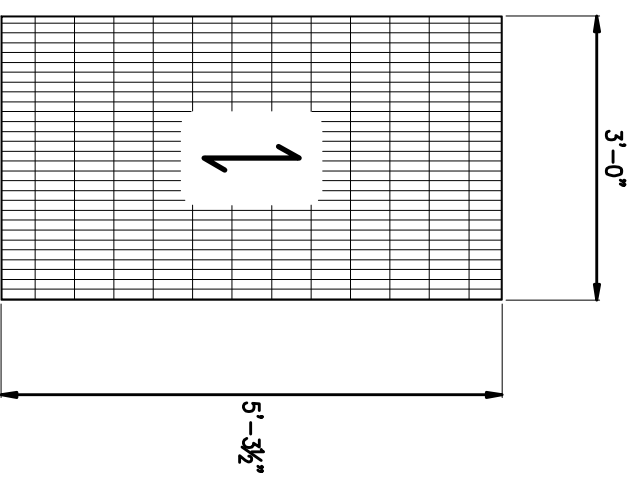

1 3/4" x 1/4" ALUMINUM I-BAR
GRATE 1 3/8" O.C. (19-SI 4)
(3X)

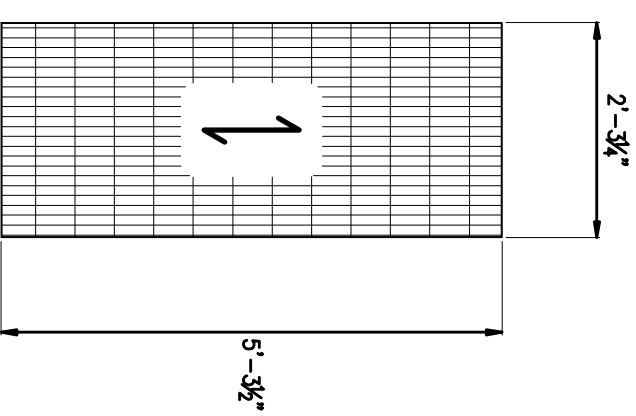

1 3/4" x 1/4" ALUMINUM I-BAR
GRATE 1 3/8" O.C. (19-SI 4)
(1X)

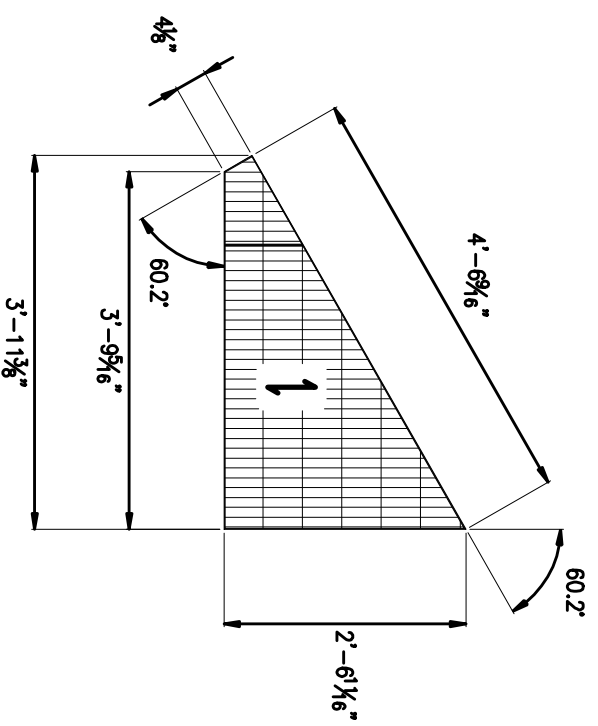

1 3/4" x 1/4" ALUMINUM I-BAR
GRATE 1 3/8" O.C. (19-SI 4)
(1X)

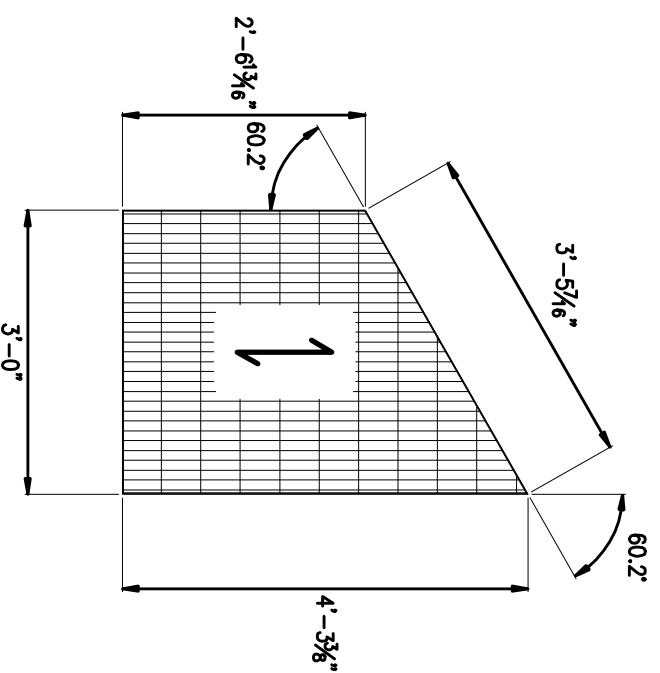

1 3/4" x 1/4" ALUMINUM I-BAR
GRATE 1 3/8" O.C. (19-SI 4)
(1X)

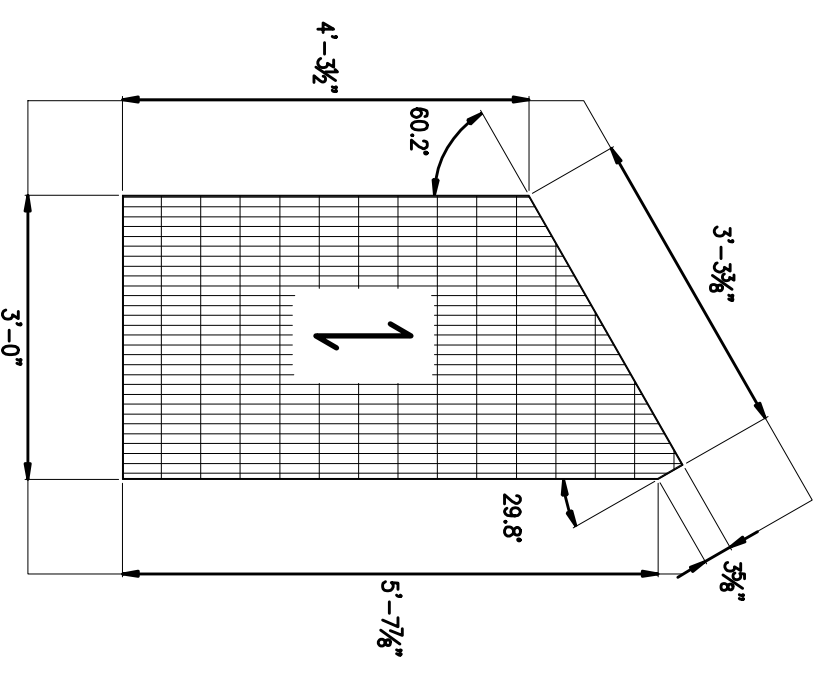

1 3/4" x 1/4" ALUMINUM I-BAR
GRATE 1 3/8" O.C. (19-SI 4)
(1X)

1 WYE Structure Grating Elevations

CONTRACTOR:
Weaver General Construction Co.
3679 S. Huron St. Suite 404
Englewood, CO 80110
Ph: (303)769-4111 / Fax: (303)769-4310

FABRICATOR:
Amadson Fabrications
14200 E. 140th Ave.
Englewood, Colorado 80151
Ph: (303)769-4310 / Fax: (303)769-4310

PROJECT: **HD Thompson Change Order III**
TITLE: **WYE Structure Grating**

Revision:	DATE:	DWG BY:	CHK BY:
1. -	JAN 31 2012	CCA	EDO
2. -			
3. -			
4. -			
5. -			

SHEET NUMBER: **SD - 03**