



Weaver

CONSTRUCTION MANAGEMENT

3679 S Huron Street, Suite 404 Englewood, Colorado 80110

Phone: (303) 789-4111 FAX: (303) 789-4310

SUBMITTAL TRANSMITTAL

August 7, 2012

Submittal No: 07501-005

PROJECT: **Harold Thompson Regional WRF**
Birdsall Rd.
Fountain, CO 80817
Job No. 2908

ENGINEER: **GMS, Inc.**
611 No. Weber St., #300
Colorado Springs, CO 80903
719-475-2935 Roger Sams

OWNER: **Lower Fountain Metropolitan
Sewage Disposal District**
901 S. Santa Fe Ave.
Fountain, CO 80817
719-382-5303 James Heckman

CONTRACTOR: **Heath Steel**
141 Racquette Dr
Fort Collins, CO 80522
970-490-8031 Randy Gates
rgates@heathsteel.com

SUBJECT: Submittal for the Blower Building Metal Roof Panels

SPEC SECTION: 07501

PREVIOUS SUBMISSION DATES:

DEVIATIONS FROM SPEC: ___ YES x NO

CONTRACTOR'S STAMP: This submittal has been reviewed by Weaver Construction Management and, unless indicated otherwise, has been found to be in conformance with the intent of the contract documents.

Contractor's Stamp:

Engineer's Stamp:

Date: 8/7/12

Reviewed by: Adam Roeder

(X) Reviewed Without Comments

() Reviewed With Comments

ENGINEER'S
COMMENTS:

SECTION 07501

METAL ROOF ~~AND WALL~~ PANELS

PART 1 – GENERAL

1.1 SUMMARY

- A. Section Includes: Factory-formed metal roof ~~and wall~~ panels, including fascia, ~~soffit~~ and other trim panels
- B. Related Sections
 - 1. Section 06100: Carpentry
 - 2. Section 07200: Insulation
 - 3. Section 07600: Flashing and Sheet Metal
 - 4. Section 07900: Joint Sealants
 - 5. Section 13121: Prefabricated Metal Building

1.2 REFERENCES

- A. American Society for Testing and Materials (ASTM)
 - 1. ASTM A653 Standard Specification for Steel Sheets, Zinc-Coated (Galvanized) or Zinc-Iron Alloy-Coated (Galvannealed) by the Hot-Dip Process
 - 2. ASTM D2247 Standard Practice for Testing Water Resistance of Coatings in 100% Relative Humidity
 - 3. ASTM E283 Standard Test Method for Determining the Rate of Air Leakage Through Exterior Windows, Curtain Walls, and Doors Under Specified Pressure Differences Across the Specimen
 - 4. ASTM E331 Standard Test Method for Water Penetration of Exterior Windows, Skylights, Doors, and Curtain Walls by Uniform Static Air Pressure Difference
 - 5. ASTM E1646 Standard Test Method for Water Penetration of Exterior Metal Roof Panel Systems by Uniform Static Air Pressure Difference
 - 6. ASTM E1680 Standard Test Method for Rate of Air Leakage Through Exterior Metal Roof Panel Systems
- B. Underwriters Laboratories, Inc. (UL)
 - 1. UL 580 Tests for Uplift Resistance of Roof Assemblies
 - 2. UL 2218 Standard for Safety for Impact Resistance of Prepared Roof Covering Materials

1.3 SYSTEM DESCRIPTION

- A. Design Requirements
 - 1. Refer to the Design Criteria given on the Drawings

2. All products designed, fabricated and installed according to the 2011 Pikes Peak Regional Building Code
- B. Provide metal roof ~~and wall~~ panels which have been manufactured, tested, fabricated and installed according to the following criteria
1. ASTM A653
 2. ASTM D2247
 3. ASTM E283
 4. ASTM E331
 5. ASTM E1646
 6. ASTM E1680
 7. UL 580
 8. UL 2218

1.4 SUBMITTALS

- A. General: In accordance with Section 01340
- B. Product Data: Submit manufacturer's product data and installation instructions
- C. Shop Drawings
1. Provide drawings indicating panel layout, project specific construction details and related information
 2. Submit complete fabrication, assembly and installation drawings
 3. Submit detailed specifications and data describing materials, parts, devices and accessories
 4. Submit data for verification of compliance with specifications and to illustrate construction and assembly of products
 - a. Dimensions
 - b. Materials
 - c. Thickness or gages
 - d. Fasteners
 - e. Finishes
 - f. Sealants
 5. Door, window and equipment rough opening details and layouts fully dimensioned
- D. Samples
1. Color charts: Manufacturer's factory standard colors, finishes and textures
- E. Quality Assurance
- ~~1. Submit Manufacturer's certificate that products meet or exceed specified requirements.~~
- Heath Steel has updated this specification for approval for the Magna-Loc roof system to be used on the Blower Building.
- F. Closeout Submittals
1. Warranty documents specified herein

1.5 QUALITY ASSURANCE

- ~~A. Installer Qualifications: The installer shall have demonstrated experience on projects of similar size and complexity~~ Installation is by others

1.6 DELIVERY, STORAGE AND HANDLING

- A. Deliver materials in manufacturer's original, unopened, undamaged containers with identification labels intact
- B. Store materials protected from exposure to harmful environmental conditions and at temperature and humidity conditions recommended by the manufacturer
- C. Materials damaged during delivery, storage and handling or by the elements shall be restored to new condition or replaced

1.7 WARRANTY

- A. Manufacturer's Warranty: Submit, for Owner's acceptance, manufacturer's standard warranty document executed by authorized company official. Manufacturer's warranty is in addition to, and not a limitation of, other rights Owner may have under contract documents
 - 1. Warranty Period for Finish: 20 years beginning with date of substantial completion

PART 2 – PRODUCTS

2.1 METAL ROOF PANELS

- A. Panel Types
 - 1. Structural standing seam roof panels
 - ~~2. Embossed tile facsimile roof panels~~
- B. Material: Full hard steel, galvanized, primed, coated
- C. Material Standard: ASTM A653 or ASTM A792
- D. Minimum thickness
 - 1. Structural standing roof seam panels: 24 gauge
 - ~~2. Embossed tile facsimile roof panels: 26 gauge~~
- E. Yield Strength: 50,000 psi
- F. Configuration
 - 1. Panels to be installed over solid substrate ~~or open framing~~
 - ~~a. Coordinate with pre-engineered metal building supplier for spacing requirements of purlins and other support members~~ Wood frame building by others.

- b. Refer to Drawings
- 2. Structural standing seam roof panels
 - a. Nominal panel width: 18" inches; total panel width may vary to accommodate manufacturer's standard, 2'-0" to 4'-0"
 - b. Nominal panel seam height: 1 3/4 inches 2"
 - c. Smooth panel face without ribs or striations
 - d. Side seams
 - 1) Continuous interlocking, snap lock or mechanically crimped
 - 2) Include factory installed sealant
 - 3) Utilize concealed roof clips
 - a) Specifically designed for roof panel system
 - b) Allow for thermal movement of roof panel system
- ~~3. ETF panels

 - a. Simulate clay roofing tiles
 - b. Nominal panel width: 36 inches
 - c. Nominal tile corrugation dimensions: 7" wide x 12" long x 1 1/2" high
 - d. Each panel to include alignment ridges, fasteners, dimples and factory-profiled end cuts for seam mating~~
- 4. Provide single panel coverage from peak to eave or ridge, hip to eave

G. Finish

- 1. Factory applied, baked on finish of Kynar® 500 or equal
- 2. Minimum coating thickness: 1.0 mils
- 3. Owner to select color from manufacturer's standard color palette

H. Trim and Accessories

- 1. Manufacturer's standard configuration
- 2. One-piece factory formed panels
- 3. Match roof slope
- 4. Panel closures and rib covers to match panel profile
- 5. Eave and soffit trim
 - a. Refer to Drawings for dimensions and configurations
 - b. Manufacturer's standard eave trim acceptable in lieu of framed soffit
 - c. ~~Coordinate with pre-engineered building supplier for eave construction~~
- ~~6. Transition rib or tile covers at all changes in roof pitch~~
- ~~7. Provide ice and water shield membrane as recommended by manufacturer~~
- 8. Gutters and downspouts
 - a. Manufacturer's standard configurations
 - b. Size and location as indicated on Drawings
 - 1) Conform size to local code requirements
 - c. Downspouts to be full box configuration
 - d. Galvanized steel with factory paint finish
 - e. Galvanized steel gutter hangers as required
 - f. Gutters configured to avoid damage from snow and ice falling off roof
 - 1) Position gutters below roof plane as indicated on Drawings
 - ~~2) Provide ice breaks where gutter position is not below roof plane~~
 - g. Pre-formed closures and seals
- 9. Fasteners
 - a. Screw fasteners with integral waterproofing washer/gasket

- 1) Wood screw or self-drilling sheet metal depending on substrate material
 - b. UL 90 concealed panel clips and substrate screws, zinc plated
 - c. Pop rivets where recommended by manufacturer, stainless steel
 - d. All exposed fasteners to have finish matching roof panels
 - ~~e. Exposed fasteners permitted for trim members only~~
10. Refer to Paragraph 2.3 for additional requirements

First row of screws at eave are exposed. See drawings and the installation manual.

I. Design Basis

Magna-Loc by Metal Sales Mfg.

- ~~1. Structural standing seam roof panels: Fabral, Inc. Thin Seam roofing system~~
- ~~2. Embossed tile facsimile roof panels: Met-Tile, Inc. Met-Tile roofing system~~
- 3. Equivalent products of other manufacturers may be accepted subject to compliance with design, function, materials and performance of the specified items
 - a. Compliance shall be determined by the Engineer based upon review of proposed equipment prior to bidding
 - b. It will be the manufacturer's or supplier's responsibility to coordinate and furnish, for review by Engineer, complete product data and specifications verifying complete conformance with the specified items

2.2 METAL WALL PANELS See previous submittal for wall panel.

~~A. Smooth faced exterior wall panels to be same as roof panels~~

B. Textured Exterior Wall Panels

- ~~1. Material: ASTM A446, G90 galvanized~~
- ~~2. Minimum thickness: 20 gauge~~
- ~~3. Configuration

 - ~~a. 16 inch maximum coverage width~~
 - ~~b. Flush appearance with minor inset groove at seam~~
 - ~~c. Textured finish~~
 - ~~d. Concealed fasteners~~~~
- ~~4. Fasteners

 - ~~a. Exposed fasteners permitted for trim members only~~
 - ~~b. Through panel flange fasteners to have weather seal washers~~
 - ~~c. No. 410 stainless steel conforming to Fed. Spec. QQ-5-763C~~~~
- ~~5. Endlaps: Not permitted~~
- ~~6. Panel finish

 - ~~a. Polymer/aggregate finish~~
 - ~~b. Owner's choice of colors from manufacturer's standard colors

 - ~~1) Refer to Drawings for multiple color or texture requirements in any given exterior wall extent, i.e., accent or rustication strips~~~~~~
- ~~7. Design basis

 - ~~a. Varco Pruden "Texture Clad" wall system~~
 - ~~b. Custom Panel Systems "Stucco Building Panel" system~~
 - ~~c. Or equal~~~~
- ~~8. Equivalent products of other manufacturers may be accepted subject to compliance with design, function, materials and performance of the specified items~~

- a. Compliance shall be determined by the Engineer based upon review of proposed equipment prior to bidding
- b. It will be the manufacturer's or supplier's responsibility to coordinate and furnish, for review by Engineer and Owner, complete product data and specifications verifying complete conformance with the specified items

C. Interior Wall and Ceiling Panels

- 1. Material: ASTM A653, G90 galvanized
- 2. Minimum thickness: 29 gauge
- 3. Configuration
 - a. Nominal panel coverage width: 36 inches
 - b. Trapezoidal rib profile
 - 1) Nominal rib height: 5/8 inches
 - 2) Nominal rib spacing: 9 inches
 - 3) Intermediate striations per manufacturer's standard products
 - c. Smooth finish
 - d. Exposed fasteners
 - e. Capable of being installed over open framing or solid substrate
- 4. Fasteners
 - a. Galvanized steel for dry, conditioned spaces
 - b. Stainless steel for humid spaces
 - c. Provide seal washers for all fasteners
- 5. End laps are not permitted
 - a. Refer to Drawings for panel length/height required
- 6. Panel finish
 - a. Factory applied polyester finish
 - b. Paint finish warranty of 15 years for dry, conditioned spaces
 - c. Owner's choice of manufacturer's standard color palette
 - 1) Submit standard color palette including white, ivory and light beige
- 7. Design basis
 - a. Metal Sales Manufacturing Corp., Pro-Panel II
 - b. Or equal
 - c. Equivalent products of other manufacturers may be accepted subject to compliance with design, function, materials and performance of the specified items
 - 1) Compliance shall be determined by the Engineer based upon review of proposed equipment prior to bidding
 - 2) It will be the manufacturer's or supplier's responsibility to coordinate and furnish, for review by Engineer, complete product data and specifications verifying complete conformance with the specified items

2.3 ACCESSORIES

- A. Provide all system accessory components required, including but not limited to the following
 - 1. Ridge, hip and peak caps
 - 2. Rakes and corners
 - 3. Base guard trim

4. Fascia trim
5. Eave trim
6. Gable trim
7. Sidewall and end wall trim
8. Drip cap
9. Flashing and counter flashing
10. Trim at all required door, window and equipment locations
11. ~~One piece~~ fascia and soffit
12. Inside and outside closures
13. Lap sealant tape
14. Sill flashing at all required openings
15. Rain caps and flashing at all flue and vent penetrations
16. Other trim as required for building accessories as shown on the Drawings

PART 3 – EXECUTION Installation is by others

3.1 MANUFACTURER'S INSTRUCTIONS

- A. Comply with the instructions and recommendations of the roof and wall panel manufacturer

3.2 EXAMINATION

- A. Site Verification of Conditions
 1. Verify that site conditions are acceptable for installation of roof and wall panels and accessories
 2. In order to ensure panels seal at side laps, ensure that structure is square and true before beginning panel installation
 3. Do not proceed with installation of roof and wall panels until unacceptable conditions are corrected

3.3 PREPARATION

- A. Coordination: Coordinate metal roofing and wall panel work with other work including drainage to provide a non-corrosive and leakproof installation
- B. Dissimilar Metals: Prevent galvanic action of dissimilar metals

3.4 INSTALLATION

- A. General: Install metal roofing and wall panels to profiles, patterns and drainage indicated and as required for leakproof installation
 1. Provide for structural and thermal movement of work
 2. Seal joints for leakproof installation
 3. Provide uniform, neat seams
 4. Conceal fasteners where possible in exposed work. Cover and seal fasteners and anchors for watertight and leakproof installation
 5. Provide sealant-type joints where necessary. Form joints to conceal sealant.

B. Wall Panel Installation

1. Install panels plumb, true and square to correct alignment with framing, in accordance with shop drawings and manufacturer's printed installation instructions
2. Do not attach panels to improperly seasoned or damp lumber
3. Cut only one panel sheet at a time, exposed side down, away from other unused or installed panels
4. Clean panel area of all shavings before installation

C. Roof Panel Installation

1. Face side laps away from prevailing wind
2. Lay first sheet along eave at downwind side of roof, farthest away from direction of prevailing winds
3. Install inside closures to prevent bird nesting or insect infestation at openings
4. Protect against wind uplift and provide finished appearance by applying rake trim or gable trim
5. Install ridge cap to prevent leakage. Seal off ridge and panel using closure strip
6. In order to prevent corrosion, immediately remove loose metal shavings and debris such as leaves or dirt left on the roof surface

D. Screw Installation

1. When pre-drilling fastener holes, use a cover sheet to prevent hot shavings from adhering to panels
2. Use appropriate screw fasteners for substrate material
3. Torque fasteners according to manufacturer's instructions
4. Compress integral washer/gasket per manufacturer's instructions; do not under or over compress gasket
5. Install fasteners without distorting panel surfaces

3.5 CLEANING

A. Upon completion of panel installation

1. Remove temporary coverings and protection of adjacent work areas.
2. Repair or replace damaged installed products
3. Clean installed products in accordance with manufacturer's instructions prior to Owner's acceptance
4. Remove and legally dispose of construction debris from project site

3.6 PROTECTION

- ### A. Protect installed work from damage due to subsequent construction activity on the site

END OF SECTION



HEATH STEEL
P.O. BOX 473
141 RACQUETTE DR.
FORT COLLINS, CO 80522
(970) 490-8031

HAROLD D. THOMPSON
REGIONAL WATER RECLAMATION FACILITY
BLOWER BUILDING
14641 LOWER FOUNTAIN HEIGHTS, FOUNTAIN, CO

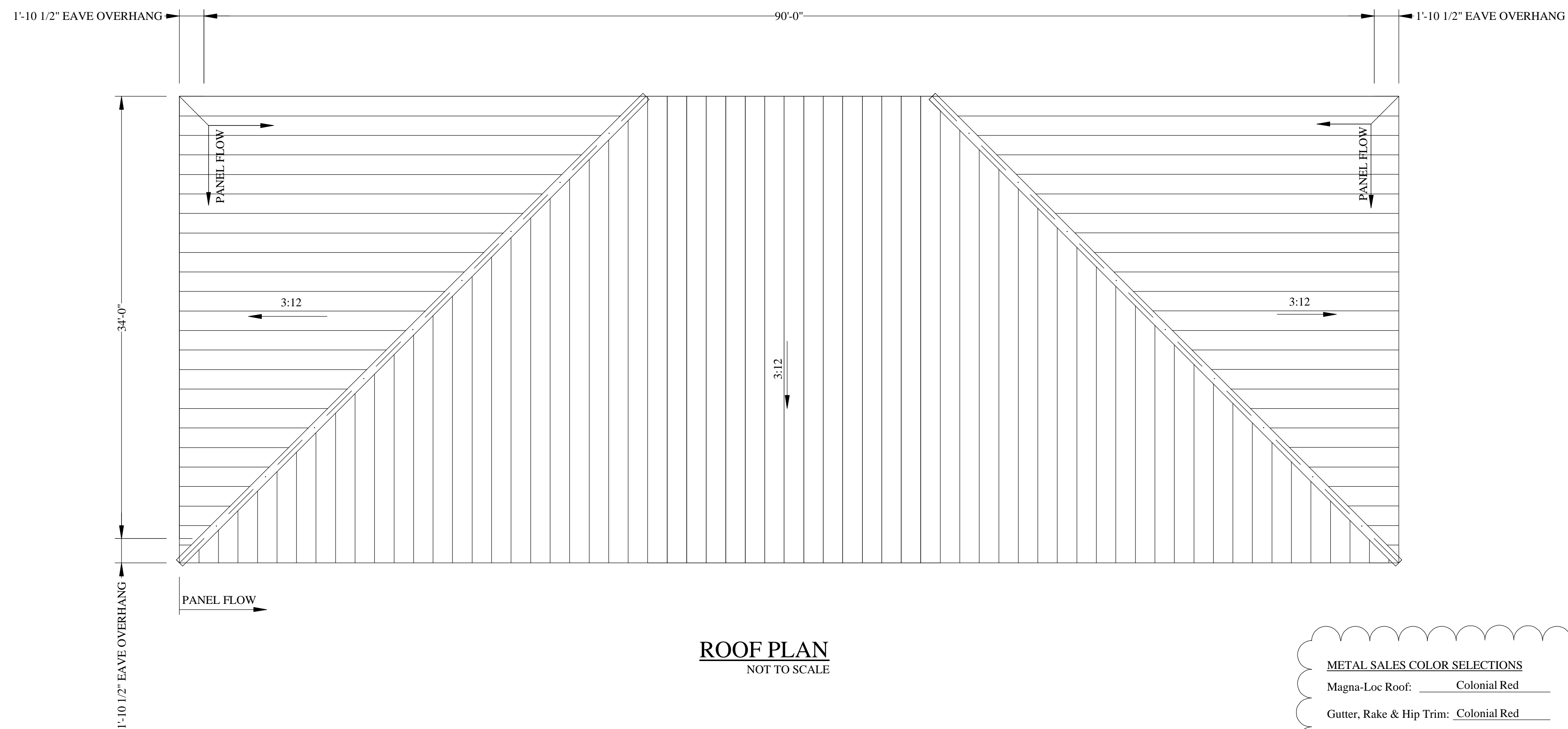

ROOF PLAN
NOT TO SCALE

- ROOFING GENERAL NOTES:**
- 1) Prior to roof installation, it is the responsibility of the installer to familiarize themselves with the Metal Sales Installation Manual for the Magna-Loc product.
 - 2) Reference the Metal Sales Magna-Loc Installation Guide for all standard details.
 - 3) Gutter support straps are required at 1'-6" on center (every roof seam) at all eaves.
 - 4) Install (7) each downspout drops with elbows per the architectural elevations.
 - 5) Field cut panels as required along the hip per this plan and the manufacturer's installation manual.
 - 6) Field miter and seal the eave gutter at the outside corners as required.
 - 7) Field fabricate plugs from the flat sheets provided at the ends of the hip cap.

METAL SALES COLOR SELECTIONS

Magna-Loc Roof:	Colonial Red
Gutter, Rake & Hip Trim:	Colonial Red
Downspouts:	Colonial Red

ENGINEER OF RECORD: PLEASE REVIEW THE ROOF CLIP FASTENER PULL-OUT VALUE AND SPECIFY THE REQUIRED ROOF CLIP ROW SPACING BASED ON THIS PULL-OUT VALUE AND THE PROPERTIES OF THE ROOF PLYWOOD SHEATHING THAT IS TO BE USED.

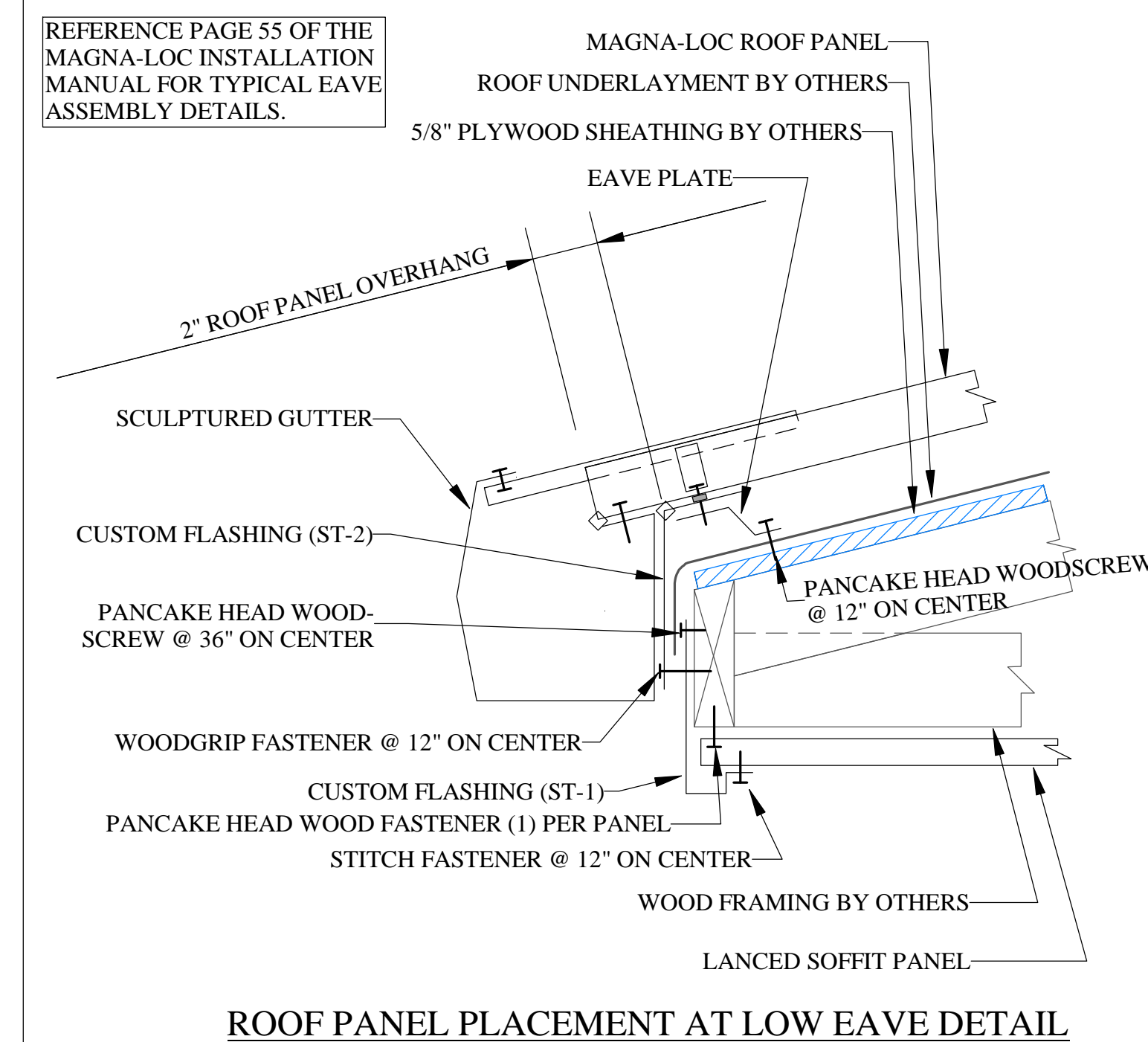

ROOF PANEL PLACEMENT AT LOW EAVE DETAIL

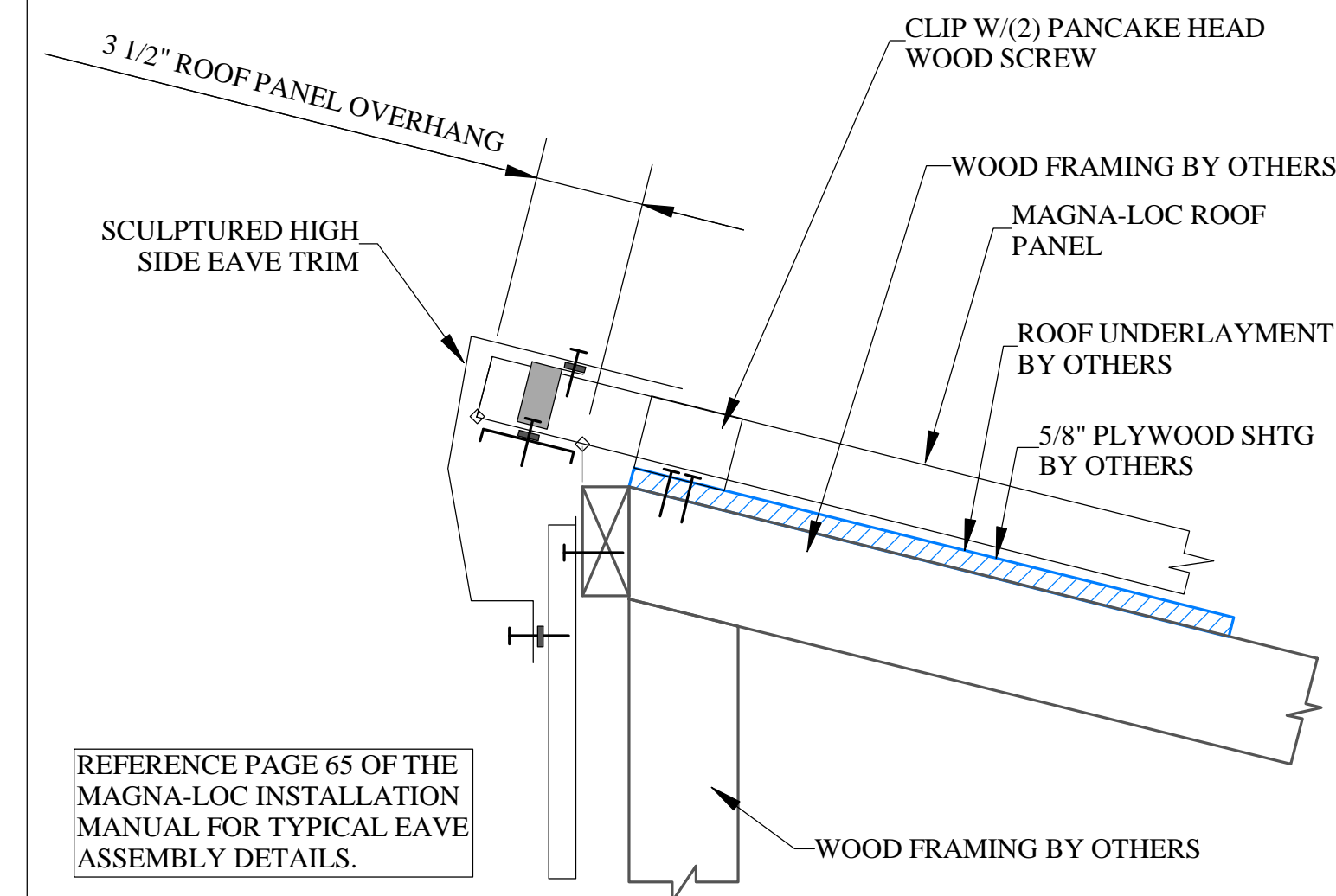

ROOF PANEL PLACEMENT AT HIGH EAVE DETAIL

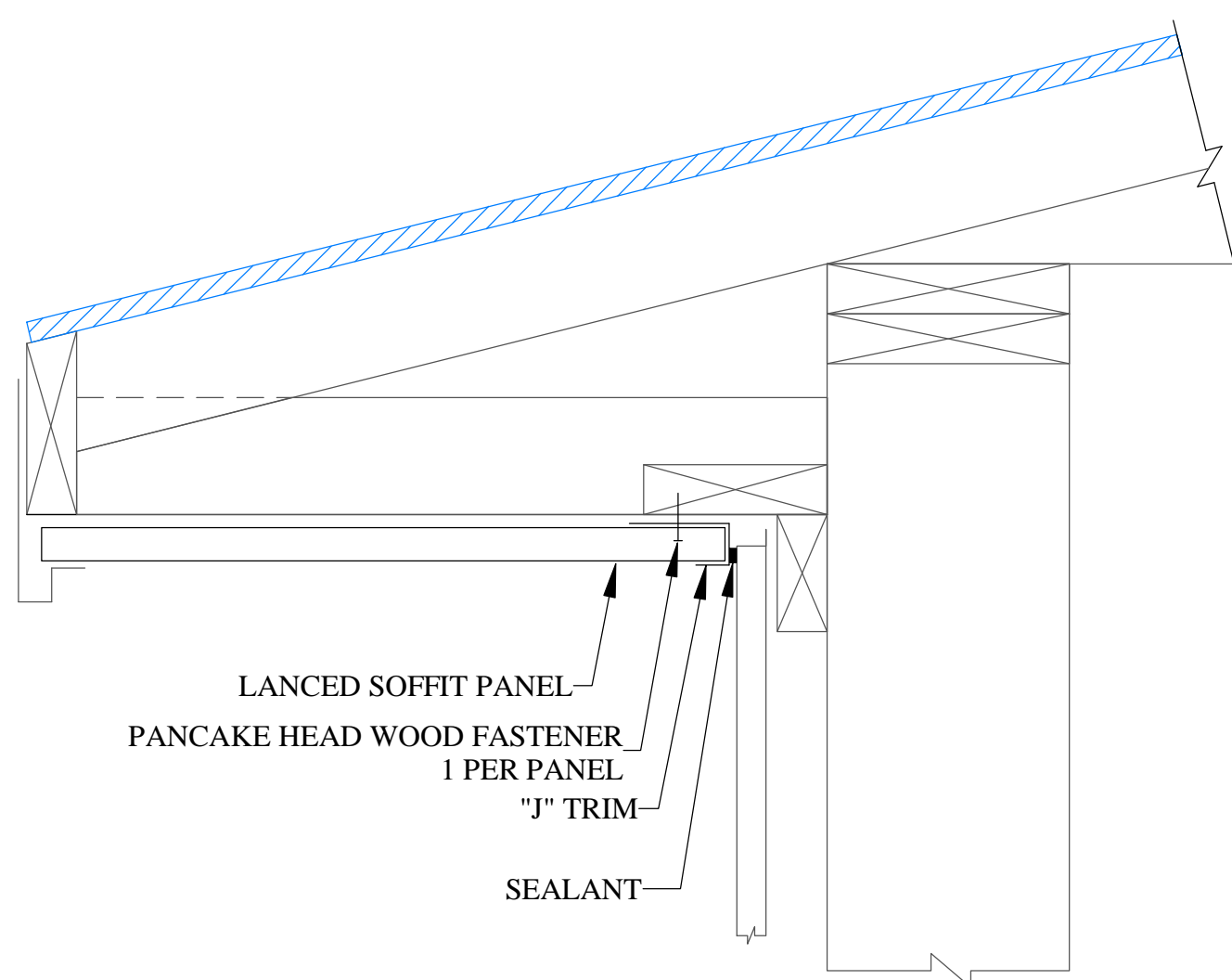

TYPICAL SOFFIT AT WALL PANEL DETAIL

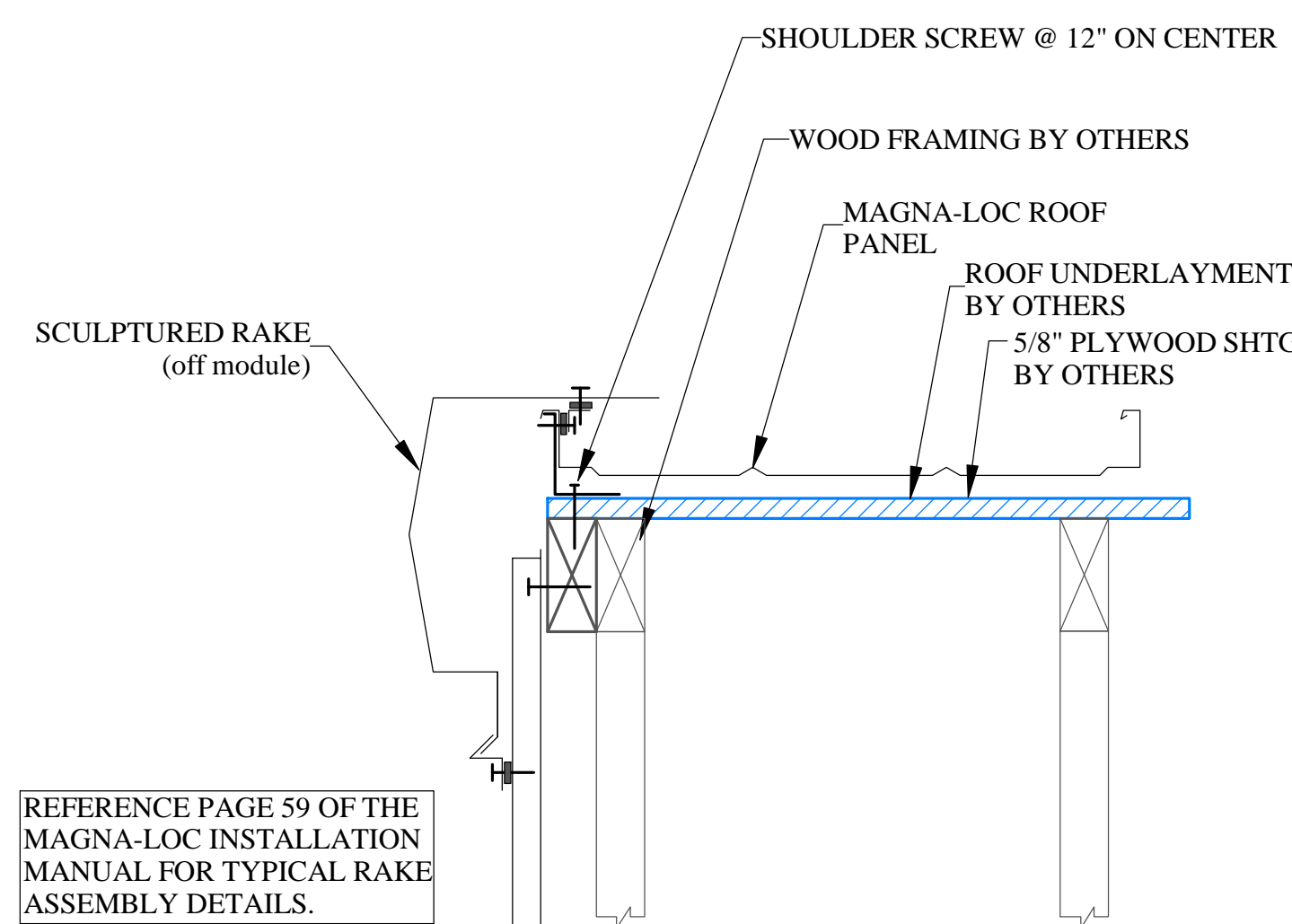

ROOF PANEL PLACEMENT AT RAKE DETAIL

REFERENCE PAGE 59 OF THE MAGNA-LOC INSTALLATION MANUAL FOR TYPICAL RAKE ASSEMBLY DETAILS.

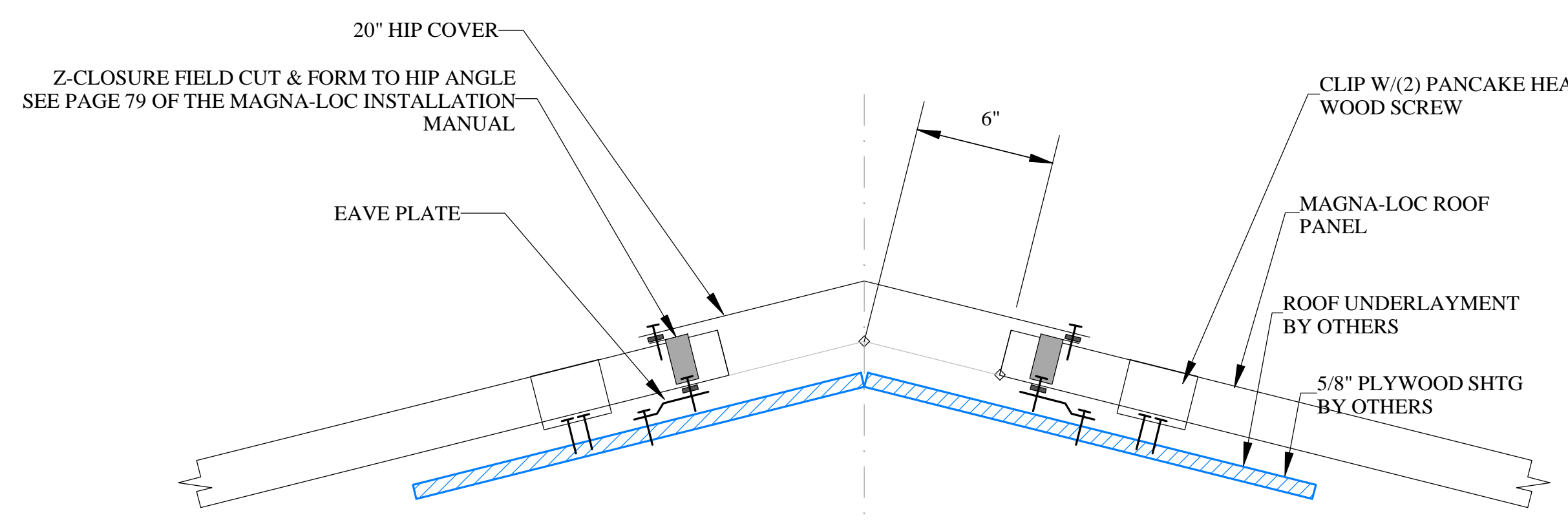

ROOF PANEL PLACEMENT AT HIP DETAIL

REFERENCE PAGE 76 OF THE MAGNA-LOC INSTALLATION MANUAL FOR TYPICAL HIP ASSEMBLY DETAILS.

ISSUED FOR: APPROVAL
DATE: JULY 31, 2012

RS1 of 1
ROOF SHEETING

The application and detail drawings in this manual are strictly for illustration purposes and may not be applicable to all building designs or product installations. All projects should conform to applicable building codes for that particular area. It is recommended to follow all building regulations and standard industry practices.

Metal Sales Manufacturing Corporation is not responsible for the performance of the roof system if it is not installed in accordance with the suggested instructions referenced in this manual. If there is a conflict between this manual and the approved Metal Sales' erection drawings, the approved erection drawings are to take precedence.

Prior to ordering and installing materials, all dimensions should be verified by field measurements.

Oil canning is not a cause for rejection. Oil canning can be described as the amount of waviness found in the flat areas of metal panels. Oil canning is an inherent characteristic of light gauge cold formed metal products, particularly those with broad flat areas. There are many factors which may contribute to oil canning that Metal Sales is not able to control. These factors include: misalignment of the support system, over driving of fasteners used on the panels, stress (whether inherent in the panel or induced), thermal expansion and contraction of the panel, material handling, width, gauge, length, color of panels, and installation. (Reference Metal Construction Association "Oil Canning Position Paper" - Appendix A).

Metal Sales reserves the right to modify, without notice, any details, recommendations or suggestions. Any questions you may have regarding proper installation of the Magna-Loc roofing system should be directed to your Metal Sales representative, (see pages 2 and 3).

Consult Metal Sales for any additional information not outlined in this manual.

This manual is designed to be utilized as a guide when installing Magna-Loc roofing system. It is the responsibility of the erector to ensure the safe installation of this product system.

SAFETY

STUDY APPLICABLE OSHA AND OTHER SAFETY REQUIREMENTS BEFORE FOLLOWING THESE INSTRUCTIONS.

The installation of metal roof systems is a dangerous procedure and should be supervised by trained knowledgeable erectors. **USE EXTREME CARE WHILE INSTALLING ROOF PANELS.** It is not possible for Metal Sales to be aware of all the possible job site situations that could cause an unsafe condition to exist. The erector of the roof system is responsible for reading these instructions and determining the safest way to install the roof system.

These instructions are provided only as a guide to show a knowledgeable, trained erector the correct parts placement one to another. If following any of the installation steps would endanger a worker, the erector should stop work and decide upon a corrective action.

Provide required safety railing, netting, or safety lines for crew members working on the roof.

Do not use the roof panel as a walking platform. The roof panels will not withstand the weight of a person standing at the edge of the panel.

Do not stand on any part of a roof panel until the panel has been completely attached.

ms metal sales
manufacturing corporation

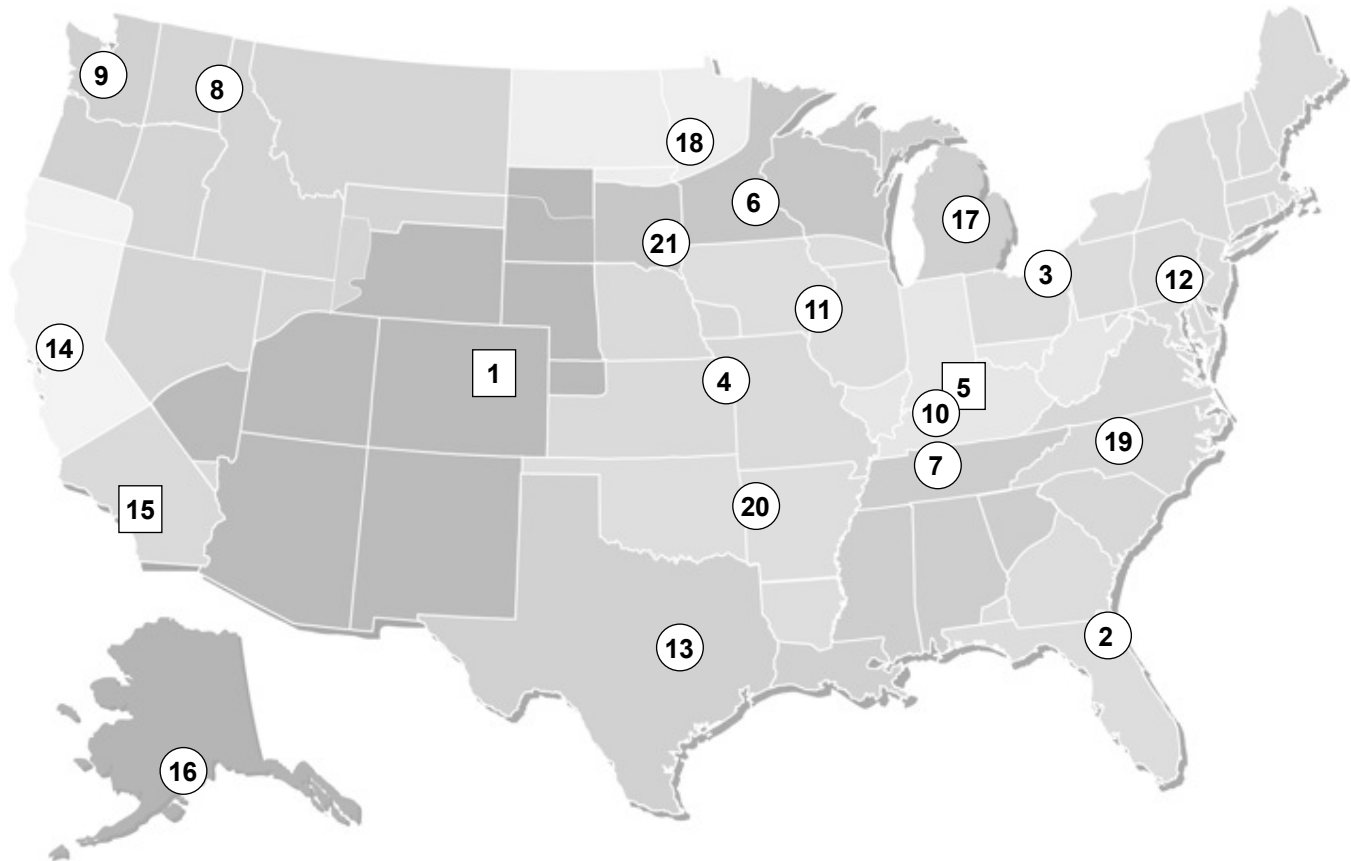

★NOTE: Shaded areas represent regions served by each location.



Indicates Metal Sales branch manufactures Magna-Loc Panels

Metal Sales offers a complete line of metal roof, wall, and fascia panel systems for the commercial, architectural, industrial, residential, and agricultural markets. Metal Sales offers over 75 profiles with a wide selection of widths, colors, and gauges - new construction or retrofit.

1.) DENVER BRANCH

7990 E. I-25 Frontage Road
Longmont, CO 80504
303.702.5440 Phone
800.289.7663 Toll Free
800.289.1617 Toll Free Fax

2.) JACKSONVILLE BRANCH

7110 Stuart Avenue
Jacksonville, FL 32254
904.783.3660 Phone
800.394.4419 Toll Free
904.783.9175 Fax
800.413.3292 Toll Free Fax

3.) JEFFERSON BRANCH

352 East Erie Street
Jefferson, OH 44047
440.576.9070 Phone
800.321.5833 Toll Free
440.576.9242 Fax
800.233.5719 Toll Free Fax

4.) INDEPENDENCE BRANCH

1306 S. Powell Road
Independence, MO 64057
816.796.0900 Phone
800.747.0012 Toll Free
816.796.0906 Fax

5.) SELLERSBURG BRANCH

7800 State Road 60
Sellersburg, IN 47172
812.246.1866 Phone
800.999.7777 Toll Free
812.246.0893 Fax
800.477.9318 Toll Free Fax

6.) ROGERS BRANCH

22651 Industrial Blvd.
Rogers, MN 55374
763.428.8080 Phone
800.328.9316 Toll Free
763.428.8525 Fax
800.938.9119 Toll Free Fax

7.) NASHVILLE BRANCH

4314 Hurricane Creek Blvd.
Antioch, TN 37013
615.641.7100 Phone
800.251.8508 Toll Free
615.641.7118 Fax
800.419.4372 Toll Free Fax

8.) SPOKANE BRANCH

East 2727 Trent Avenue
Spokane, WA 99202
509.536.6000 Phone
800.572.6565 Toll Free
509.534.4427 Fax

9.) SEATTLE BRANCH

20213 84th Avenue, South
Kent, WA 98032
253.872.5750 Phone
800.431.3470 Toll Free (Outside WA)
800.742.7900 Toll Free (Inside WA)
253.872.2008 Fax

10.) NEW ALBANY BRANCH

999 Park Place
New Albany, IN 47150
812.944.2733 Phone
812.944.1418 Fax

11.) ROCK ISLAND BRANCH

8111 West 29th Street
Rock Island, IL 61201
309.787.1200 Phone
800.747.1206 Toll Free
309.787.1833 Fax

12.) DEER LAKE BRANCH

29 Pinedale Industrial Road
Orwigsburg, PA 17961
570.366.2020 Phone
800.544.2577 Toll Free
570.366.1648 Fax
800.544.2574 Toll Free Fax

13.) TEMPLE BRANCH

3838 North General Bruce Dr.
Temple, TX 76501
254.791.6650 Phone
800.543.4415 Toll Free
254.791.6655 Fax
800.543.4473 Toll Free Fax

14.) WOODLAND BRANCH

1326 Paddock Place
Woodland, CA 95776
530.668.5690 Phone
800.759.6019 Toll Free
530.668.0901 Fax

15.) FONTANA BRANCH

14213 Whittram Avenue
Fontana, CA 92335
909.829.8618 Phone
800.782.7953 Toll Free
909.829.9083 Fax

16.) ANCHORAGE BRANCH

4637 Old Seward Hwy.
Anchorage, AK 99503
907.646.7663 Phone
866.640.7663 Toll Free
907.646.7664 Fax

17.) BAY CITY BRANCH

5209 Mackinaw Road
Bay City, MI 48706
989.686.5879 Phone
888.777.7640 Toll Free
989.686.5870 Fax
888.777.0112 Toll Free Fax

18.) DETROIT LAKES BRANCH

1435 Egret Avenue
Detroit Lakes, MN 56501
218.847.2988 Phone
888.594.1394 Toll Free
218.847.4835 Fax
888.594.1454 Toll Free Fax

19.) MOCKSVILLE BRANCH

188 Quality Drive
Mocksville, NC 27028
336.751.6381 Phone
800.228.6119 Toll Free
336.751.6301 Fax
800.228.7916 Toll Free Fax

20.) FORT SMITH BRANCH

7510 Ball Road
Fort Smith, AR 72908
479.646.1176 Phone
877.452.3915 Toll Free
479.646.5204 Fax

21.) SIOUX FALLS BRANCH

2700 West 3rd Street, Suite 4
Sioux Falls, SD 57104
605.951.0367 Phone
888.902.8320 Toll Free

TECHNICAL SUPPORT**TECHNICAL SERVICES**

545 South 3rd Street
Louisville, KY 40202
502.855.4300 Phone
800.406.7387 Toll Free
502.855.4290 Fax
800.944.6884 Toll Free Fax

General Information	PAGE NO.
Important Information	1
Metal Sales' Locations	2
Customer Service	3
Table of Contents	4 & 5
Color Codes	6
Flashing Angle Chart	7
Panel Profiles	
90° Panel Profiles	8
180° Panel Profiles	9
180° Curved Panel Profiles	10
Accessory Profiles	11-14
Flashing Profiles	15-21
Fastener Selection Guide	22
Fastener Technical Information	
Physical Properties	23
Pull Out Strength Values	24
Pull Over Strength Values	25
UL 580 Wind Uplift Information	26-30
UL 263 Fire Resistance Rating	30
Section Properties and Load Tables	31
Handling Material	
Receiving Material	32
General Handling	32
Mechanical Handling	32
Manual Handling	33
Storage	
General	34
Storage on Roof	35
Foot Traffic	36
Field Cutting and Touch-up	
Field Cutting	37
Touch-up Paint	37
Design / Installation Considerations	
Fastener Installation Technique	38
Condition of Substructure	38
Ventilation	39
Insulation	39
System Expansion / Contraction	40
Selection of System Components	40
Factory Notching and Prepunching	41
Installation Procedure Overview	42
Installation of Panel	
<i>Installation of Floating Rake Zee</i>	43
<i>Installation of Eave Plate</i>	44
<i>Installing First Panel</i>	45
<i>Installing Panel Clips</i>	46
<i>Endlapping of Panel</i>	47-48
<i>Sidelapping of Panel</i>	49-50
<i>Termination of Panel</i>	51
<i>Seaming Panels</i>	52-53
Installation of Panel Over Open Framing	
Sculptured Eave	54
Sculptured Gutter	55
4.5" Drop Valley	56
9" Drop Valley	57
Endlap	58
SSR Sculptured Rake (On Module)	59
SSR Sculptured Rake (Off Module)	60

	PAGE NO.
Installation of Panel Over Open Framing (cont.)	
Rakewall (On Module)	61
Rakewall (Off Module)	62
Expansion Joint	63
Pitch Break With Wall Panel	64
Sculptured High Side Eave	65
SSR Ridge	66
20" Ridge / Hip Cover	67
Vented Ridge	68
Installation of Panel Over Decking	
Eave Offset	69
Box Gutter Offset	70
Valley Offset	71
Rake (On Module)	72
Rake (Off Module)	73
Rakewall	74
Peak	75
20" Ridge / Hip Cover Fixed	76
Vented Ridge	77
Installation of End Dam	78
Installation of Z-Closures	79
Clip Detail	80
Transition Detail	81
Hemming Detail	82
Roof Penetrations	
General Notes	83
Installation Notes.....	83
Care and Maintenance	84
Notes	85

When placing an order, be sure to include the description of the product being ordered along with its product number. All product numbers consist of a minimum of seven (7) digits. You will notice throughout our price book that some parts have a seven (7) digit number and others have five (5) digits with two blanks. These two blanks are to be filled in with a designated color code (see below for color codes).

See Metal Sales Color Guides for color and gauge selections.

For example: Magna-Loc Product Number 2835273 means this part is designated to be color code 73 (Patriot Red).

PVDF (Kynar 500®) Color	SR	TE	SRI
Aged Copper (65)	0.32	0.85	32
Antique Patina (M1)	0.38	0.85	40
Ash Grey (25)	0.38	0.86	41
Brandywine (P8)	0.26	0.85	24
Champagne Metallic (168)	0.47	0.85	53
Classic Green (66)	0.32	0.86	33
Colonial Red (W75)	0.35	0.86	37
Copper Penny (W92)	0.45	0.85	50
Dark Bronze (50)	0.30	0.86	30
Felt Green (W66)	0.31	0.84	31
Galvalume (41)	0.67	0.14	56
Hemlock Green (M7)	0.36	0.85	38
Khaki (88)	0.35	0.87	37
Linen White (81)	0.73	0.86	89
Mansard Brown (133)	0.30	0.87	31
Matte Black (106)	0.27	0.86	26
Medium Bronze (H4)	0.30	0.87	31

PVDF (Kynar 500®) Color	SR	TE	SRI
Metallic Silver (K7)	0.60	0.77	68
Mistique Plus (W31)	0.34	0.82	34
Ocean Blue (35)	0.29	0.86	29
Old Town Grey (W25)	0.40	0.85	43
Old Zinc Grey (W29)	0.42	0.85	46
Parchment (W74)	0.41	0.86	45
Patina Green (W58)	0.46	0.85	51
Patriot Red (73)	0.46	0.86	52
Regal Blue (W35)	0.27	0.86	26
River Teal (59)	0.29	0.86	29
Sandstone (W51)	0.54	0.86	63
Slate Grey (W38)	0.30	0.85	30
Snowdrift White (W81)	0.65	0.85	78
Tahoe Blue (W71)	0.30	0.86	30
Taupe (74)	0.29	0.84	28
Terra Cotta (W72)	0.39	0.85	42
Weathered Copper (W50)	0.32	0.84	32

SR = Solar Reflectance

TE = Thermal Emittance

SRI = Solar Reflectance Index

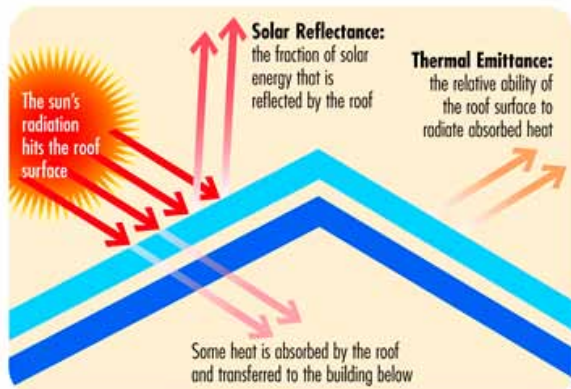

All Colors meet or exceed Steep Slope ENERGY STAR Requirements

This chart should be used to determine the specified angle.

PROFILE/FLASHING	1/4":12	1/2":12	1:12	2:12	3:12	4:12	5:12	6:12	7:12	8:12
RIDGE SSR RIDGE VENTED RIDGE COVER	178°	175°	170°	161°	152°	143°	*135°	*127°	*120°	*113°
HIP VALLEY	178°	177°	173°	167°	160°	154°	148°	143°	138°	134°
EAVE EXTENDED EAVE SCULPTURED EAVE	91°	92°	95°	99°	104°	108°	113°	117°	120°	124°
SSR SCULPTURED HIGH SIDE EAVE	99°	98°	95°	91°	86°	82°	*77°	*73°	*70°	*66°
PEAK	89°	88°	85°	81°	76°	72°	67°	63°	60°	56°
PITCH BREAK HIGH SIDE PITCH BREAK	91°	92°	95°	99°	104°	108°	113°	117°	120°	124°
GUTTER DRIP BOX GUTTER	91°	92°	95°	99°	104°	108°	113°	117°	120°	124°

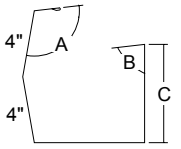
SSR SCULPTURED GUTTER			1/4":12	1/2":12	1:12	2:12	3:12	4:12	5:12	6:12	7:12	8:12
	A		101°	102°	105°	109°	114°	118°	123°	127°	130°	134°
	B		89°	88°	85°	81°	76°	72°	67°	63°	60°	56°
PROFILE	RIB HT.											
MAGNA-LOC	2"	C	5 ⁵ / ₈ "	5 ³ / ₄ "	6"	6 ¹ / ₂ "	7"	7 ¹ / ₂ "	8"	8 ¹ / ₂ "	9"	9 ¹ / ₂ "

*Note: Metal Sales standard flashing dimensions may not accommodate all situations, please inquire about custom flashings with slopes 6:12 or greater.

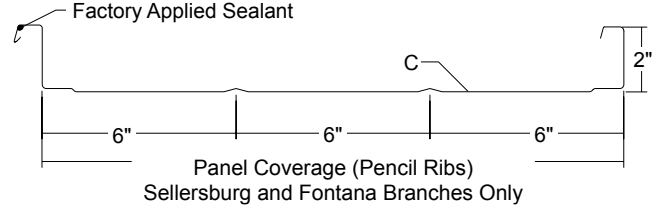
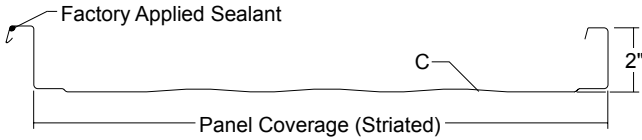
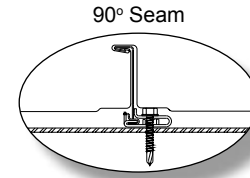
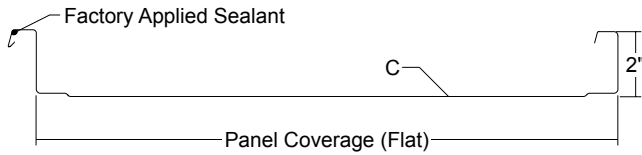

FINISH	GAUGE	COVERAGE	PRODUCT NO.	WT/SQ
ACG (Flat)	24	16"	2735141	130
ACG (Striated)	24	16"	2735241	130
ACG (Pencil Rib)	24	16"	2785041	130
PVDF Standard*(Flat)	24	16"	28351__	130
PVDF Standard*(Striated)	24	16"	28352__	130
PVDF Standard*(Pencil Rib)	24	16"	28850__	130
ACG (Flat)	22	16"	2935141	161
ACG (Striated)	22	16"	2935241	161
ACG (Pencil Rib)	22	16"	2985041	161
PVDF* (Flat)	22	16"	30351__	161
PVDF* (Striated)	22	16"	30352__	161
PVDF* (Pencil Rib)	22	16"	30850__	161
ACG (Flat)	24	18"	2735341	126
ACG (Striated)	24	18"	2735441	126
ACG (Pencil Ribs)	24	18"	2785241	126
PVDF Standard*(Flat)	24	18"	28353__	126
PVDF Standard*(Striated)	24	18"	28354__	126
PVDF Standard*(Pencil Ribs)	24	18"	28852__	126
ACG (Flat)	22	18"	2935341	156
ACG (Striated)	22	18"	2935441	156
ACG (Pencil Ribs)	22	18"	2985241	156
PVDF* (Flat)	22	18"	30353__	156
PVDF* (Striated)	22	18"	30354__	156
PVDF* (Pencil Ribs)	22	18"	30852__	156

PANEL NOTES

- For panel lengths over 45'-0", please inquire.
- Minimum recommended roof slope: 1/2:12.
- All panels have factory applied sealant.
- Oil canning is not a cause for rejection. Heavier gauges help minimize oil canning.
- The Magna-Loc panel system requires the use of a mechanical seamer for proper installation. Contact Metal Sales for rental information.
- If requested, panels are factory notched and/or pre-punched for endlap conditions.
- Finish: PVDF (Meets Kynar 500/Hylar 5000 Specs).
- For additional information on product applications, loadings and flashing details, consult the Product or Installation Manuals.

- __ Represents color code designation.
- See page 6 in this manual or Metal Sales color guides for color selection.
- Requires additional lead time.

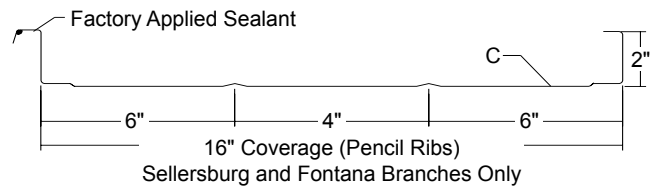
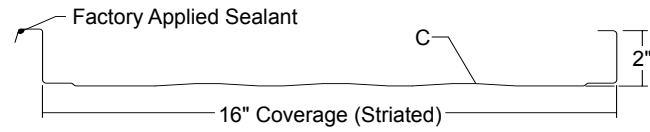
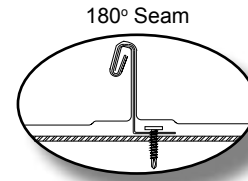
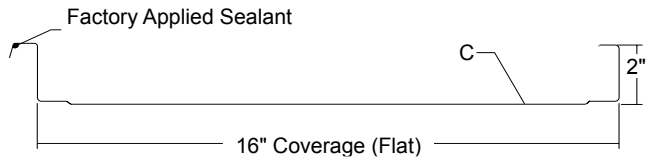

FINISH	GAUGE	COVERAGE	PRODUCT NO.	WT/SQ
ACG (Flat)	24	16"	2735741	130
ACG (Striated)	24	16"	2735841	130
ACG (Pencil Rib)	24	16"	2735541	130
PVDF Standard•(Flat)	24	16"	28357__	130
PVDF Standard•(Striated)	24	16"	28358__	130
PVDF Standard•(Pencil Rib)	24	16"	28355__	130
ACG (Flat)	22	16"	2935741	161
ACG (Striated)	22	16"	2935841	161
ACG (Pencil Rib)	22	16"	2935541	161
PVDF• (Flat)	22	16"	30357__	161
PVDF• (Striated)	22	16"	30358__	161
PVDF• (Pencil Rib)	22	16"	30355__	161
ACG (Flat)	24	18"	2735941	126
ACG (Striated)	24	18"	2736041	126
ACG (Pencil Rib)	24	18"	2735641	126
PVDF Standard•(Flat)	24	18"	28359__	126
PVDF Standard•(Striated)	24	18"	28360__	126
PVDF Standard•(Pencil Rib)	24	18"	28356__	126
ACG (Flat)	22	18"	2935941	156
ACG (Striated)	22	18"	2936041	156
ACG (Pencil Rib)	22	18"	2935641	156
PVDF• (Flat)	22	18"	30359__	156
PVDF• (Striated)	22	18"	30360__	156
PVDF• (Pencil Rib)	22	18"	30356__	156

PANEL NOTES

- For panel lengths over 45'-0", please inquire.
- Minimum recommended roof slope: 1/2:12.
- All panels have factory applied sealant.
- Oil canning is not a cause for rejection. Heavier gauges help minimize oil canning.
- The Magna-Loc panel system requires the use of a mechanical seamer for proper installation. Contact Metal Sales for rental information.
- If requested, panels are factory notched and/or pre-punched for endlap conditions.
- Finish: PVDF (Meets Kynar 500/Hylar 5000 Specs).
- For additional information on product applications, loadings and flashing details, consult the Product or Installation Manuals.

-- Represents color code designation.

• See page 6 in this manual or Metal Sales color guides for color selection.

• Requires additional lead time.

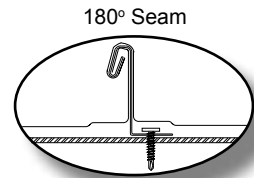
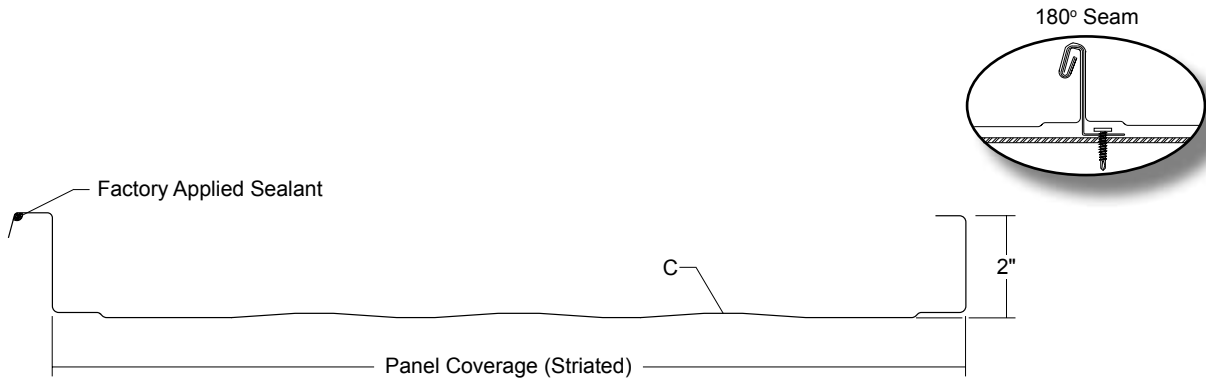

FINISH	GAUGE	COVERAGE	PRODUCT NO.	WT/SQ
ACG (Striated)	24	16"	3135841	130
PVDF Standard*(Striated)	24	16"	32358__	130
ACG (Striated)	24	16"	3335841	161
PVDF* (Striated)	22	16"	34358__	161
ACG (Striated)	24	18"	3536041	126
PVDF Standard*(Striated)	24	18"	37360__	126
ACG (Striated)	22	18"	3836041	156
PVDF* (Striated)	22	18"	39360__	156

PANEL NOTES

- For panel lengths over 45'-0", please inquire.
- Minimum recommended roof slope: 1/2:12.
- All panels have factory applied sealant. The sealant is applied as part of the curving operation.
- Oil canning is not a cause for rejection. Heavier gauges help minimize oil canning.
- The Magna-Loc panel system requires the use of a mechanical seamer for proper installation. Contact Metal Sales for rental information.
- If requested, panels are factory notched and/or pre-punched for endlap conditions.
- Finish: PVDF (Meets Kynar 500/Hylar 5000 Specs).
- For additional information on product applications, loadings and flashing details, consult the Product or Installation Manuals.
- Add 30 feet of extra sheets for fine tuning curving machine per radius, per job.

__ Represents color code designation.





◆ See page 6 in this manual or Metal Sales color guides for color selection.

• Requires additional lead time.

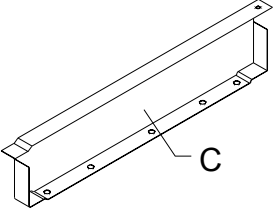
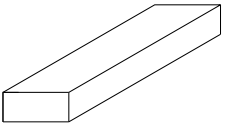
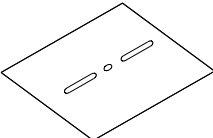
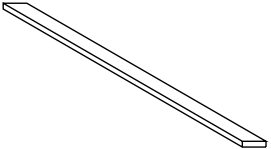
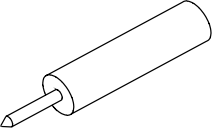
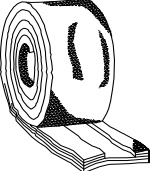
* Additional charges for Field Bending and for Factory Bending

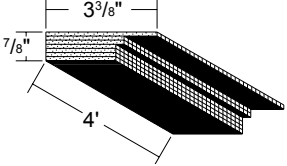
MAGNA-LOC CLIP (FLOATING)	SIZE	TYPE	PRODUCT NO.	CARTON QUANTITY	WT/ CARTON
	2 ³ / ₈ "	Low (Floating)	4923302	50 pieces	12.50 lbs
	3 ³ / ₈ "	High (Floating)	4923303	50 pieces	15.50 lbs
MAGNA-LOC CLIP (FIXED)	SIZE	TYPE	PRODUCT NO.	CARTON QUANTITY	WT/ CARTON
	*2 ¹ / ₈ "	Utility (Fixed)	4923321	50 pieces	6.00 lbs
	2 ³ / ₈ "	Low (Fixed)	4923322	50 pieces	7.00 lbs
*Pancake Head fasteners to be used with fixed clips.					
MAGNA-LOC RAKE ZEE	SIZE	FINISH	TYPE	PRODUCT NO.	WT
	2" x 16 Ga.	Galvanized	Utility 10'-0"	4923850	9.80 lbs
	2 ³ / ₈ " x 16 Ga.	Galvanized	Low 10'-0"	4923855	10.60 lbs
	3 ³ / ₈ " x 16 Ga.	Galvanized	High 10'-0"	4923865	12.80 lbs
MAGNA-LOC RAKE ZEE (CURVED APPLICATION)	SIZE	FINISH	TYPE	PRODUCT NO.	WT
	2" x 16 Ga.	Galvanized	Utility 10'-0"	4924850	9.80 lbs
	2 ³ / ₈ " x 16 Ga.	Galvanized	Low 10'-0"	4924855	10.60 lbs
	3 ³ / ₈ " x 16 Ga.	Galvanized	High 10'-0"	4924865	12.80 lbs
BACK-UP CHANNEL	SIZE	FINISH	LENGTH	PRODUCT NO.	WT
	3" x 3/8"	Galvanized	48"	4923640	2.00 lbs
	3" x 3/8"	Galvanized	72"	4923645	4.00 lbs
MAGNA-LOC EAVE PLATE	SIZE	FINISH	TYPE	PRODUCT NO.	WT
	3/8" x 16 Ga.	Galvanized	Low 10'-0"	4923835	7.80 lbs
	1 ³ / ₈ " x 16 Ga.	Galvanized	High 10'-0"	4923845	10.30 lbs
MAGNA-LOC EAVE PLATE (CURVED APPLICATION)	SIZE	FINISH	TYPE	PRODUCT NO.	WT
	3/8" x 16 Ga.	Galvanized	Low 10'-0"	4933800	7.80 lbs
	1 ³ / ₈ " x 16 Ga.	Galvanized	High 10'-0"	4934800	10.30 lbs
MAGNA-LOC END DAM (LEFT TO RIGHT)	SIZE	FINISH	PRODUCT NO.	WT	
	16" x 24 Ga.	Galvanized	4925010	.60 lbs	
	16" x 24 Ga.	Painted	49255__	.60 lbs	
	18" x 24 Ga.	Galvanized	4925020	.80 lbs	
	18" x 24 Ga.	Painted	49256__	.80 lbs	

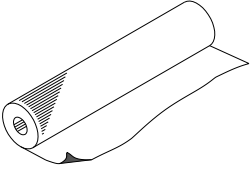
MAGNA-LOC END DAM (RIGHT TO LEFT) 	SIZE	FINISH	PRODUCT NO.		WT
	16" x 24 Ga.	Painted	49257__		.60 lbs
	18" x 24 Ga.	Painted	49258__		.80 lbs
THERMAL BLOCK 	SIZE	FINISH	PRODUCT NO.		WT/100
	3/8" x 3" x 16"	Polystyrene Foam	4923787		1.50 lbs
	3/8" x 3" x 18"	Polystyrene Foam	4923775		1.75 lbs
	1" x 3" x 16"	Polystyrene Foam	4923760		3.00 lbs
	1" x 3" x 18"	Polystyrene Foam	4923770		3.50 lbs
BEARING PLATE 	SIZE	FINISH	PRODUCT NO.		WT/100
	4" x 5" x 20 Ga.	Galvanized	4923886		30 lbs
ENDLAP PAD 	PANEL	SIZE	PRODUCT NO.	TYPE	WT/CARTON
	Seam-Loc 24 Magna-Loc Snap-Loc 24	1 1/2" x 3/32" x 27"	6411998	Butyl	27 lbs
	Note: 51 pieces per box				
TUBE SEALANT 	SIZE	COLOR	PRODUCT NO.	CARTON QUANTITY	WT/ CARTON
	10.3 oz	Urethane White	6402830	30 cartridges	19.31 lbs
	10.3 oz	Urethane Bronze	6402999	30 cartridges	19.31 lbs
	10.3 oz	Urethane Gray	6402829	30 cartridges	19.31 lbs
	10.3 oz	Acrylic Clear	6402800	30 cartidges	19.31 lbs
TAPE SEALANT  Double Bead	SIZE	TYPE	PRODUCT NO.	CARTON QUANTITY	WT/ CARTON
	7/8" x 3/16" x 25'	Butyl (Double Bead)	6403899	20 rolls	40.00 lbs

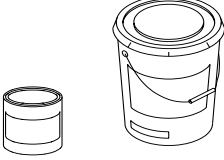
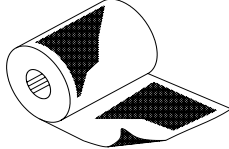
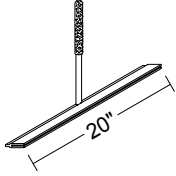
<p>VENT MATERIAL</p> 	<p>SIZE</p> <p>3⁵/₁₆" x 7/8" x 4'</p>	<p>TYPE</p> <p>Black</p>	<p>PRODUCT NO.</p> <p>6852406</p>	<p>CARTON QUANTITY</p> <p>24 pieces</p>	<p>WT/ CARTON</p> <p>30.00 lbs</p>	
<p>For use on roof with a 3:12 or greater slope</p>						
<p>TOUCH-UP PAINT</p> 	<p>TYPE</p> <p>For CF45 finish For PVDF finish</p>	<p>SIZE</p> <p>Pint Pint</p>	<p>PRODUCT NO.</p> <p>66004__ 66010__</p>	<p>WT</p> <p>1.60 lbs 1.60 lbs</p>		
<p>__ Represents color code designation</p>						
<p>ms-HT UNDERLAYMENT</p> 	<p>TYPE</p> <p>Peel-and-Stick</p>	<p>SIZE</p> <p>36" x 66.67' (2 Sq Roll)</p>	<p>PRODUCT NO.</p> <p>4121200</p>	<p>WT/ ROLL</p> <p>44.00 lbs</p>		
<p>UNDERLAYMENT PRIMER</p> 			<p>SIZE</p> <p>5 Gallon*</p>	<p>PRODUCT NO.</p> <p>6600000</p>	<p>WT/ ROLL</p> <p>42.00 lbs</p>	
<p>*100-125 ft² per gallon depending on substrate.</p>						
<p>ALSAN</p> 	<p>TYPE</p> <p>Kit*</p>	<p>SIZE</p> <p>5 Gallon* 1 Gallon* 5 Gallon</p>	<p>PRODUCT NO.</p> <p>4130200 4130300 4130100</p>	<p>WT</p> <p>47.00 lbs 10.00 lbs 9.20 lbs</p>		
<p>*50 lf per gallon depending on weather tempature Kit includes 1 gallon Alsan, tools, instnctional video, and roll of Poly Fleece</p>						
<p>POLY FLEECE ROLL</p> 	<p>SIZE</p> <p>4" x 50' 6" x 50'</p>	<p>TYPE</p> <p>Poly Fleece Poly Fleece</p>	<p>PRODUCT NO.</p> <p>4130500 4130400</p>	<p>QUANTITY</p> <p>1 rolls 1 rolls</p>	<p>WT</p> <p>.30 lbs .50 lbs</p>	
<p>HEMMING TOOL</p> 	<p>TYPE</p> <p>Zinc Plated</p>	<p>SIZE</p> <p>20"</p>	<p>PRODUCT NO.</p> <p>6560102</p>	<p>WT/100</p> <p>4.00 lbs</p>		
<p>Used for bending lower end of the metal panel to accept Offset Cleat flashing for concealed fastener application.</p>						

RUBBER ROOF DECK FLASHINGS

TYPE	SIZE	BASE DIAM.	PRODUCT NO.	WT
Rubber	#1 Flasher	1/4" - 2"	68501__*	3.00 lbs
Rubber	#2 Flasher	1 3/4" - 3 1/4"	68502__*	3.00 lbs
Rubber	#3 Flasher	1/4" - 5"	68503__*	3.00 lbs
Rubber	#4 Flasher	3" - 6 1/4"	68504__*	3.00 lbs
Rubber	#5 Flasher	4 1/4" - 7 1/2"	68505__*	5.00 lbs
Rubber	#6 Flasher	5" - 9"	68506__*	9.00 lbs
Rubber	#7 Flasher	6" - 11"	68507__*	11.00 lbs
Rubber	#8 Flasher	7" - 13"	68508__*	13.00 lbs
Rubber	#9 Flasher	10" - 19"	68509__*	13.00 lbs

*Special order colors: 93=Brown; 94=Green; 95=Red; 96=Blue; 97=White; 98=Grey; 99=Black

ROUND

Rubber Roof Jack Round Base

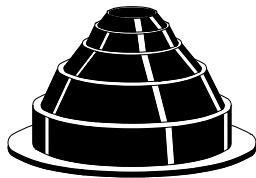

HT Silicone	#1 Flasher	1/4" - 2"	6850011	3.00 lbs
HT Silicone	#2 Flasher	1 3/4" - 3 1/4"	6850012	3.00 lbs
HT Silicone	#3 Flasher	1/4" - 5"	6850013	3.00 lbs
HT Silicone	#4 Flasher	3" - 6 1/4"	6850014	3.00 lbs
HT Silicone	#5 Flasher	4 1/4" - 7 1/2"	6850015	5.00 lbs
HT Silicone	#6 Flasher	5" - 9"	6850016	9.00 lbs
HT Silicone	#7 Flasher	6" - 11"	6850017	11.00 lbs
HT Silicone	#8 Flasher	7" - 13"	6850018	13.00 lbs
HT Silicone	#9 Flasher	10" - 19"	6850019	13.00 lbs
Retrofit HT	#1 Masterflash	1/4" - 2"	6850060	4.00 lbs
Retrofit HT	#2 Masterflash	1 1/4" - 3"	6850061	4.00 lbs
Retrofit HT	#3 Masterflash	1 1/4" - 4"	6850062	4.00 lbs

GRAY ROUND RETRO ROOF JACK

Retrofit E.P.D.M.	#1 Masterflash	1/4" - 2"	6850070	4.00 lbs
Retrofit E.P.D.M.	#2 Masterflash	1 1/4" - 3"	6850071	4.00 lbs
Retrofit E.P.D.M.	#3 Masterflash	1/4" - 4"	6850072	4.00 lbs

BLACK ROUND RETRO ROOF JACK

Retrofit E.P.D.M.	#1 Masterflash	1/4" - 2"	6850073	4.00 lbs
Retrofit E.P.D.M.	#2 Masterflash	1 1/4" - 3"	6850074	4.00 lbs
Retrofit E.P.D.M.	#3 Masterflash	1/4" - 4"	6850075	4.00 lbs

SQUARE

Retro Roof Jack Square Base

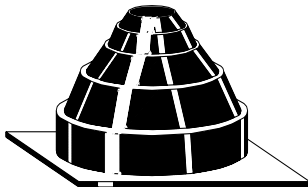

BLACK SQUARE RETRO ROOF JACK

Retrofit E.P.D.M.	#1 Masterflash	1/4" - 2"	6850046	4.00 lbs
Retrofit E.P.D.M.	#2 Masterflash	1 1/4" - 3"	6850047	4.00 lbs
Retrofit E.P.D.M.	#3 Masterflash	1/4" - 4"	6850048	4.00 lbs

*Kit includes: membrane fasteners, termination strips, splice material and sealant. (Deck Flashing temperature range is -65° to +250°: HT Deck Flashing temperature range is -100° to +450°)

MAGNA-LOC FLASHING PROFILES

VENTED RIDGE COVER	GAUGE	FINISH	PRODUCT NO.	WT	LENGTH									
	24	ACG	5701341	13.40 lbs	10'-2"									
	24	ACG	5701541	26.80 lbs	20'-3"									
	24	PVDF	58013__	13.40 lbs	10'-2"									
	24	PVDF	58015__	26.80 lbs	20'-3"									
* See chart on page 7														
VENT DRIP	GAUGE	FINISH	PRODUCT NO.	WT	LENGTH									
	24	ACG	5701741	3.30 lbs	10'-2"									
	24	PVDF	58017__	3.30 lbs	10'-2"									
SSR RIDGE	GAUGE	FINISH	PRODUCT NO.	WT	LENGTH									
	24	ACG	5775141	15.20 lbs	10'-2"									
	24	ACG	5775341	30.40 lbs	20'-3"									
	24	PVDF	58751__	15.20 lbs	10'-2"									
	24	PVDF	58753__	30.40 lbs	20'-3"									
* See chart on page 7														
20" HIP COVER	GAUGE	FINISH	PRODUCT NO.	WT	LENGTH									
	24	ACG	5700641	15.90 lbs	10'-2"									
	24	ACG	5700841	31.80 lbs	20'-3"									
	24	PVDF	58006__	15.90 lbs	10'-2"									
	24	PVDF	58008__	31.80 lbs	20'-3"									
* See chart on page 7														
EXPANSION JOINT	GAUGE	FINISH	PRODUCT NO.	WT	LENGTH									
	24	ACG	6372241	10.60 lbs	10'-2"									
	24	ACG	6372341	21.20 lbs	20'-3"									
	24	PVDF	64722__	10.60 lbs	10'-2"									
	24	PVDF	64723__	21.20 lbs	20'-3"									
VALLEY	GAUGE	FINISH	PRODUCT NO.	WT	LENGTH									
	24	ACG	5701841	16.85 lbs	10'-2"									
	24	ACG	5702041	33.70 lbs	20'-3"									
	24	PVDF	58018__	16.85 lbs	10'-2"									
	24	PVDF	58020__	33.70 lbs	20'-3"									
* See chart on page 7														
MAGNA-LOC SRR 4.5" DROP VALLEY	GAUGE	FINISH	PRODUCT NO.	WT	LENGTH									
<table border="1" style="margin-top: 10px;"> <thead> <tr> <th>SYSTEM</th> <th>A</th> <th>B</th> </tr> </thead> <tbody> <tr> <td>LOW</td> <td>3/8"</td> <td>4 1/2"</td> </tr> <tr> <td>HIGH</td> <td>1 3/8"</td> <td>3 1/2"</td> </tr> </tbody> </table>	SYSTEM	A	B	LOW	3/8"	4 1/2"	HIGH	1 3/8"	3 1/2"	Low 4.5" Drop Valley				
	SYSTEM	A	B											
	LOW	3/8"	4 1/2"											
	HIGH	1 3/8"	3 1/2"											
	24	ACG	5781741	18.20 lbs	10'-2"									
	24	ACG	5781941	36.40 lbs	20'-3"									
	24	PVDF	58817__	18.20 lbs	10'-2"									
	24	PVDF	58819__	36.40 lbs	20'-3"									
	High 4.5" Drop Valley													
	24	ACG	5782341	18.20 lbs	10'-2"									
	24	ACG	5782541	36.40 lbs	20'-3"									
	24	PVDF	58823__	18.20 lbs	10'-2"									
24	PVDF	58825__	36.40 lbs	20'-3"										
* See chart on page 7														

MAGNA-LOC SSR 9" DROP VALLEY

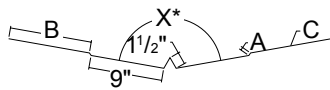

SYSTEM	A	B
LOW	3/8"	10"
HIGH	1 3/8"	9"

GAUGE	FINISH	PRODUCT NO.	WT	LENGTH
Low 9" Drop Valley				
24	ACG	5786341	35.60 lbs	10'-2"
24	ACG	5786441	70.80 lbs	20'-3"
24	PVDF	58863__	35.60 lbs	10'-2"
24	PVDF	58864__	70.80 lbs	20'-3"
High 9" Drop Valley				
24	ACG	5786741	35.60 lbs	10'-2"
24	ACG	5786841	70.80 lbs	20'-3"
24	PVDF	58867__	35.60 lbs	10'-2"
24	PVDF	58868__	70.80 lbs	20'-3"

* See chart on page 7

PEAK

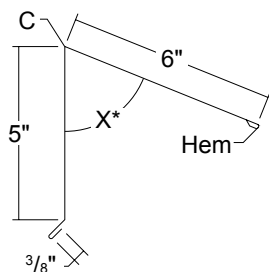

GAUGE	FINISH	PRODUCT NO.	WT	LENGTH
24	ACG	5702241	9.95 lbs	10'-2"
24	ACG	5702441	19.90 lbs	20'-3"
24	PVDF	58022__	9.95 lbs	10'-2"
24	PVDF	58024__	19.90 lbs	20'-3"

* See chart on page 7

SSR SCULPTURED HIGH SIDE EAVE

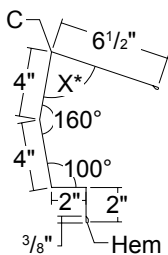

GAUGE	FINISH	PRODUCT NO.	WT	LENGTH
24	ACG	5776941	16.75 lbs	10'-2"
24	ACG	5777141	33.50 lbs	20'-3"
24	PVDF	58769__	16.75 lbs	10'-2"
24	PVDF	58771__	33.50 lbs	20'-3"

* See chart on page 7

EAVE

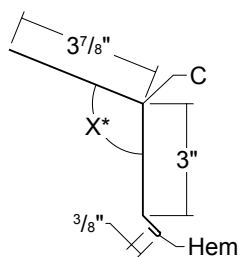

GAUGE	FINISH	PRODUCT NO.	WT	LENGTH
24	ACG	5706541	6.35 lbs	10'-2"
24	PVDF	58065__	6.35 lbs	10'-2"

* See chart on page 7

EXTENDED EAVE

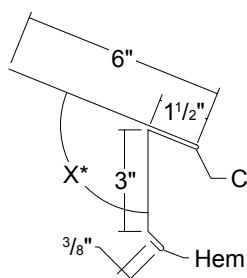

GAUGE	FINISH	PRODUCT NO.	WT	LENGTH
24	ACG	5707341	9.55 lbs	10'-2"
24	PVDF	58073__	9.55 lbs	10'-2"

* See chart on page 7



	GAUGE	FINISH	PRODUCT NO.	WT	LENGTH	
	24	ACG	5783541	11.50 lbs	10'-2"	
	24	ACG	5783741	23.00 lbs	20'-3"	
	24	PVDF	58835__	11.50 lbs	10'-2"	
	24	PVDF	58837__	23.00 lbs	20'-3"	
	* See chart on page 7					
	24	ACG	5703441	9.95 lbs	10'-2"	
	24	ACG	5703641	19.90 lbs	20'-3"	
	24	PVDF	58034__	9.95 lbs	10'-2"	
	24	PVDF	58036__	19.90 lbs	20'-3"	
	24	ACG	5776741	2.00 lbs	10'-2"	
	24	PVDF	58767__	2.00 lbs	10'-2"	
	24	ACG	5776541	2.60 lbs	10'-2"	
	24	PVDF	58765__	2.60 lbs	10'-2"	
	24	ACG	5775941	16.75 lbs	10'-2"	
	24	ACG	5776141	33.50 lbs	20'-3"	
	24	PVDF	58759__	16.75 lbs	10'-2"	
	24	PVDF	58761__	33.50 lbs	20'-3"	
	24	ACG	5776341	.18 lbs		
	24	PVDF	58763__	.18 lbs		

	GAUGE	FINISH	PRODUCT NO.	WT	LENGTH
	24	ACG	5777741	8.80 lbs	10'-2"
	24	PVDF	58777__	8.80 lbs	10'-2"
	24	ACG	5777341	10.80 lbs	10'-2"
	24	ACG	5777541	21.60 lbs	20'-3"
	24	PVDF	58773__	10.80 lbs	10'-2"
	24	PVDF	58775__	21.60 lbs	20'-3"
* See chart on page 7					
	24	ACG	5705241	3.35 lbs	10'-2"
	24	PVDF	58052__	3.35 lbs	10'-2"
	24	ACG	5705441	3.20 lbs	10'-2"
	24	PVDF	58054__	3.20 lbs	10'-2"
	24	ACG	5707741	16.95 lbs	10'-2"
	24	ACG	5707941	33.90 lbs	20'-3"
	24	PVDF	58077__	16.95 lbs	10'-2"
	24	PVDF	58079__	33.90 lbs	20'-3"
* See chart on page 7					
	24	ACG	5780841	18.90 lbs	10'-2"
	24	ACG	5781041	37.80 lbs	20'-3"
	24	PVDF	58808__	18.90 lbs	10'-2"
	24	PVDF	58810__	37.80 lbs	20'-3"
* See chart on page 7					

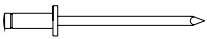
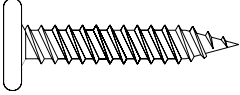
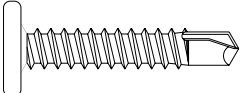
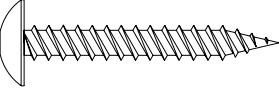

BOX GUTTER END	GAUGE	FINISH	PRODUCT NO.	WT	
	24	ACG	5708141 (Left) 5708241 (Right)	.24 lbs	
	24	PVDF	58081__ (Left) 58082__ (Right)	.24 lbs	
SCULPTURED GUTTER END	GAUGE	FINISH	PRODUCT NO.	WT	
	24	ACG	5781241 (Left) 5781341 (Right)	.24 lbs	
	24	PVDF	58812__ (Left) 58813__ (Right)	.24 lbs	
SSR GUTTER DRIP	GAUGE	FINISH	PRODUCT NO.	WT	LENGTH
	24	ACG	5778141	8.70 lbs	10'-2"
	24	PVDF	58781__	8.70 lbs	10'-2"
* See chart on page 7					
SSR GUTTER SUPPORT	GAUGE	FINISH	PRODUCT NO.	WT	LENGTH
	24	ACG	5781441	.25 lbs	0'-10"
	24	PVDF	58814__	.25 lbs	0'-10"
UNIVERSAL GUTTER/ DOWNSPOUT STRAP	GAUGE	FINISH	PRODUCT NO.	WT	LENGTH
	24	ACG	5709241	.36 lbs	1'-4"
	24	PVDF	58092__	.36 lbs	1'-4"
4" x 6" DOWNSPOUT	GAUGE	FINISH	PRODUCT NO.	WT	LENGTH
	24	ACG	5709841	16.95 lbs	10'-2"
	24	ACG	5710141	33.90 lbs	20'-3"
	24	PVDF	58098__	16.95 lbs	10'-2"
	24	PVDF	58101__	33.90 lbs	20'-3"
3 1/2" x 4" DOWNSPOUT	GAUGE	FINISH	PRODUCT NO.	WT	LENGTH
	24	ACG	5709441	12.90 lbs	10'-2"
	24	ACG	5709741	25.80 lbs	20'-3"
	24	PVDF	58094__	12.90 lbs	10'-2"
	24	PVDF	58097__	25.80 lbs	20'-3"

4" DOWNSPOUT BRACKET		GAUGE	FINISH	PRODUCT NO.	WT	
		24	ACG	5711041	.12 lbs	
		24	PVDF	58110__	.12 lbs	
6" DOWNSPOUT BRACKET		GAUGE	FINISH	PRODUCT NO.	WT	
		24	ACG	5711241	.15 lbs	
		24	PVDF	58112__	.15 lbs	
ELBOWS		GAUGE	FINISH	PRODUCT NO.	WT	
<p>TYPE A ELBOWS</p> <p>TYPE B ELBOW</p>		3 1/2" x 4" ELBOWS (D x W)				
		95 DEGREE	ACG	5710241	2.30 lbs	
		24				
		24	PVDF	58102__	2.30 lbs	
		45 DEGREE	ACG	5710641	2.30 lbs	
		24				
		24	PVDF	58106__	2.30 lbs	
		4" x 6" ELBOWS (D x W)				
		95 DEGREE	ACG	5710441	3.00 lbs	
		24				
24	PVDF	58104__	3.00 lbs			
45 DEGREE	ACG	5710841	3.00 lbs			
24						
24	PVDF	58108__	3.00 lbs			
<p>Notes:</p> <p>1) Type "A" & "B" has seam on heel. Specify otherwise at time of order.</p> <p>2) Specify left or right at time of order for Type "B" elbows.</p>						
OFFSET CLEAT		GAUGE	FINISH	PRODUCT NO.	WT	LENGTH
		24	Supplied in Various Colors	5806499	2.40 lbs	10'-2"

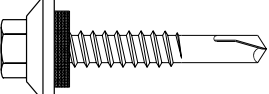
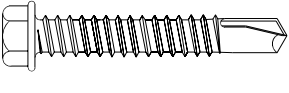
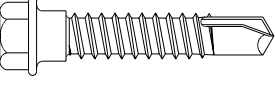
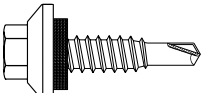
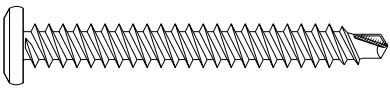

	GAUGE	FINISH	PRODUCT NO.	WT	LENGTH
MAGNA-LOC CLEAT 	24	Supplied in Various Colors	5806099	2.40 lbs	10'-2"
	MAGNA-LOC Z-CLOSURE 				
	24	ACG	5782641	3.32 lbs	10'-2"
	24	PVDF	58826__	3.32 lbs	10'-2"
MAGNA-LOC RIB COVER 	24	ACG	5785441	.57 lbs	8"
	24	PVDF	58854__	.57 lbs	8"
<p>Sold as a 2-piece unit.</p>					
SSR SCULPTURED GUTTER CORNER BOX <p>Looking from Eave to Ridge (Right Shown)</p>	24	ACG	5778441	6.00 lbs	
	24	PVDF	58784__	6.00 lbs	
<p>Specify Roof Slope Specify Right or Left</p>					
SSR SCULPTURED PEAK BOX 	24	ACG	5778541	6.00 lbs	
	24	PVDF	58785__	6.00 lbs	
<p>* See chart on page 7 Specify Roof Slope</p>					

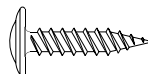
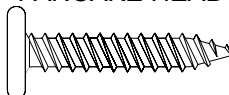
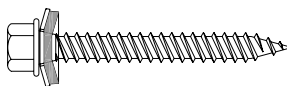
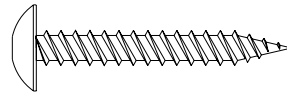
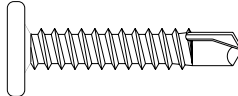

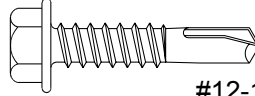
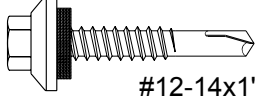
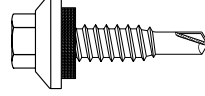
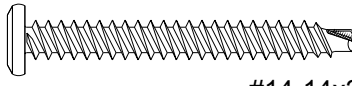
POP RIVET 	SIZE	TYPE	FINISH	APPLICATION
	1/8"X 3/16"	A	Unpainted	Flashing to Panel or Flashing
	1/8"X 3/16"	A	Painted	Flashing to Panel or Flashing
PANCAKE HEAD WOODSCREW 	SIZE	TYPE	FINISH	APPLICATION
	#10-12x1"	A	Plated	Flashing to wood decking
PANCAKE HEAD DRILLER 	SIZE	TYPE	FINISH	APPLICATION
	#10-16x1"	Driller	Plated	Flashing to metal substructure
LOW PROFILE WOODSCREW 	SIZE	TYPE	FINISH	APPLICATION
	#12-11x1 1/2"	A	Plated	Clips to wood decking
WOODSCREW XL 	SIZE	TYPE	FINISH	APPLICATION
	#9-16x1 1/4"-1 1/2"	A	Unpainted	Panel or Flashing to wood substructure
	#9-16x1 1/4"-1 1/2"	A	Painted	Panel or Flashing to wood substructure
SELF DRILLER XL 	SIZE	TYPE	FINISH	APPLICATION
	#12-14x1 1/4"-1 1/2"	Driller	Unpainted	Panel or Flashing to metal substructure
	#12-14x1 1/4"-1 1/2"	Driller	Painted	Panel or Flashing to metal substructure
SELF DRILLER NO WASHER 	SIZE	TYPE	FINISH	APPLICATION
	1/4"-14x1 1/2"	Driller (#2 point)	Plated	Panel clipst to metal substructure
	#12-24x1 1/4"	Driller (#4 point)	Plated	Panel clipst to bar joists up to 3/8" thick
	#12-14x1"	Driller	Plated	Accessories to meta substructure and used with framing on retrofit
SHOULDER SELF DRILLER 	SIZE	TYPE	FINISH	APPLICATION
	1/4"-14x1 1/4"	Driller	Plated	For use with Floating Rake Zee to substructure
STITCH SCREW XL 	SIZE	TYPE	FINISH	APPLICATION
	1/4"-14x7/8"	Stitch	Unpainted	Flashing to Panel or Flashing
	1/4"-14x7/8"	Stitch	Painted	Flashing to Panel or Flashing
DECK SCREW 	SIZE	TYPE	FINISH	APPLICATION
	#14-14x2"-8"	Driller	Black	Panel Clip to metal deck and rigid board insulation assembly or wood substructure

PHYSICAL PROPERTIES

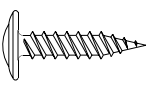
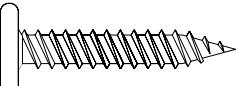
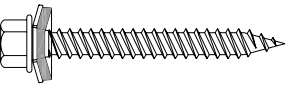
FASTENER	HEAD DIA/TYPE	THREAD DIA. O.D.	THREAD DIA. I.D.	MIN TENSILE	MIN. TORSIONAL	NOM. SHEAR
 <p>TRUSS HEAD WOODSCREW #8-15x³/₄"</p>	Truss Hd. #2 Philips	.162-.168	.105-.110	1672 lbs	61 In lbs	1087 lbs
 <p>PANCAKE HEAD WOODSCREW #10-12x1"</p>	.447 IN. #2 Philips	.188-.194	.126-.133	1673 lbs	79 In lbs	1311 lbs
 <p>WOODSCREW #9-16x1", 1¹/₂"</p>	1/4" HWH	.175-.181	.127-.133	2429 lbs	80 In lbs	1355 lbs
 <p>LOW PROFILE WOODSCREW 12-11 x1¹/₂"</p>	#3 Square Drive	.201-.208	.125-.131	2050 lbs	81 In lbs	1369 lbs
 <p>PANCAKE HEAD DRILLER #10-16x1" SELF DRILLING</p>	#2 Philips	.183-.189	.135-.141	1984 lbs	80 In lbs	1442 lbs
 <p>SELF DRILLER NO WASHER 1/4"-14x1¹/₂" SELF DRILLING</p>	3/8" HWH	.240-.246	.185-.192			
 <p>SELF DRILLER NO WASHER #12-14x1", 1¹/₂" SELF DRILLING</p>	5/16" HWH	.209-.215	.157-.165			
 <p>SELF DRILLER #12-14x1", 1¹/₄", 1¹/₂" SELF DRILLING</p>	5/16" HWH	.209-.215	.157-.165			
 <p>STITCH 1/4"-14x⁷/₈" SELF DRILLING</p>	5/16" HWH	.240-.246	.185-.192			
 <p>DECK SCREW #14-14x2", 4", 5", 6", 8"</p>	#3 Philips .448 Max	.235-.242	.155			

PULL OUT VALUES - POUNDS (RECOMMENDED SAFETY FACTOR)

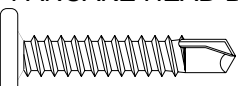
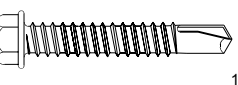
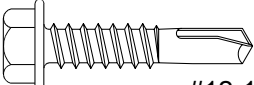
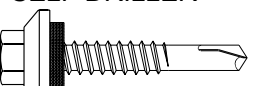
FASTENER	Plywood			OSB		Hard/Soft Wood			
	3/4"	5/8"	1/2"	19/32"	7/16"	Spruce	Fir	Oak	Pine
 TRUSS HEAD WOODSCREW #8-15x3/4"	461	340 (3.26)	377 ()		98	375	405	593	464
 PANCAKE HEAD WOODSCREW #10-12x1"	615	521	339	290	257				
 WOODSCREW #9-16x1", 1 1/2"	565	498	326		223	1537			
 LOW PROFILE WOODSCREW 12-11 x1 1/2"									

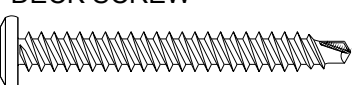
FASTENER	Steel									
	3/8"	1/4"	3/16"	10 GA	12 GA (55)	14 GA (55)	16 GA (55)	18 GA (50)	22 GA (50)	
 PANCAKE HEAD DRILLER #10-16x1" SELF DRILLING					1514 (2.59)	953 (2.54)	825 (2.54)		167 (2.69)	
 SELF DRILLER NO WASHER 1/4"-14x1 1/2" SELF DRILLING					2031 (2.55)	1172 (2.54)	1043 (2.55)	951 (2.62)	209 (2.68)	
 SELF DRILLER NO WASHER #12-14x1", 1 1/2" SELF DRILLING					1788 (2.54)	1056 (2.54)	850 (3.10)	790 (2.60)	180 (2.76)	
 SELF DRILLER #12-14x1", 1 1/4", 1 1/2" SELF DRILLING										
 STITCH 1/4"-14x7/8" SELF DRILLING										
 DECK SCREW #14-14x2", 4", 5", 6", 8"										

PULL OVER STRENGTH VALUES (POUNDS ULTIMATE)

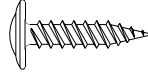
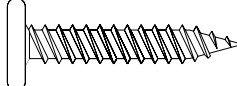
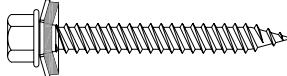
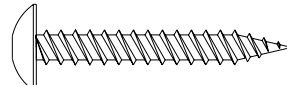
FASTENER	STEEL					
	20 GA	22 GA (50)	24 GA (50)	26 GA (80)	26 GA (50)	29 GA (80)
 TRUSS HEAD WOODSCREW #8-15x ³ / ₄ "		N/A	852 (2.57)	693 (2.64)	619 (2.60)	546 (2.83)
 PANCAKE HEAD WOODSCREW #10-12x1"		1129 (2.56)	843 (2.55)	658 (2.60)	661 (2.55)	500 (3.08)
 WOODSCREW #9-16x1", 1 ¹ / ₂ "		901 (2.59)	728 (2.73)	563 (2.63)	492 (2.67)	426 (2.77)
 LOW PROFILE WOODSCREW 12-11 x1 ¹ / ₂ "						

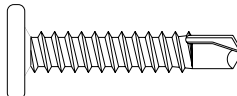
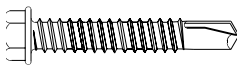
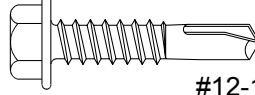
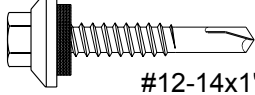
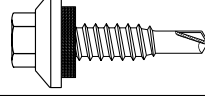
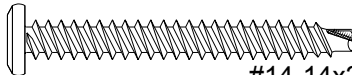
FASTENER	STEEL					
	20 GA	22 GA (50)	24 GA (50)	26 GA (80)	26 GA (50)	29 GA (80)
 PANCAKE HEAD DRILLER #10-16x1" SELF DRILLING			1263 (2.55)	870 (2.63)	654 (2.71)	
 SELF DRILLER NO WASHER 1/4"-14x1 ¹ / ₂ " SELF DRILLING						
 SELF DRILLER NO WASHER #12-14x1", 1 ¹ / ₂ " SELF DRILLING	751 (2.74)		1357 (2.61)	918 (2.60)	667 (2.63)	524 (2.95)
 SELF DRILLER #12-14x1", 1 ¹ / ₄ ", 1 ¹ / ₂ " SELF DRILLING						
 STITCH 1/4"-14x ⁷ / ₈ " SELF DRILLING						
 DECK SCREW #14-14x2", 4", 5", 6", 8"						

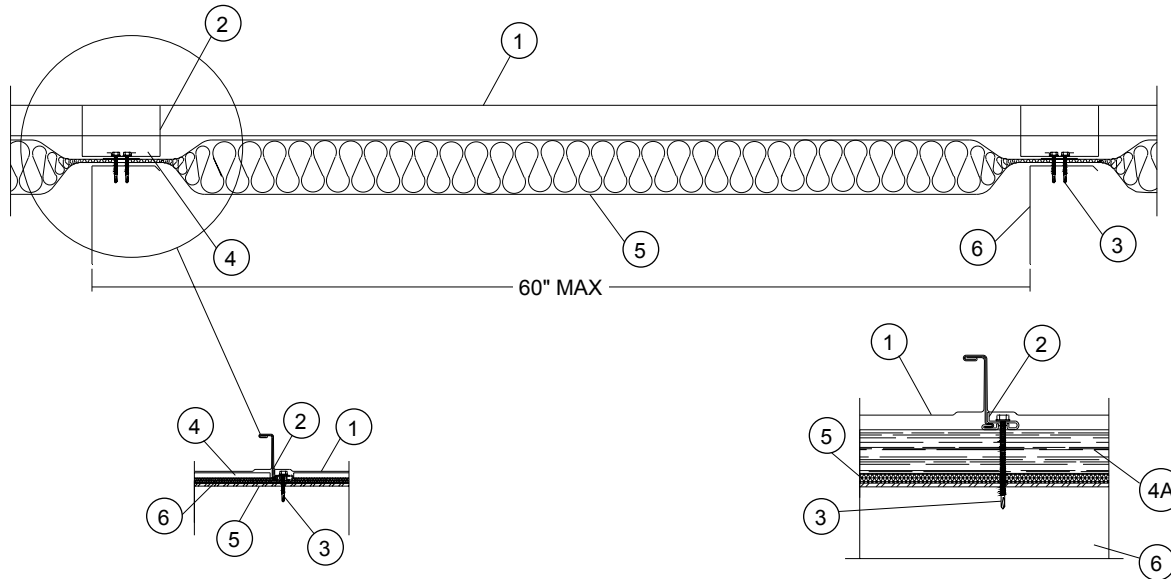

MAGNA-LOC

Construction No. 506
 October 16, 2001
 Uplift - Class 90
 Fire Not Investigated

1. **Metal Roof Deck Panels* No. 24 MSG** min thick coated steel. Panel width, max 18 in., min 12 in.; rib height 2 in. Panels continuous over two or more spans. The panel flat area may have optional striations or minor corrugations placed at various locations in the panel flat area beginning min of 2 in. from side ribs. The upper flange of the panel rib may be horizontal, or optionally formed down to form an angle of 0 degree to 90 degree between the vertical segment and the top flange of the rib. End lap to occur adjacent to and within 12 in. of purlin (Item 6) with panels overlapped 2 in. min. An end lap back-up-plate (Item 2A) to be used. A bead of sealant may be used at panel end laps and side ribs. Ribs to be seamed with an electric or hand seaming tool to form a flange with a tight hem. Seaming process to include the upper portion of the Panel Clips (Item 2).
METAL SALES MFG CORP - "Magna-Loc 18", "Magna-Loc 16"
 2. **Roof Deck Fasteners* (Panel Clips)** Located at side of panels over purlins (Item 6). (**Max spacing 60 in. OC**). When wood thermal block (Item 4A) is used, clips to be located on top. Either of the following:
Fixed Clip (Not Shown) - One piece assembly fabricated from No. 22 MSG min thick steel, 3-1/2 in. wide.
Floating Clip - Two piece assembly with a base fabricated from No. 16 MSG min thick steel, 2 in. wide and a top fabricated from No. 22 MSG min thick steel, 4-5/16 in. wide.
 - 2A. **End Lap Back-Up-Plate** (Not shown) - No. 16 MSG min thick coated steel channel, 3 in. wide with two 3/8 in. deep legs. Max length 74 in. Located under the panel end lap (50 ksi min yield strength).
 - 2B. **Roof Deck Fasteners*(Cinch Plate)** (Optional) - (Not Shown) - width 1-5/16 in., length 18 in. max. Fabricated from No. 20 MSG min thick stainless steel. Located over end lap.
 - 2C. **End Lap Back-Up-Plate** (Optional) - (Not shown) - No. 16 MSG min thick coated steel. Width 11, 13 or 19 in., length 7 in. Two 3/4 in. by 3/4 in. tabs and a 1 in. deep vertical leg located at up-slope edge of panel. Used with Item 2A when Item
- *2B is not used (50 ksi min yield strength).
3. **Fasteners (Screws)** For panel clip-to-purlin attachment to be 1/4"-14 by min 1 in. long self drilling, self-tapping hex-washer-head plated steel screws. **Two fasteners used per clip.** Fasteners used at end lap to be one of the following: No. 1/4-14 by 1 in. long Type AB point, self-drilling, self-tapping hex-washer-head plated or stainless steel screws or No. 12-14 by 1-1/4 in. long self-drilling self-tapping hex-washer-head plated steel screws. Spacing for 16 in. wide panels to be a 1, 3, 4, 4, 3 in. pattern; spacing for 18 in. wide panels to be a 1-1/2, 3-1/2, 4, 4, 3-1/2, 1-1/2 in. pattern. When optional cinch plate (Item 2B) is used, four fasteners to be required, inserted into factory punched guide holes.
 4. **Thermal Spacer** (Optional) - Polyisocyanurate - 3/8 in. min, 2-3/8 in. max thick, 4 in. min width, length sized to fit between panel clips (Item 2).
 5. **Insulation** (Optional) - Any compressible blanket insulation 8 in. max thick before compression, or 6 in. max thick when located between Thermal Spacer (Item 4) or Thermal Block (Item 4A) and purlin (Item 6).
 6. **Purlins** No. 16 MSG min thick steel (50 ksi min yield strength). Max spacing 60 in. OC.
 Refer to General Information, Roof Deck Constructions for items not evaluated.

***Bearing the UL Classification Mark**



Underwriters Laboratories Inc.®
 LISTED

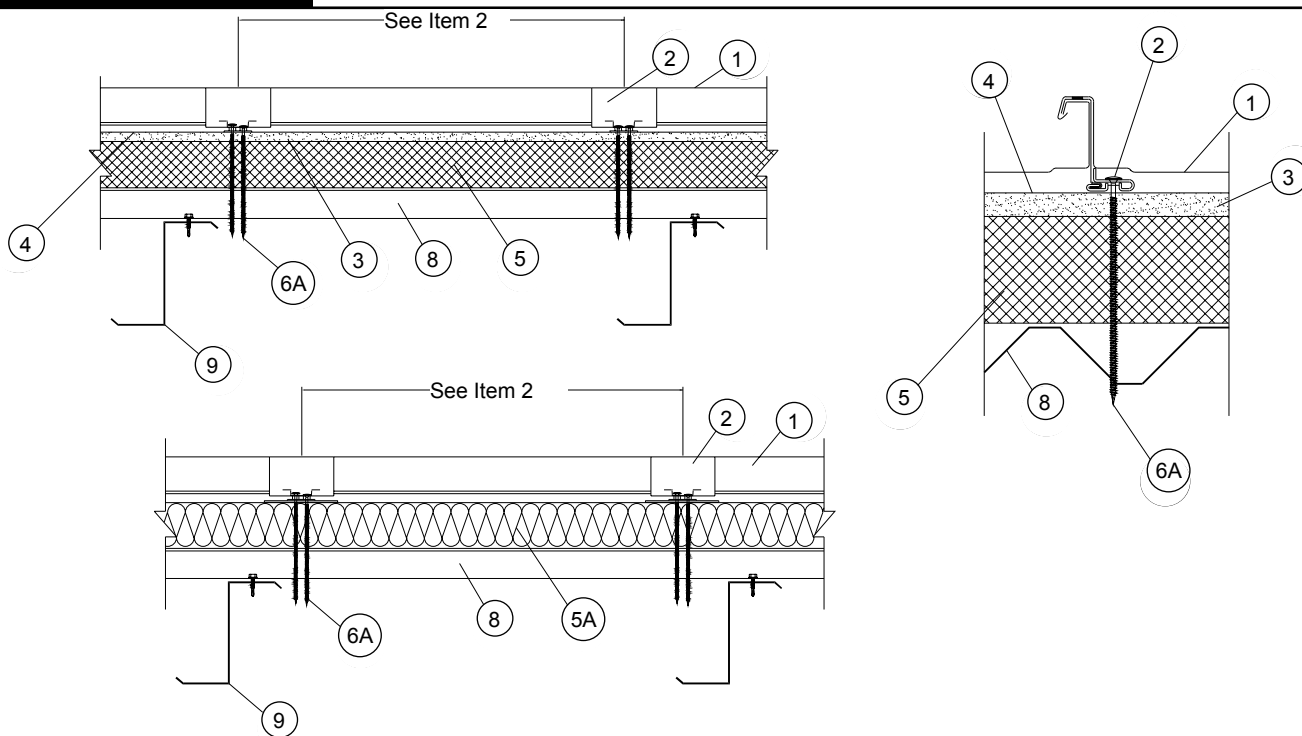

MAGNA-LOC

Construction No. 506A

October 16, 2001

Uplift - Class 90

Fire Not Investigated

1. **Metal Roof Deck Panels*** No. 24 MSG min coated steel. Max panel width 18 in.; min 12 in. Rib height 2 in. Panels continuous over three or more clips (Item 2). The panel flat area may have optional striated or minor ribs placed at various locations in the panel flat area beginning min of 2 in. from side ribs. The upper flange of the panel rib may be horizontal, or optionally formed down to produce an angle of 0 to 90° between the vertical segment and the top flange of the rib. Panel end lap 2 in. min. An end lap back-up plate (Item 2A) to be used at panel end lap. A bead of sealant may be used at panel end lap and side ribs. Ribs to be seamed with an electric or hand seaming tool to form a flange with a tight hem. Seaming process to include the upper portion of the panel clips (Item 2).
METAL SALES MFG CORP - "Magna-Loc 16", "Magna-Loc 18"
2. **Roof Deck Fasteners*** - (Panel Clips) Located at side of panels (Item 1) over substructure (Item 3, 3A, 3B or 3C) and fastened through substructure to liner panel (Item 8) with max spacing of 48 in. OC or over sub-purlins (Item 7) with max spacing of 48 in. OC; or when panel clips are fastened directly to plywood (Item 3B) as described in Item 6B, max spacing to be 36 in. OC.
Fixed Clip (Not Shown) - One piece assembly fabricated from No. 22 MSG min thick steel, 3-1/2 in. wide.
Floating Clip Two piece assembly with a base fabricated from No. 16 MSG min thick steel, 2 in. wide and a tab fabricated from No. 22 MSG min thick steel, 4-1/4 in. wide.
- 2A. **End Lap Back-Up Plate (Not Shown)** - No. 16 MSG min thick coated steel channel, 3 in. wide with two 3/8 in. deep legs. Max length 74 in. Located under the panel (Item 1) end lap (50 ksi min yeild strength).
- 2B. **End Lap Back-Up-Plate (Optional) (Not Shown)** - No. 16 MSG min thick coated steel. Width 11, 13 or 19 in., length 7 in. Two 3/4 in. by 3/4 in. tabs and a 1 in. deep vertical leg located at up-slope edge of panel (50 ksi min yield strength).
- 2C. **Roof Deck Fasteners*(Cinch Plate)**-(Optional)-(Not Shown) width 1-15/16 in., length 18 in. max. Fabricated from No. 20 MSG min thick stainless steel. Located over end lap.
3. **Substructure - (Gypsum Board)** (Optional) - Min thick 1/2 in. To be placed on top of either the liner panel (Item 8) or rigid insulation (Item 5). Combined thickness of the gypsum board and rigid insulation not to exceed 4 in. All joints to be taped with 2.5 in. wide joint tape.
- 3A. **Substructure - (Plywood)** (Optional) - (Not Shown) - Plywood decking, used in lieu of gypsum board (Item 3), to be nom 1/2 in. thick, exposure 1 sheathing, 40/20, CD. Located over rigid insulation (Item 5). Combined thickness of the plywood and rigid insulation not to exceed 4 in.
- 3B. **Substructure - (OSB)** (Optional) - (Not Shown) - OSB decking, used in lieu of gypsum board (Item 3), to be nom 1/2 in. thick. Located over rigid insulation (Item 5). Combined thickness of the OSB and rigid insulation not to exceed 4 in.
- 3C. **Substructure - (Bearing Plate)** (Optional) - Bearing plate to be used in lieu of gypsum board (Item 3) to be 4 by 4 in. by No. 18 MSG min thick coated steel (33 ksi min yield strength). Used under each clip (Item 2) over rigid insulation (Item 5) only when rigid insulation is located directly under panel (Item 1).

MAGNA-LOC

**Construction No. 506A
(cont.)**

October 16, 2001

Uplift - Class 90

Fire Not Investigated

4. **Vapor Barrier** (Optional) - Single ply, used between the substructure (Items 3, 3A or 3B) and panel (Item 1). To be min 30 lb roofing felt.
5. **Foamed Plastic** - (Rigid Insulation) (Optional) Max thickness 3-1/2 in. when gypsum board (Item 3), plywood (Item 3A) or OSB (Item 3B) is used and 6 in. when bearing plates (Item 3C) are used. Min bearing strength to be 20 psi. 1.8 pcf min density.
- 5A. **Insulation** (Optional) - Compressible blanket insulation 8 in. max thickness before compression. Used with sub-purlins (Item 7) only.
6. **Fasteners** - (Screws) Fasteners used to attach panel clips (Item 2) to sub-purlins (Item 7) to be No. 1/4-14 by 1 in. long self-drilling, self-tapping, hex-washer-head, plated steel screws. Two fasteners per clip. Fasteners used at end lap of panel (Item 1) to be one of the following: No. 1/4-14 by 1 in. long, Type AB point self-drilling, self-tapping, hex-washer-head, plated or stainless steel screws or No. 12-14 by 1-14 in. long self-drilling, self-tapping, hex-washer-head, plated steel screws. Spacing for 12 in. wide panel to be 1, 3, 4, 4, 3, 1 in. pattern. Spacing for 16 in. wide panels to be 1, 3, 4, 4, 3, 1 in. pattern; spacing for 18 in. wide panels to be 1-1/2, 3-1/2, 4, 4, 3-1/2, 1-1/2 in. pattern.
- 6A. **Fasteners** - (Screws) Fasteners used to attach panel clips (Item 2) through gypsum board, plywood, OSB, or bearing plate (Item 3, 3A, 3B, or 3C, respectively) and foamed plastic (Item 5) into liner panel (Item 8) to be No. 12-13, No. 3 Phillips drive, truss head, coated steel screws. Fastener length to penetrate liner panel min 1/2 in. Two fasteners per clip.
 Note: The panel clips may be fastened directly to the bearing plate using two No. 10-16 by 1 in. long self-drilling, self-tapping, pancake head No. 2 Phillips drive coated steel screws. The panel clip/bearing plate combination is to be fastened to the liner panel using two No. 12-13 truss head screws described above, inserted through guide holes in the bearing plates and into the liner panel. Min penetration 1/2 in.
- 6B. **Fasteners** - (Screws) (Not Shown) - Fasteners used to attach plywood Substructure (Item 3A) through rigid insulation (Item 5) to liner panel (Item 8) to be No. 14-13, No. 3 Phillips drive truss head screws. Fastener length to penetrate liner panel min 1/2 in. Total of 33 fasteners per 4 by 8 ft plywood sheet to be used. Fasteners located in five rows along the 4 ft length in a 3-9-12-12-9-3 in. pattern. The two outer rows are in a 3-9-12-12-12 12-12 12-9-3 in. pattern and the three center rows are in a 2-21-24-24-21-3 in. pattern. All spacing from board edges. Fasteners used to attach panel clips (Item 2) to plywood (when plywood is fastened to liner panel as indicated above) to be No. 10-12 by 1 in. long pancake head wood screw with No. 2 Phillips drive, or No. 10-12 by 1 in. long hex-head wood screw. Two fasteners per clip.
7. **Sub-Purlin** No. 16 MSG min thick coated steel (50 ksi min yield strength). Hat section, min 3/4 in. deep, 2 in. wide or Zee section, 2 in. wide, flanges 2 in. deep. Max spacing between sub-purlins to be 48 in. OC.
 Note: Screws used to attach sub-purlin to liner panel to be No. 12-13, No. 3 Phillips drive, truss head, coated steel. Max fastener spacing to be 12 in. OC for Zee section with fasteners located in center of lower flange. For hat section, two screws, spaced 24 in. OC, located at each side of channel to be used.
8. **Liner Panel** - (Steel Deck) No. 22 MSG min thick coated steel. Fabricated to various profiles (33 ksi min yield strength). Steel deck depth and profile, support spacing (max 6 ft), method of positioning (end and side laps), and fastening of deck to supports to be per deck manufacturer's and local code requirements for uplift loading.
9. **Liner Panel Supports** - Purlins No. 16 MSG min thick steel (50 ksi min yield strength). Spacing to depend on design considerations for uplift loading: max 6 ft, 0 in. OC.

Joists (Optional) - (Not Shown) - Open web steel joist having a min No. 16 MSG upper flange (50 ksi min yield strength) or a min 1/8 in. thick upper flange (33 ksi min yield strength). Max spacing 6 ft, 0 in. OC. Refer to general information, Roof Deck Construction, (Roofing Materials and System Directory) for items not evaluated.

*Bearing the UL Classification Mark

 Underwriters Laboratories Inc. ®
 LISTED

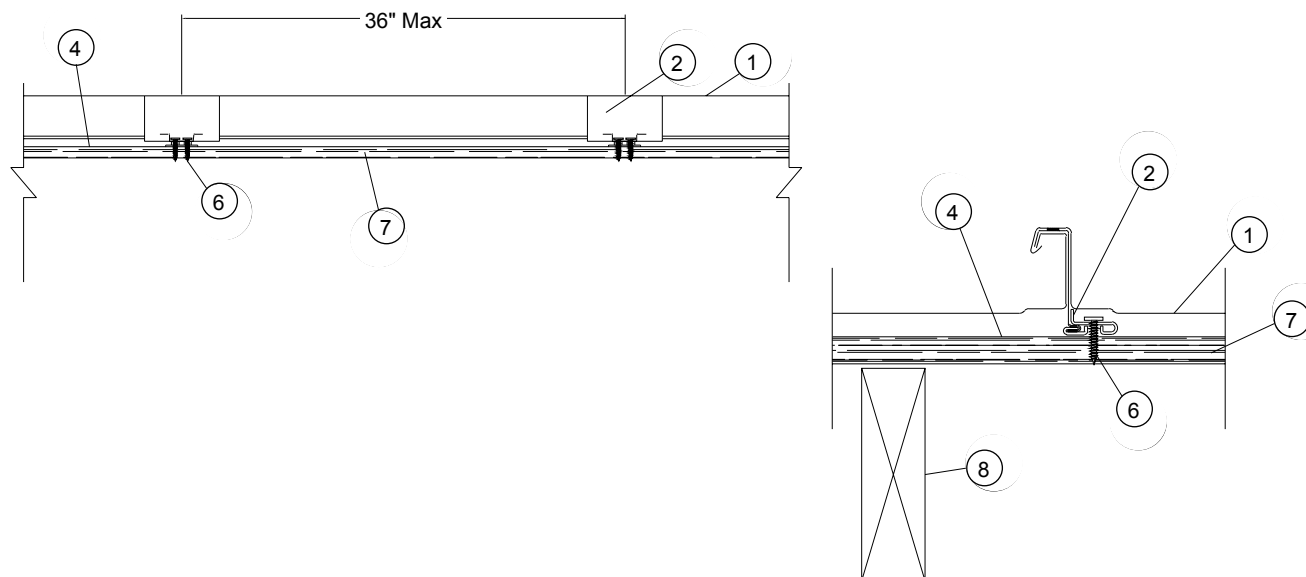

MAGNA-LOC

Construction No. 506B
 October 16, 2001
 Uplift - Class 90
 Fire Not Investigated

1. **Metal Roof Deck Panels*** No. 24 MSG min coated steel. Max panel width 18 in.; min 12 in. Rib height 2 in. Panels continuous over three or more clips (Item 2). The panel flat area may have optional striated or minor ribs placed at various locations in the panel flat area beginning min of 2 in. from side ribs. The upper flange of the panel rib may be horizontal, or optionally formed down to produce an angle of 0 to 90° between the vertical segment and the top flange of the rib. Panel end lap 2 in. min. An end lap back-up plate (Item 2A) to be used at panel end lap. A bead of sealant may be used at panel end lap and side ribs. Ribs to be seamed with an electric or hand seaming tool to form a flange with a tight hem. Seaming process to include the upper portion of the panel clips (Item 2) .
METAL SALES MFG CORP - "Magna-Loc 16", "Magna-Loc 18"
2. **Roof Deck Fasteners** - (Panel Clips) Located at side of panels (Item 1) over substructure (Item 3, 3A, 3B or 3C with max spacing of 36 in. OC), or plywood decking (Item 7 with max spacing of 36 in. OC). Either of the following:
Fixed Clip (Not Shown) - One piece assembly fabricated from No. 22 MSG min thick steel, 3-1/2 in. wide.
Floating Clip Two piece assembly with a base fabricated from No. 16 MSG min thick steel, 2 in. wide and a tab fabricated from No. 22 MSG min thick steel, 4-1/4 in. wide.
- 2A. **End Lap Back-Up Plate** (Not Shown) - No. 16 MSG min thick coated steel channel, 3 in. wide with two 3/8 in. deep legs. Max length 74 in. Located under the panel (Item 1) end lap (50 ksi min yield strength).
- 2B. **End Lap Back-Up-Plate** (Optional) (Not Shown) - No. 16 MSG min thick coated steel. Width 11, 13 or 19 in., length 7 in. Two 3/4 in. by 3/4 in. tabs and a 1 in. deep vertical leg located at up-slope edge of panel (50 ksi min yield strength).
- 2C. **Roof Deck Fasteners*(Cinch Plate)**-(Optional)-(Not Shown) width 1-5/16 in. length 18 in. max. Fabricated from No. 20 MSG min thick stainless steel. Located over end lap.
3. **Substructure - (Gypsum Board)** (Optional) - Min thick 1/2 in. To be placed on top of either the plywood decking (Item 7) or rigid insulation (Item 5). Combined thickness of the gypsum board and rigid insulation not to exceed 4 in. All joints to be taped with 2.5 in. wide joint tape.
- 3A. **Substructure - (Plywood)** (Optional) - (Not Shown) - Plywood decking, used in lieu of gypsum board (Item 3), to be no 1/2 in. thick, exposure 1 sheathing, 40/20, CD. Located over rigid insulation (Item 5). Combined thickness of the plywood and rigid insulation (Item 5) not to exceed 4 in.
- 3B. **Substructure - (OSB)** (Optional) - (Not Shown) - OSB decking, used in lieu of gypsum board (Item 3), to be nom 1/2 in. thick. Located over rigid insulation (Item 5). Combined thickness of the OSB and rigid insulation not to exceed 4 in.
- 3C. **Substructure - (Bearing Plate)** (Optional) - (Not Shown) - Bearing plate to be used in lieu of gypsum board (Item 3) to be 4 by 4 in. by No. 18 MSG min thick coated steel (33 ksi min yield strength). Used under each clip (Item 2) over rigid insulation (Item 5) only when rigid insulation is located directly under panel (Item 1).
4. **Vapor Barrier** (Optional) - Single ply, used between the substructure (Items 3, 3A or 3B) or plywood decking (Item 7) and panels (Item 1). To be min 30 lb roofing felt.

MAGNA-LOC

Construction No. 506B (cont.)
 October 16, 2001
 Uplift - Class 90
 Fire Not Investigated

5. **Foamed Plastic - (Rigid Insulation)** - (Optional) Max thickness 3-1/2 in. when gypsum board (Item 3), plywood (Item 3A) or OSB (Item 3B) is used and 6 in. when bearing plates (Item 3C) are used. Min bearing strength to be 20 psi. 1.8 pcf min density.
6. **Fasteners** - (Screws) Fasteners used to attach panel clips (Item 2) to plywood substructure (Item 3A) or plywood decking (Item 7) to be No. 10-12 pancake head, No. 2 Phillips drive, A-point, coated steel screw. Fastener length to penetrate plywood min 1/2 in. Two fasteners per clip.
- 6A. **Fasteners** - (Screws) Fasteners used to attach panel clips (Item 2) through gypsum board, OSB or bearing plate (Item 3, 3B, or 3C, respectively) and foam plastic insulation (Item 5) into plywood deck (Item 7) to be No. 10-12 pancake head, No. 2 Phillips drive, A-point, steel screw. Two screws used per clip.
 Note: The panel clips may be fastened to the bearing plate using two No. 10-16 by 1 in. long self-driving, self-tapping, pancake head No. 2 Phillips drive coated steel screws. The panel clip/bearing plate combination is to be fastened to the plywood deck using two No. 12-13 No. 3 Phillips Drive coated steel truss head screws, inserted through a guide hole in the clip and bearing plate and into the plywood deck.
- 6B. **Fasteners** - (Screws) (Not Shown) - Fasteners used to attach plywood Substructure (Item 3A) through rigid insulation (Item 5) into plywood deck (Item 7) to be No. 14-13, No. 3 Phillips drive truss head screws. Fastener length to penetrate plywood deck min 1/2 in. Total of 33 fasteners per 4 by 8 ft plywood sheet to be used. Fasteners located in five rows along the 4 ft length in a 3-9-12-12-9-3 in. pattern. The two outer rows are in a 3-9-12-12-12-12-12-9-3 in. pattern and the three center rows are in a 3-21-24-24-21-3 in. pattern. All spacing from board edges.
- 6C. **Fasteners** - (Screws) (Not Shown) - Fasteners used at end laps of panel (Item 1) to be one of the following: No. 1/4-14 by 1 in. long, Type AB point self-drilling, self-tapping, hex-washer-head, plated or stainless steel screws or No. 12-14 by 1-1/2 in. long self-drilling, self-tapping, hex-washer-head, plated steel screws. Spacing for 16 in. wide panels to be 1, 3, 4, 4, 3 in. pattern; spacing for 18 in. wide panels to be 1-1/2, 3-1/2, 4, 4, 3-1/2, 1-1/2 in. pattern.
7. **Plywood Deck** Plywood decking to be graded per PS83 specifications, 19/32 in. thick, exposure 1, APA rated sheathing, 40/20 in. OC, square edged. Butt ends not blocked.
8. **Purlins** - Deck Supports Spaced a max of 24 in. OC. Any of the following types may be used:
 - A. No. 22 MSG min thick coated steel. (33 ksi min yield strength.)
 - B. Graded dimension lumber, No. 2 or better.
- 8A. **Plywood Fasteners** (Not Shown) - Fasteners used to attach the plywood deck (Item 7) to the supports (Item 8) to be as follows:
 - a. For plywood-to-wood supports, No. 8-18 by 1-7/8 in. long bugle-head steel screws with a No. 2 Phillips drive, a "Hi-Low" thread pattern and an "S-Point".
 - b. As an alternate to Item a, No. 8d common deformed shank nails may be used.
 - c. For plywood-to-steel supports for a steel thickness less than No. 20 MSG, No. 7-19 by 1-1/4 in. long bugle-head steel screws with a No. 2 Phillips head drive, a "Hi-Low" thread pattern and an "S-Point". For a steel thickness greater than No. 20 MSG to No. 16 MSG, No. 6-20 by 1-1/4 in. long in. long bugle-head steel screws with a No. 2 Phillips drive and an S12 (Tek/3) point.
 Spacing - For all fastener types to be 6 in. OC at the plywood edges and 12 in. OC in the interior.
 Refer to general information, Roof Deck Construction, (Roofing Materials and System Directory) for items not evaluated.

*Bearing the UL Classification Mark

MAGNA-LOC

UL 263 FIRE RESISTANCE RATINGS

Metal Roof Deck Panels

Metal Sales Manufacturing Corporation has obtained fire resistance ratings for various products conducted according to test criteria set forth by 'Underwriters Laboratories' "Standard Fire Tests of Building Construction and Material" (ANSI/UL 263). This test procedure is identical to ASTM E-119 and NFPA 251.

The fire resistance rating is for the total assembly and not just the external metal panel. Ratings are expressed in hours and vary depending upon the assemblies.

In general, the test criteria is to evaluate the assembly's ability to continue to support the superimposed loads and resist the passage of flame, high temperatures, or hot gases which will ignite combustible materials. The test assemblies are identified by an alpha-numeric design number.

For detail information on specific assemblies and hourly ratings see UL Fire Resistance Directory.



Underwriters Laboratories Inc. ®
 LISTED

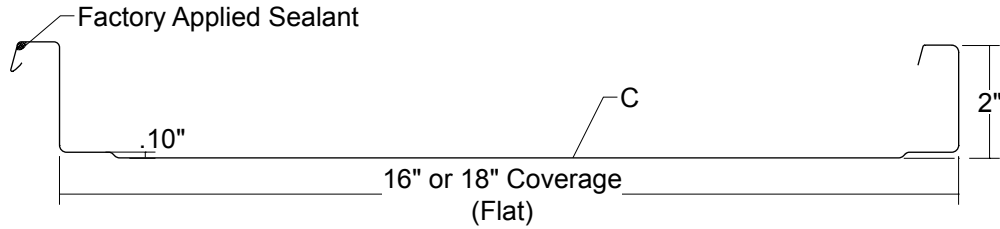

MAGNA-LOC SECTION PROPERTIES									
GAUGE	WIDTH in	YIELD ksi	WEIGHT psf	TOP IN COMPRESSION			BOTTOM IN COMPRESSION		
				Ixx in ⁴ /ft	Sxx in ³ /ft	Ma (k-in)/ft	Ixx in ⁴ /ft	Sxx in ³ /ft	Ma (k-in)/ft
24	16"	50	1.25	.1785	.1013	3.03	0.0855	0.0754	2.69
22	16"	50	1.63	.2468	.1419	4.25	0.1178	0.1066	3.59
24	18"	50	1.21	.1620	.0900	2.69	0.0760	0.0669	2.40
22	18"	50	1.58	.2233	.1255	3.76	0.1047	0.0947	3.19

ALLOWABLE UNIFORM LIVE LOADS PSF 2 or more Equal Spans															
GAUGE	WIDTH in	YIELD ksi	WEIGHT psf	Inward Load						Outward Load					
				2.5'	3'	3.5'	4'	4.5'	5'	2.5'	3'	3.5'	4'	4.5'	5'
24	16"	50	1.35	283	206	156	122	97	80	410	300	229	180	144	119
22	16"	50	1.74	401	287	215	167	133	108	609	440	332	259	207	169
24	18"	50	1.31	252	183	139	108	87	71	364	267	203	160	128	105
22	18"	50	1.69	356	255	191	148	118	96	539	390	294	229	183	150

ALLOWABLE UNIFORM LIVE LOADS PSF 3 or more Equal Spans															
GAUGE	WIDTH in	YIELD ksi	WEIGHT psf	Inward Load						Outward Load					
				2.5'	3'	3.5'	4'	4.5'	5'	2.5'	3'	3.5'	4'	4.5'	5'
24	16"	50	1.35	161	126	101	82	68	57	65	60	55	50	45	40
22	16"	50	1.74	257	197	155	125	103	86	86	80	73	67	61	55
24	18"	50	1.31	144	112	89	73	61	51	68	62	56	50	43	37
22	18"	50	1.69	160	128	104	87	74	63	78	73	68	62	57	52

1. Theoretical section properties have been calculated per AISI 2001 "Specification for the Design of Cold-formed Steel Structural Members." Ixx and Sxx are effective section properties for deflection and bending.
2. Allowable load is calculated in accordance with AISI 2001 specifications considering bending, shear, combined bending and shear, deflection, and ASTM 1592 testing. Allowable load considers the worst case of 3 and 4 equal span conditions. Allowable load does not address web crippling or fasteners/support connection and panel weight is not considered.
3. Deflection consideration is limited by a maximum deflection ratio of L/180 of span.
4. Allowable loads do not include a 1/3 stress increase in uplift.

RECEIVING MATERIAL

It is the responsibility of the installer to unload material from the delivery truck. The installer shall be responsible for providing suitable equipment for unloading of material from the truck.

After receiving material, check the condition of the material, and review the shipment against the shipping list to ensure all materials are accounted for. If damages or shortages are discovered, it should be noted on the Bill of Lading at the time of delivery. A claim should be made against the carrier as soon as possible. Metal Sales is not responsible for any damages or shortages unless they are documented in writing and presented to Metal Sales within 48 hours.

GENERAL HANDLING

Each bundle should be handled carefully to avoid being damaged. Care should be taken to prevent bending of the panel or abrasion to finish. Whenever possible, the bundle should remain crated until it is located in its place of storage. If bundles must be opened, we recommend you recreate them before lifting. To avoid damage please lift the bundle at its center of gravity.

CAUTION

Improper loading and unloading of bundles and crates may result in bodily harm and/or material damage. Metal Sales is not responsible for bodily injuries and/or material damages resulting from improper loading and unloading.

MECHANICAL HANDLING

Forklift - A forklift may be used for panels up to 20'-0" long. Please make sure the forks are at their maximum separation. Do not transport open bundles. When transporting bundles across rough terrain, or over a longer distance, some means of supporting the panel load must be used.

Crane - A crane should be used when lifting panels with lengths greater than 20'-0". Please be sure to utilize a spreader bar to ensure the even distribution of the weight to the pick up points. As a rule when lifting panels, no more than $\frac{1}{3}$ of the length of the panel should be left unsupported. Never use wire rope because this will damage the panels.

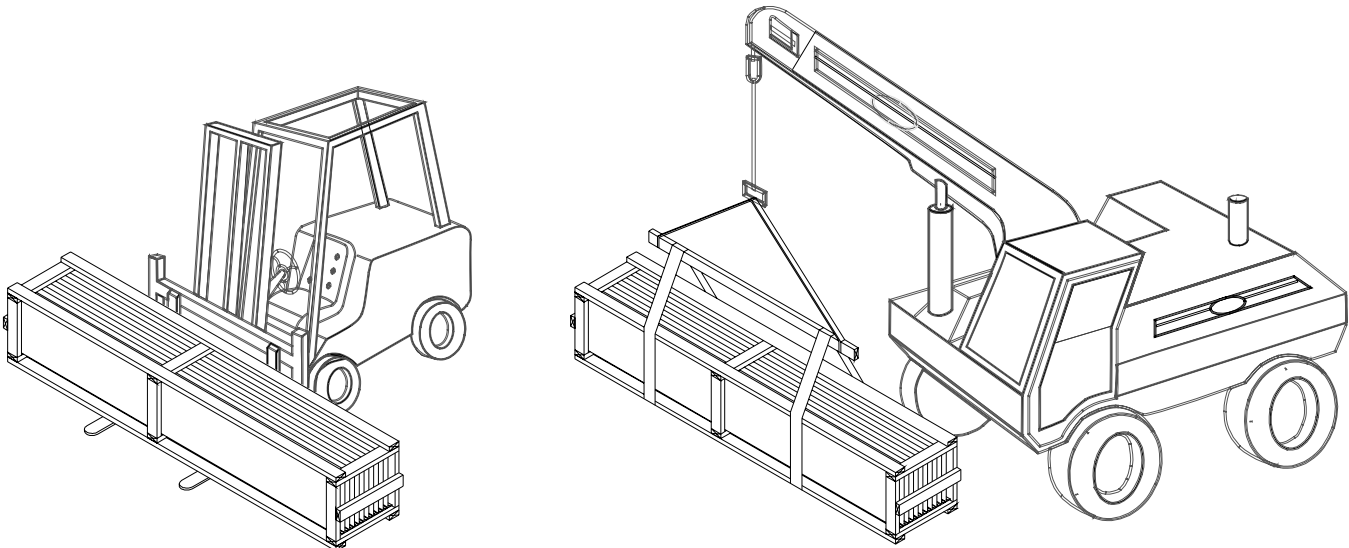

MANUAL HANDLING

When handling painted steel care should be taken to prevent scratching of material. Clean gloves should be worn at all times to prevent a reaction with salts found on bare skin. Installers should wear rubber sole shoes to keep from scuffing material while walking on the roof.

Handling of individual panels should be done carefully and properly to avoid bending or damaging. Magna-Loc panels should be carried by grasping the edge of the panel so that the Magna-Loc panel is vertical to the ground. The Magna-Loc panel should not be carried with the panel horizontal to the ground as this could cause the panel to buckle or bend in the center.

Normally individual panels can be handled by people placed every 6'-0" to 8'-0" along the length of the panel.

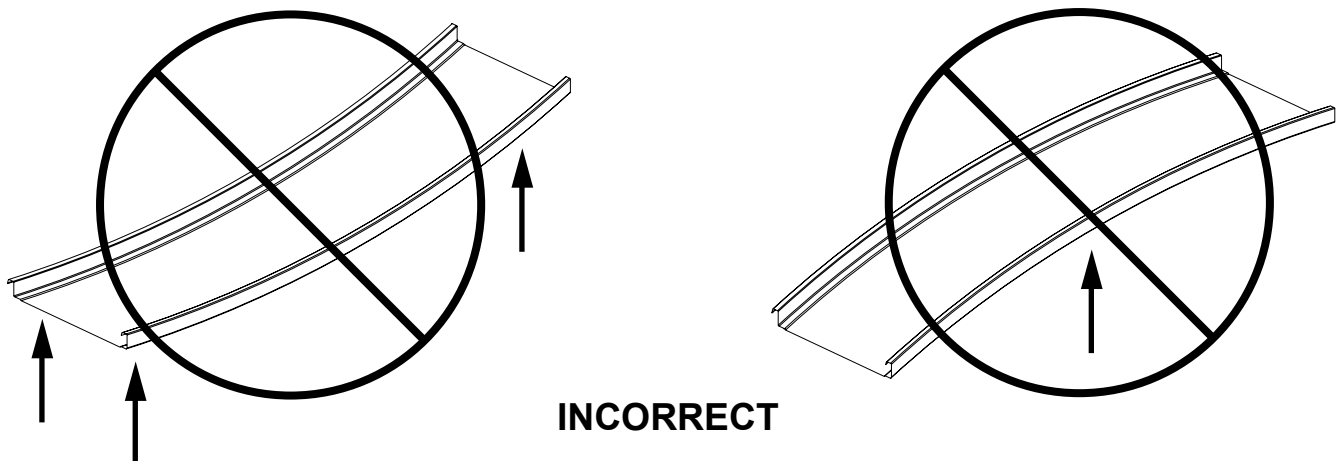
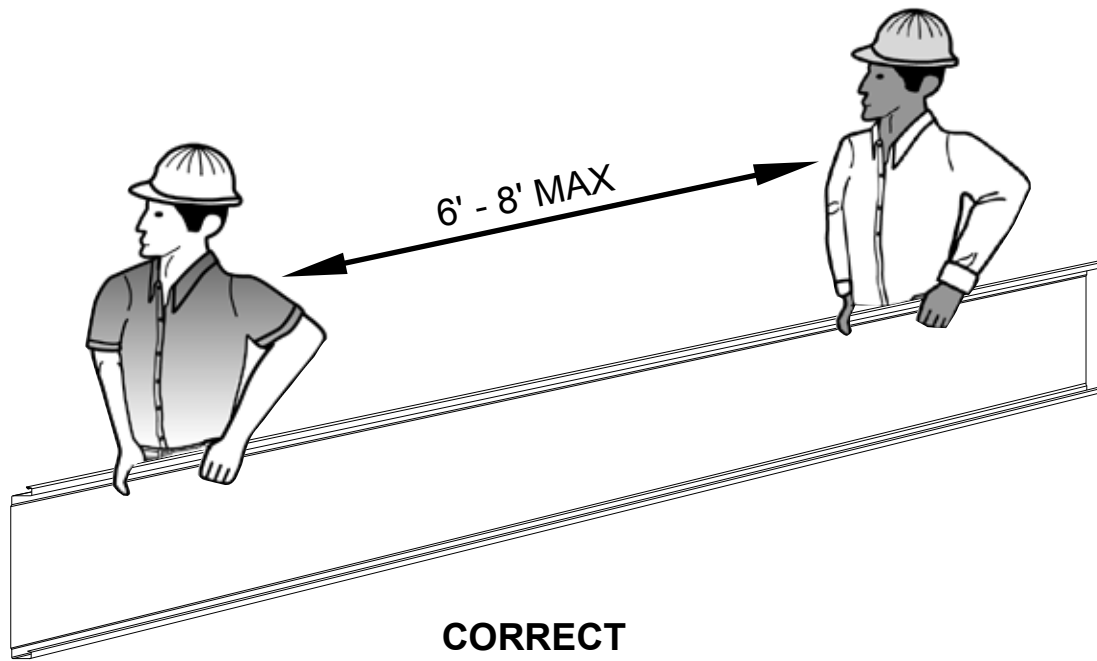

GENERAL

Please inspect panels for moisture accumulation. If moisture has formed, the panels should be unbundled, wiped dry, and allowed to dry completely. Once dry, carefully re-stack the panels and loosely recover allowing for ample air circulation.

Bundled sheets should be stored high enough off of the ground to allow for air circulation and prevent contact with accumulating water. If possible, elevate one end of the bundle to allow any moisture to run off the panels. Metal Sales recommends covering the bundle with a tarpaulin. Do not use tight fitting plastic-type tarpaulins as panel bundle covers. While they may provide protection from heavy downpours, they can also retard necessary ventilation and trap heat and moisture that may accelerate metal corrosion. If panels are to be stored in possible bad weather, we suggest they be stored inside. Extended storage of panels in a bundle is not recommended. **Under no circumstances should the sheets be stored near or come in contact with salt water, corrosive chemicals, ash, or fumes generated or released inside the building or nearby plants, foundries, plating works, kilns, fertilizer, and wet, green treated lumber.**

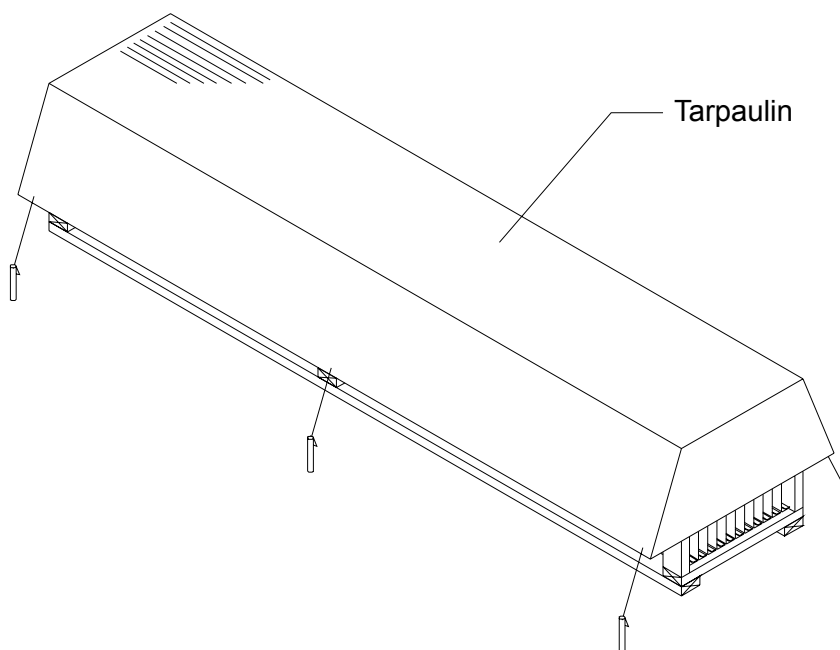
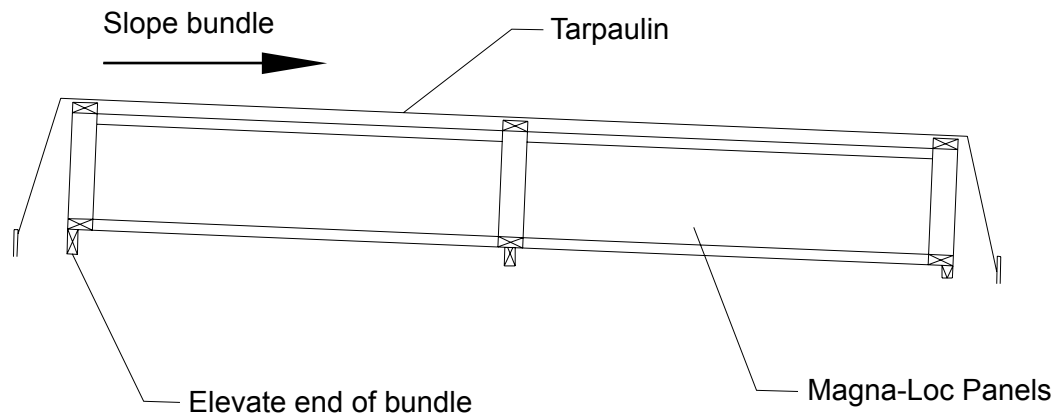

STORAGE ON ROOF

To facilitate the handling of Magna-Loc panels, panel bundles can be lifted and placed on the roof. Bundles need to be placed on the roof in order for the roof structure to handle the weight. Loading capabilities of the structure must be checked.

When lifting packaged sheets, make certain they are adequately supported. Panels less than 20'-0" in length can normally be lifted with a forklift; however, when lifting panels in excess of 20'-0", it is recommended that a spreader bar and slings be used. As a rule, when lifting, no more than $\frac{1}{3}$ of the length of the panel should be left unsupported.

Make a plan for bundle placement by determining how much area a bundle of panels will cover. Bundles should be placed on the roof in accordance with the direction the panel will be installed. Consider where the string line, if any, is to run at the eave to set roof panels by. Roof bundles should not interfere with this string line.

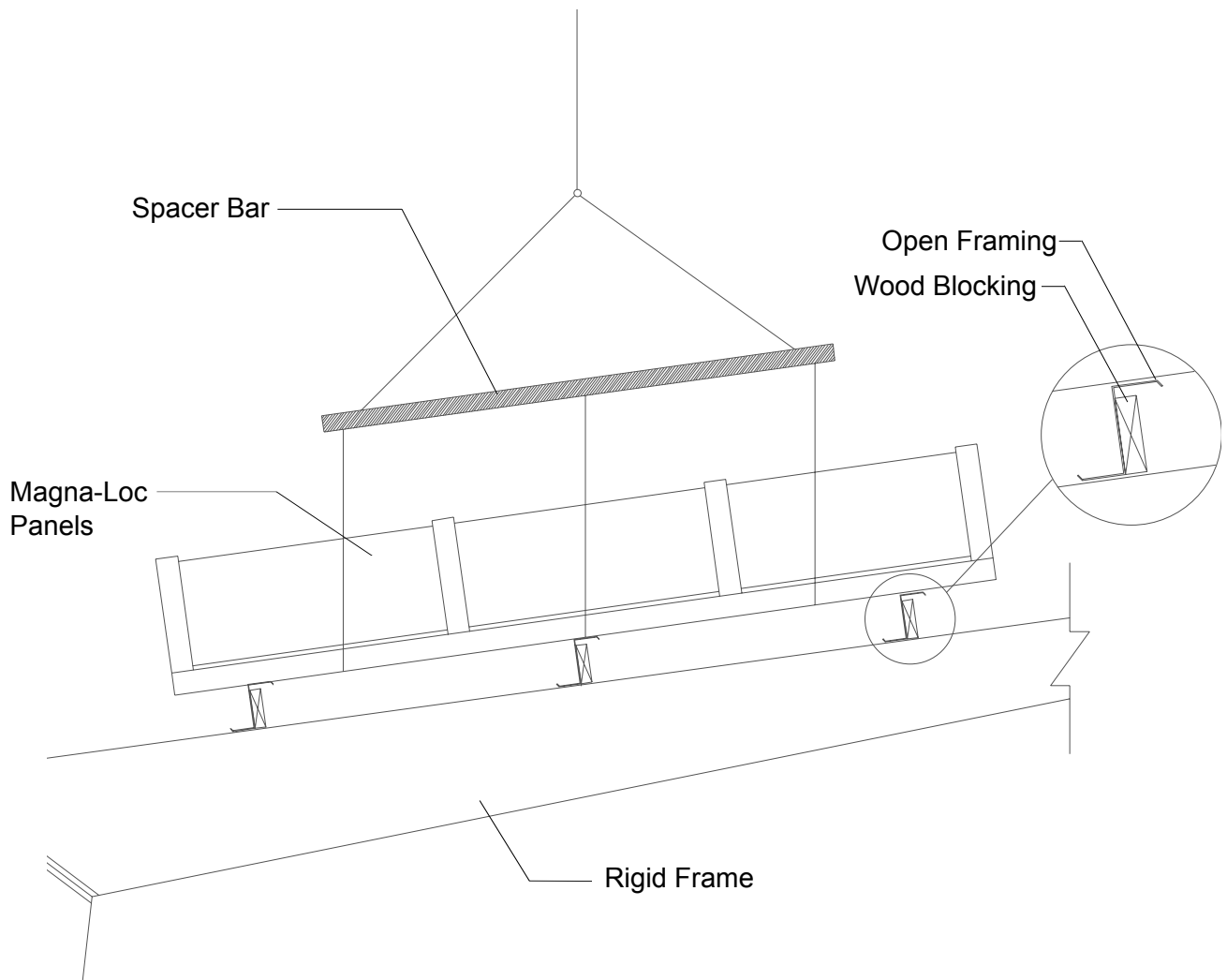

Care of metal panels and flashings must be exercised throughout erection. Foot traffic can cause distortion of panel and damage to finish. Traffic over the installed system must be kept to an absolute minimum. If continuous foot traffic is necessary for maintenance over certain areas of the roof, then a permanent walkway should be installed.

If metal panels are installed over open framing, do not use the roof panel as a walking platform. The roof panels will not withstand the weight of a person standing at the edge of the panel. Provide walking platforms to avoid any panel damage as shown below.

When walking on the roof panels is unavoidable, walk only in the flats of the panel. Walking on the ribs can cause damage to the panels. If Magna-Loc is installed over open framing, step in the flat of the panel only and as close to the framing as possible.

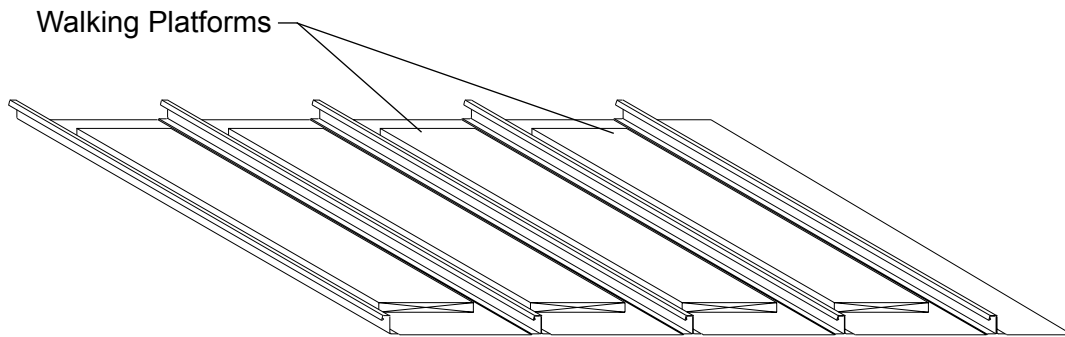

OVER OPEN FRAMING

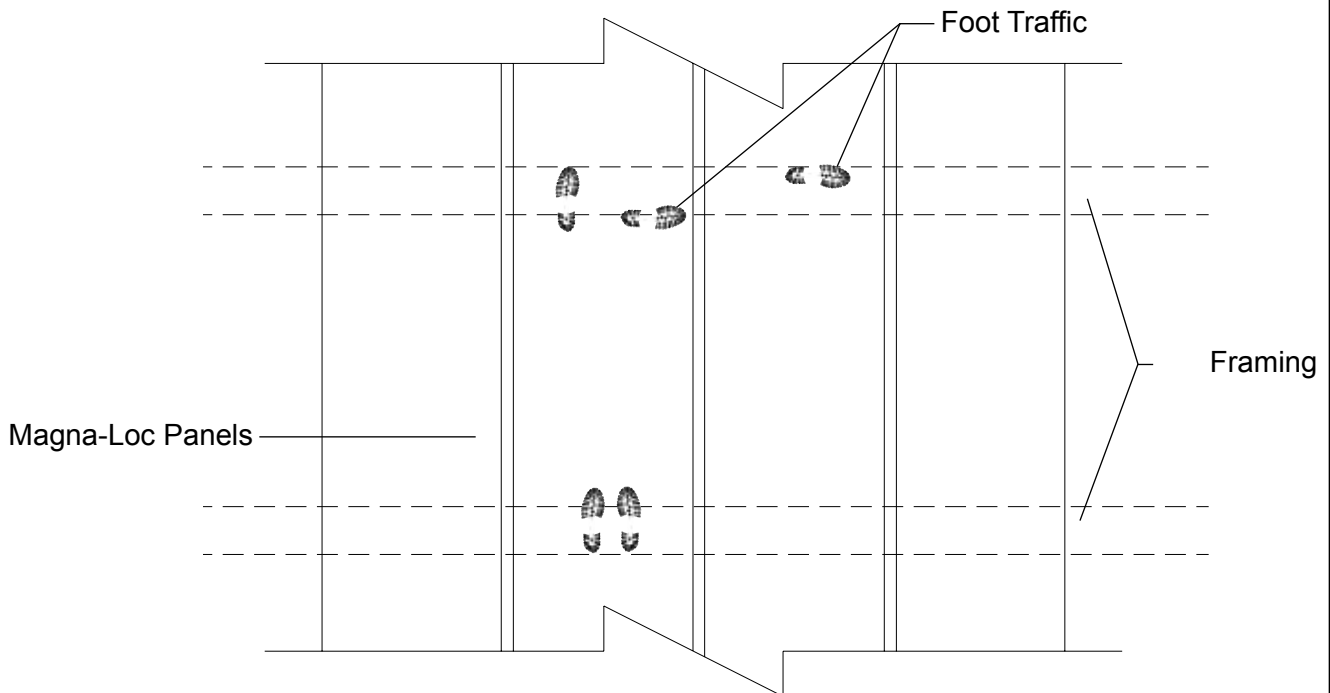

FIELD CUTTING

Tin snips or a "nibbler" type electric tool are recommended for field cutting Magna-Loc panels. Cutting the steel generates slivers or metal chips. These slivers and metal chips must be immediately removed from the Magna-Loc panels because they will damage the finish and shorten the life of the product.

One method of preventing this problem is to flip the Magna-Loc panels over when cutting. This allows the slivers and metal chips to be brushed from the back side and avoids damaging the paint on the top side of the panels.

When cutting Magna-Loc panels, goggles must be worn for eye protection.

CAUTION

All product surfaces should be free of debris at all times. Installed surfaces should be wiped clean at the end of each work period. Never cut panels over metal surfaces. Metal shavings will rust on the surface, voiding the warranty.

TOUCH-UP PAINT

All painted panels and flashings have a factory applied baked on finish. Handling and installing panels may result in some small scratches or nicks to the paint finish. Touch-up paint is available in matching colors from Metal Sales. It is recommended that a small brush be used to apply touch-up paint to those areas that are in need of repair. Touch-up paint does not have the superior chalk and fade resistance of the factory applied paint finish and will normally discolor at an accelerated rate. Aerosol paint should not be used because of the overspray that may occur.



SPRAY PAINT

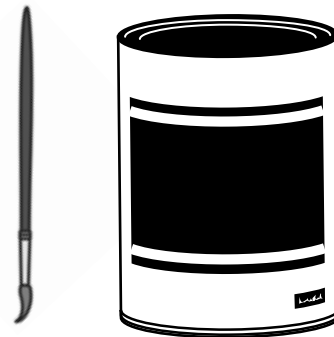

TOUCH-UP PAINT

FASTENER INSTALLATION TECHNIQUE

Recommended Tool Type - Use depth locating nose or adjustable clutch on screw gun to prevent overdrilling and strip out. **Do not use impact tools or runners.**

Seating the washer - Apply sufficient torque to seat the washer - do not overdrive the fastener.

	CORRECT Sealing material slightly visible at edge of metal washer. Assembly is watertight.	TOO LOOSE Sealing material is not visible; not enough compression to seal properly.	TOO TIGHT Metal washer deformed; sealing material pressed beyond washer edge.
SELF DRILLER			
WOODSCREW			

To prevent wobbling - Make sure fastener head is completely engaged in the socket. If the head does not go all the way in the socket - tap the magnet deeper into the socket to allow full head engagement. Metal chips will build up from drilling and should be removed from time to time.

Protect drill point - Push only hard enough on the screw gun to engage clutch. This prevents excess friction and burn out of the drill point. Correct pressure will allow screw to drill and tap without binding.

Drilling through sheet and insulation - Ease up on pressure when drilling through insulation to avoid striking the purlin or girt with the point - apply more pressure after drill point contacts purlin or girt.

Drilling through purlin overlaps - Drilling through lapped purlins requires extra care. Excessive voids between purlins sometimes damages drill points and two self-drillers might be necessary to complete the operation. It is sometimes advantageous to predrill.

CONDITION OF SUBSTRUCTURE

Whether over solid substrate or open structural framing, panel distortion may occur if not applied over properly aligned and uniform substructure.

The installer should check the roof deck for squareness before installing Magna-Loc panels. Several methods can be used to verify squareness of the structure for proper installation of the panels.

METHOD "A" - One method for checking the roof for squareness is to measure diagonally across one slope of the roof from similar points at the ridge and eave and obtain the same dimension.

METHOD "B" - The 3-4-5 triangle system may also be used. To use this system measure a point from the corner along the edge of the roof at a module of three (3). Measure a point from the same corner along another edge at a module of four (4). Then by measuring diagonally between the two points established, the dimension should be exactly a module of five (5) to have a square corner. Multiple uses of this system may be required to determine building squareness. If the endwall cannot be made square, the roof system cannot be installed as shown in these instructions.

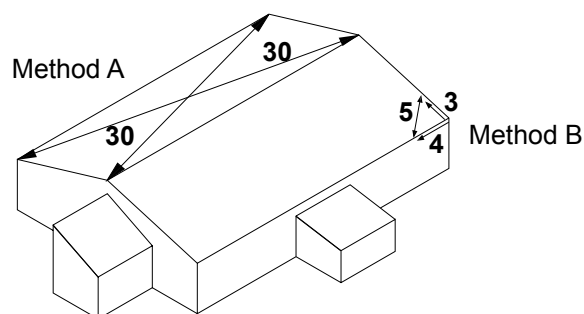

VENTILATION

Proper design and installation of vapor barriers and ventilation systems are important to prevent condensation and the resulting problems of moisture damage and loss of insulation efficiency.

Condensation occurs when moisture laden air comes in contact with a surface temperature equal to or below the dew point of the air. This phenomenon creates problems that are not unique with metal buildings; these problems are common to all types of construction.

The underside of the metal roof on a typical metal building (no attic) should be protected from condensation by insulating with a faced insulation. This should reduce the potential of condensation forming on the underside of the panels.

On buildings that have an attic space or are being retrofitted with a metal roofing system, vents should be placed at both the eave and peak of the roof in order to prevent a buildup of moisture (humidity) in the attic space.

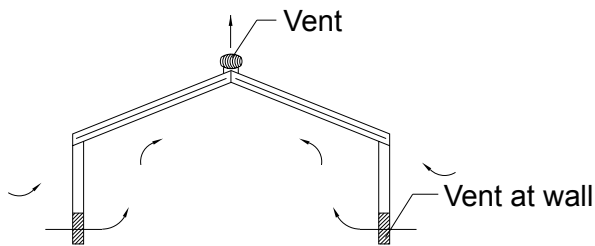

TYPICAL METAL BUILDING (NO ATTIC)

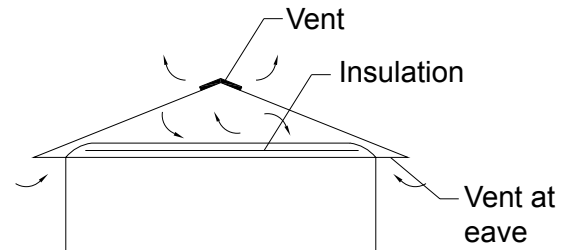

BUILDING WITH ATTIC OR RETROFITTED

INSULATION

In most cases insulation is installed directly under roof panels. Insulation is recommended on all applications to act as a sound barrier, prevent condensation, and increase insulating value of a roof system.

Many different types of insulation can be used with the metal roof panels. Blanket, batt, rigid, and reflective insulation are just to name a few. Please contact your insulation supplier for specific recommendations on installation of insulation and vapor barriers.

When applying a compressible type of insulation over open framing members. Rigid thermal blocks can be used to help eliminate heat lost at purlin locations.

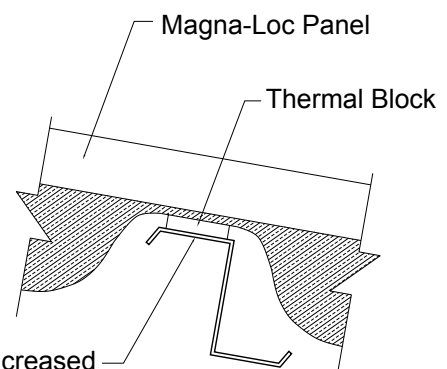
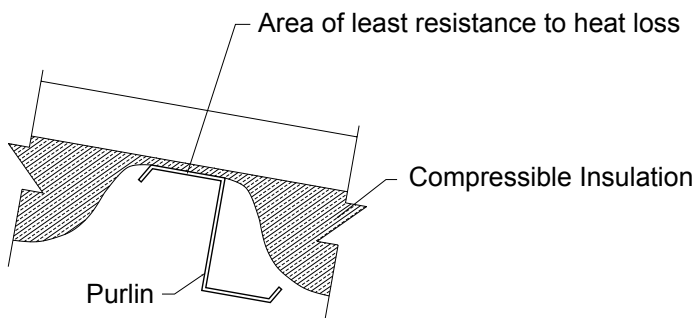

CAUTION

Use extreme care when working next to insulation. The insulation will provide a false sense of security by hiding the view of the ground below

SYSTEM EXPANSION / CONTRACTION

Steel roofing panels are subject to dimensional changes after installation due to exposure to varying temperatures. The greatest influence is solar energy. Steel roofing absorbs various amounts of heat depending upon color, finish, angle of exposure, and time of exposure.

The relationship of the roof temperature to building structural temperature must be considered when designing a Magna-Loc roof system. The floating clips for the Magna-Loc panels are designed for expansion and contraction of the panels in the longitudinal direction. Lateral expansion and contraction is accommodated by the configuration of the panel cross section and causes negligible panel movement.

When the total length of panel run exceeds the capability of the clips to accommodate the thermal movement, expansion joints must be designed into the structure.

SELECTION OF SYSTEM COMPONENTS

The Magna-Loc roof system can be installed with components that allow the panels to either float independently or fix permanently to the substructure. Choice of system will depend upon building design and regional temperature range (from summer highs to winter lows).

SYSTEM COMPONENTS					
SYSTEM	CLIP	EAVE PLATE	RAKE ZEE	THERMAL BLOCK	INSULATION
UTILITY	2 1/8" UTILITY (FIXED ONLY)	NONE REQUIRED	2 1/8" UTILITY	NONE REQUIRED	1/2" TO 4" BLANKET
LOW	2 3/8" LOW (FLOATING OR FIXED)	3/8" LOW	2 3/8" LOW	NONE REQUIRED	4" TO 6" BLANKET
HIGH	3 3/8" HIGH (FLOATING)	1 3/8" HIGH	3 3/8" HIGH	1"	4" TO 6" BLANKET

Magna-Loc Floating Clips- The floating clips allow the roof surface (panels) to move independently of the roof substructure to allow for thermal expansion and contraction. These clips are designed with a vertical tab that slides along the base section of the clip.

Magna-Loc Fixed Clips- Fixed clips may be used on panel runs of less than 20'-0", unless thermal expansion and contraction is a consideration. When utilizing a Fixed Utility Clip, a Pancake Head fastener must be used.

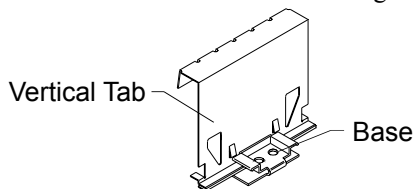

MAGNA-LOC FLOATING CLIP

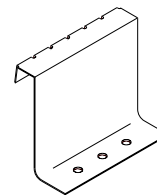

MAGNA-LOC FIXED CLIP

The following chart should be used to determine proper fasteners required for clip installation on the selected applications. (See Fastener Selection Guide page 17 for other fasteners available.)

APPLICATION	INSTALLATION REQUIREMENTS		**CLIP SPACING	TYPE OF FASTENER	NUMBER REQUIRED
CLIPS OVER PURLINS (16 GA. MIN)	STANDARD	24 GAUGE	5'-0" O.C.	1/4-14 x 1 1/2" SELF DRILLER NW	2 FASTENERS
	STANDARD	22 GAUGE	5'-0" O.C.	1/4-14 x 1 1/2" SELF DRILLER NW	2 FASTENERS
CLIPS OVER 5/8" WOOD DECK	STANDARD	24 GAUGE	4'-0" O.C.	#12-11x1 1/2" LOW PROFILE WOODSCREW	2 FASTENERS
	STANDARD	22 GAUGE	4'-0" O.C.	#12-11x1 1/2" LOW PROFILE WOODSCREW	2 FASTENERS
CLIP OVER RIGID INSULATION / METAL DECK	STANDARD	24 GAUGE	4'-0" O.C.	DEKFAST #14*	2 FASTENERS
	STANDARD	22 GAUGE	4'-0" O.C.	DEKFAST #14*	2 FASTENERS

* Length of Dekfast will vary depending on the total thickness of the rigid insulation and metal. (See page 22.)

** Contact your local Metal Sales branch representative for more information. (See pages 2 and 3.)

Factory Notched Panels - Metal Sales can provide factory notched panel ends to eliminate material-build up or reliance on field notching for weathertight seams at panel endlaps.

Factory Pre-punched Panels - Metal Sales can provide panels that have been factory punched with holes for proper placement of fasteners at panel endlaps.

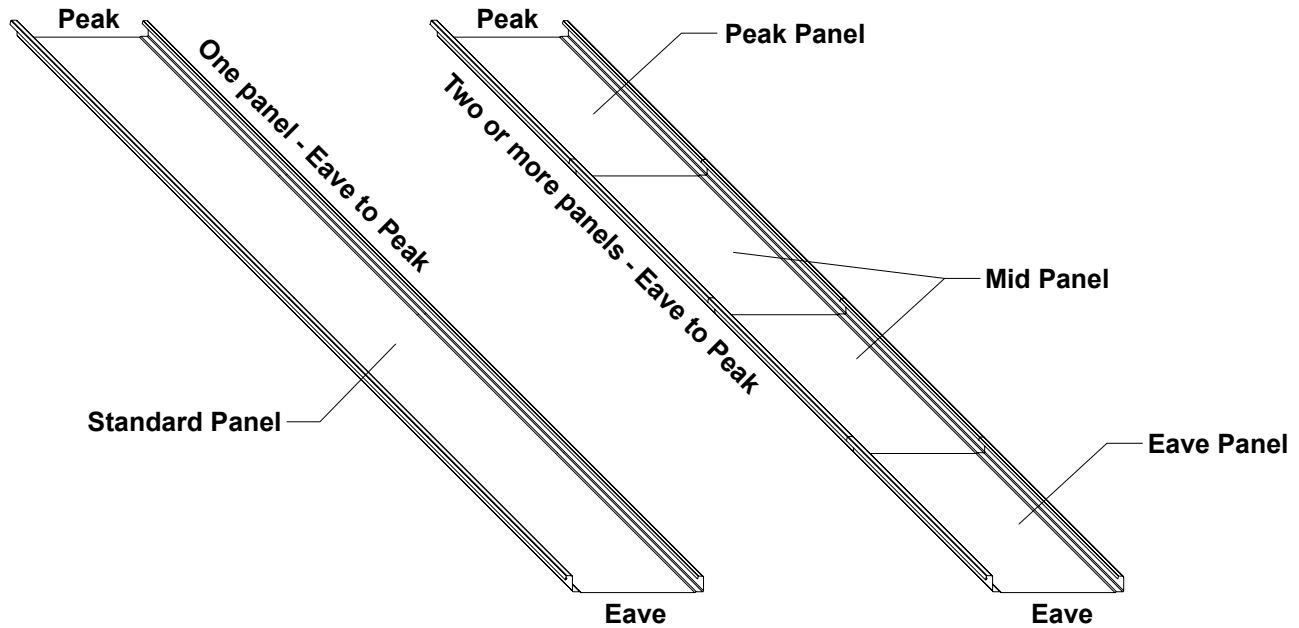

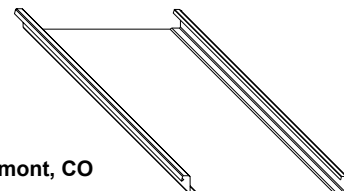
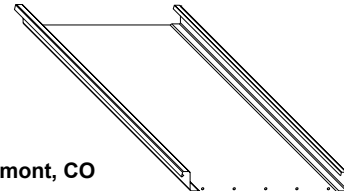
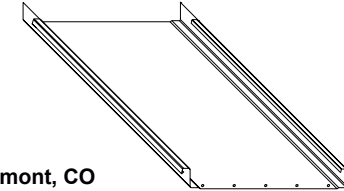
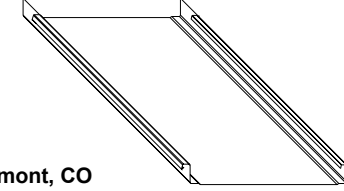
<p><u>STANDARD PANEL:</u></p> <ul style="list-style-type: none"> ▶ Used when endlapping of panels is not required ▶ One panel from eave to peak of roof ▶ No notching ▶ No punching 	 <p>*Longmont, CO **Sellersburg, IN</p>
<p><u>PEAK PANEL:</u></p> <ul style="list-style-type: none"> ▶ Used when endlapping of panels is required ▶ Used as upper panel of endlapping run ▶ Pre punched holes for endlap fastener placement ▶ No notching <p>*Panel is notched and punched both ends or neither</p>	 <p>*Longmont, CO **Sellersburg, IN</p>
<p><u>MID PANEL:</u></p> <ul style="list-style-type: none"> ▶ Used on runs where more than (2) panels are needed from eave to peak ▶ Not required if only (2) panels are used from eave to peak ▶ Notched for panel endlapping ▶ Pre-punched holes for endlap fastener placement 	 <p>*Longmont, CO **Sellersburg, IN</p>
<p><u>EAVE PANEL:</u></p> <ul style="list-style-type: none"> ▶ Used when endlapping of panels is required ▶ Used as lower panel of endlapping run ▶ Notched for panel endlapping ▶ No punching <p>*Panel is notched and punched both ends or neither</p> <p>**Notch trailing end only</p>	 <p>*Longmont, CO **Sellersburg, IN</p>

The following procedures (pages 22-47) are presented as a general guide for installing Magna-Loc panels, flashings, and accessories on a typical building or residence. Details are shown for installing Magna-Loc and related flashings over solid decking and over open framing. For other applications please contact your nearest Metal Sales location (See pages 2 and 3).

The installation procedures will involve:

- Installation of Floating Rake Zee. (page 22)
- Installation of Eave plate.
- Installing panel from left to right (Looking from Eave to Peak.)
- Panel Clip installation.
- Endlapping of panel.
- Sidelapping of panel.
- Termination of panel.
- Seaming panels.
- Eave condition installation.
- Gutter condition installation.
- Valley condition installation.
- Endlap condition installation.
- Rake condition installation.
- Rakewall condition installation.
- Expansion Joint condition installation.
- Endwall condition installation.
- High Side Eave condition installation.
- Ridge / Hip condition installation.

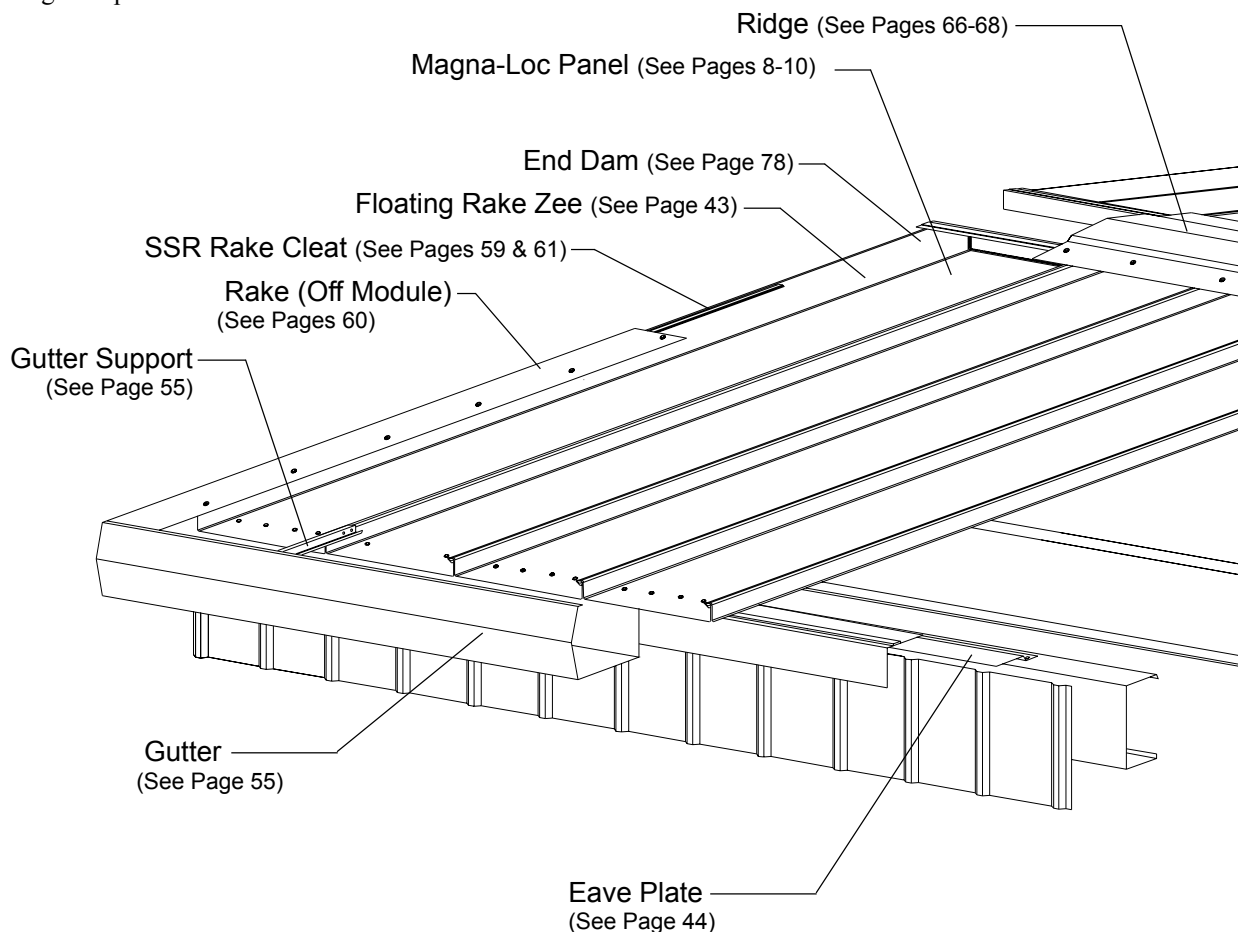

INSTALLING FLOATING RAKE ZEE

STEP 1

Note: The Floating Rake Zee must be attached to the framing member along the rake. Size of Floating Rake Zee can vary, (see System Components list on page 20). The following procedures are based on systems utilizing floating panel clips. For systems utilizing fixed panel clips, the Floating Rake Zee is not required to move along its slotted base, (see step 2).

Steps:

1. At the eave of the building (looking eave to peak), align the Floating Rake Zee flush with the existing rake angle/framing. **It is critical that the Floating Rake Zee be straight and square with the building as it controls the alignment of the roof panels.**
2. Fasten Floating Rake Zee with ¼"-14 x 1¼" Shoulder Self Driller screws into the center of each slot, (12" intervals). **Do not overtighten screws. Movement of the Floating Rake Zees are imperative for proper installation of the roof system.**

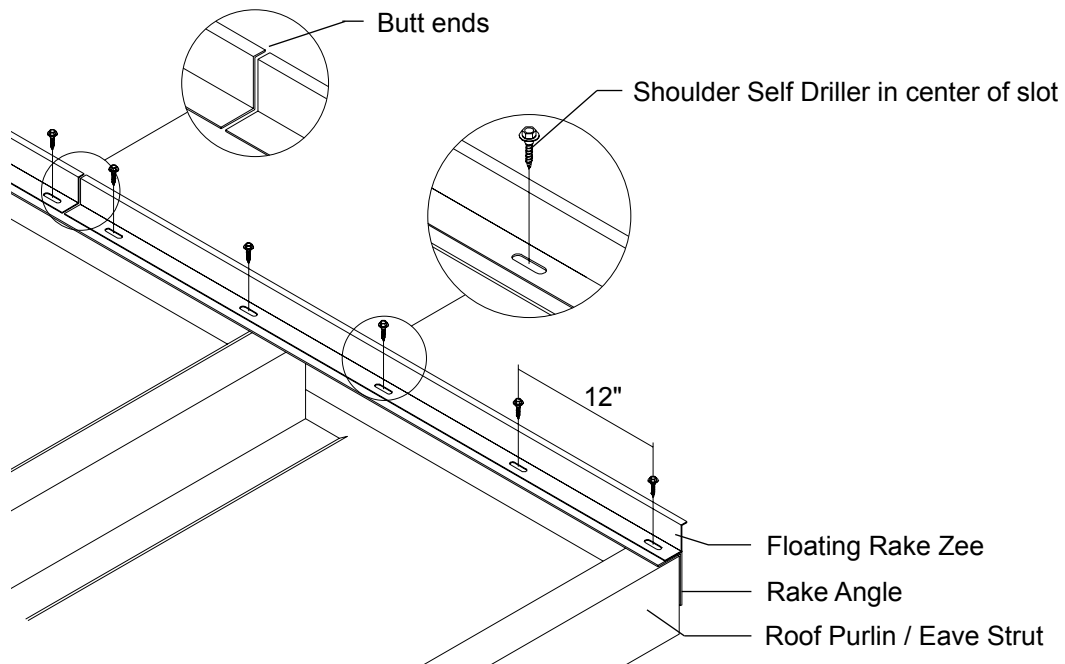

3. If two or more Floating Rake Zees are required, butt ends of Floating Rake Zees (**Do not overlap**) and continue fastening.
4. If necessary, field cut Floating Rake Zee to terminate 6"-12" from peak of building.
5. Install Floating Rake Zee on the opposite end where the panels terminate using the same procedures as above.

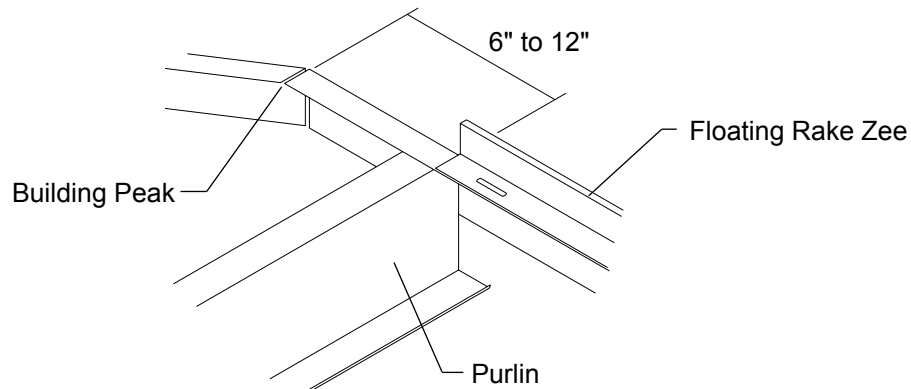

6. After applying Floating Rake Zees, insulation (if required) can be installed. Roll out insulation eave to peak, laying side of insulation on Floating Rake Zees.
7. Avoid side lap of insulation from occurring directly beneath side lap of panel.

INSTALLING EAVE PLATE

STEP 2

Note: The Eave Plate serves as an extension of the structure to support and fasten (if required) the panel at the eave on applications utilizing the Low or High Floating Clip Systems. Size of Eave Plate can vary (see System Components list on page 20).

Steps:

1. If using blanket insulation, the Eave Plate may be used to secure the insulation at the eave. Be sure to remove the fiberglass and fasten only the vapor barrier to avoid wicking.
2. Place pre-punched leg of Eave Plate on top of eave framing member. Align the top leg of the Eave Plate flush with the finished wall surface at the eave of the building.

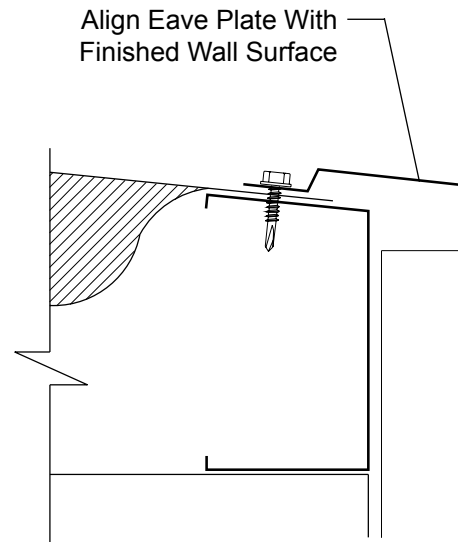

3. Fasten Eave Plate to eave framing member with #12 -14 x 1" or #12 -14 x 1 1/4" Self Driller No Washer screws 12" o.c. **Do not fasten through Eave Plate into Floating Rake Zee. Movement of the Floating Rake Zee is imperative for proper installation of roof system.**
4. If two or more Eave Plates are required, butt ends of the Eave Plates (**Do Not Overlap**) and continue fastening.

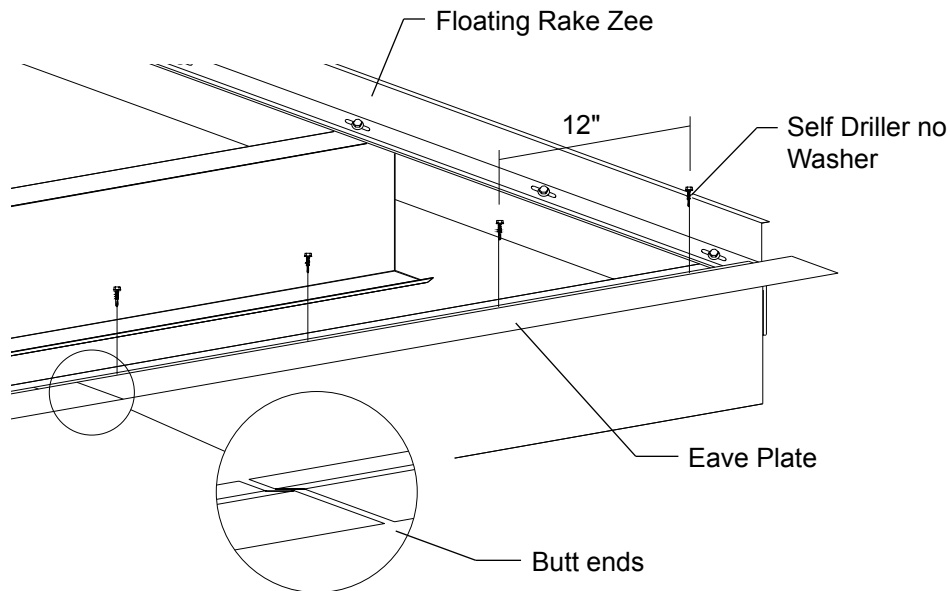

INSTALLING FIRST PANEL

STEP 3

Note: Eave, Gutter Drip, Gutter, Valley, or any low side flashing must be installed prior to installation of roof panel. The following steps are for installing Magna-Loc from left to right. Magna-Loc may be installed from right to left if end lapping of panels is not required (See page 60 for Off Module panel installation).

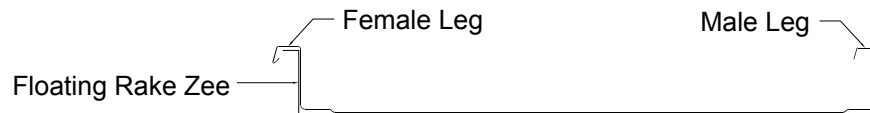

Steps:

1. Place a row of Double Bead Tape Sealant across top of Gutter Drip flashing. Be sure to place sealant where fastener will be placed.
2. Position the first panel so the female leg is on top of the Gutter Drip and the panel is against the vertical leg of the Floating Rake Zee.
3. Slide the panel over the eave flashing, 2" past the finished wall surface.
4. Use a C-clamp to hold the panel against the vertical leg of the Floating Rake Zee. Lift panel at the Eave Plate and strip off the paper backing on the Double Bead Tape Sealant.

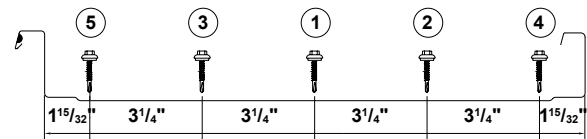
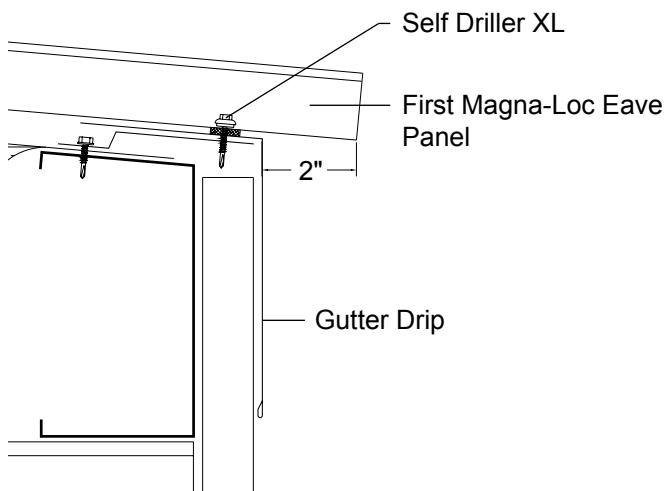

16" PROFILE FASTENING PATTERN
(Additional fasteners may be required at valley condition)

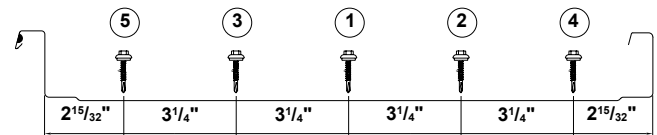

18" PROFILE FASTENING PATTERN
(Additional fasteners may be required at valley condition)

5. Recheck the panel overhang dimension at Eave, Ridge, and Endlap if required, and adjust if necessary.
6. Fasten panel through the Double Bead Tape Sealant and Gutter Drip flashing into the Eave Plate using (5) #12-14 x 1¹/₄" Self Driller XL screws.

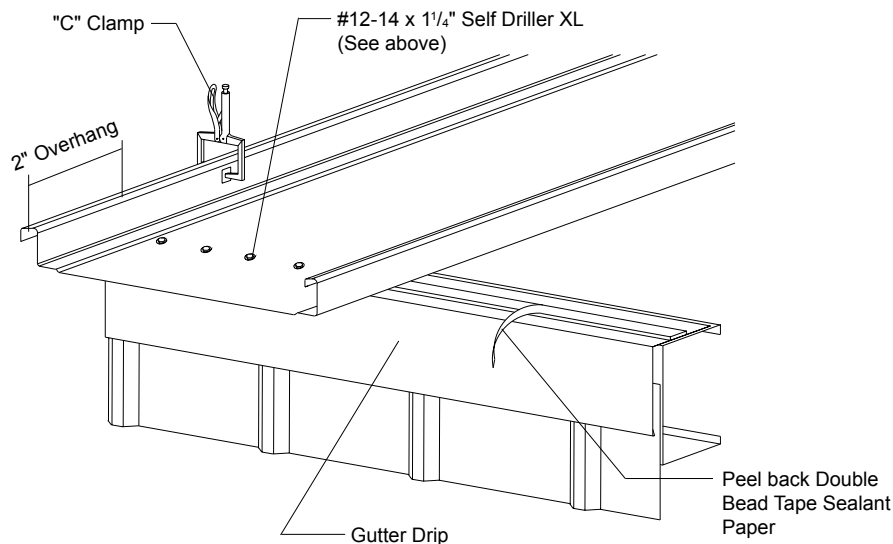

INSTALLING PANEL CLIPS

STEP 4

Note: The following procedures are based on installing panel clips over steel purlins. For fastening clips to a substructure other than steel, (see page 40). Design wind uplift requirements and insulation thickness must be considered for proper selection of clip type, size, and spacing. (See Systems Components chart on page 40.)

Steps:

1. When utilizing a floating clip system, the base of the clip must be aligned with the centering tab.
2. Place the panel clip over the male leg of panel and center the base of the clip with the center of the top flange of the purlin.
3. Rotate the clip to a vertical position so that the base of the clip rests on the top flange of the purlin.
4. Fasten clip to purlin with (2) 1/4"-14 x 1 1/2" Self Driller No Washer screws. Screws must be torqued enough to pull floating base down out of centering tabs.
5. Clips should be installed at all purlin intersections. **Panel clips are not required at eave framing members.**

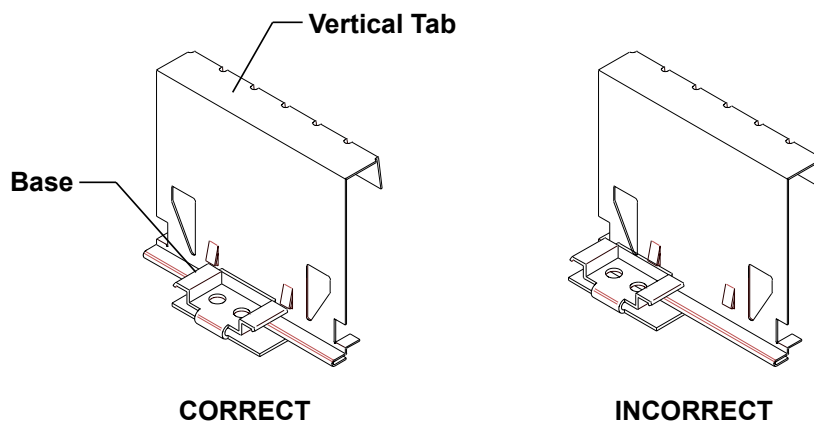

Refer to the chart for determination of the proper clip size. Correct clip size must be used for panel system to function properly.

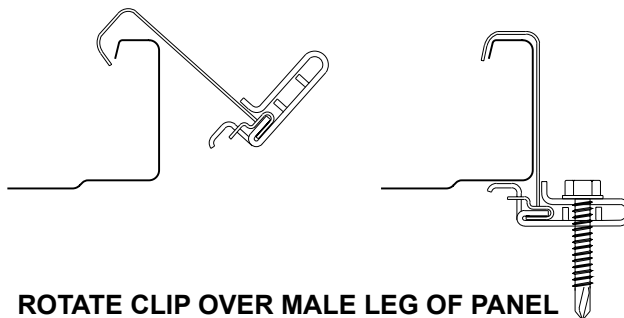

ROTATE CLIP OVER MALE LEG OF PANEL

6. After installing clips along the male leg of the panel, measure across the pan of the panel to confirm panel modularity.
7. If installing over insulation, some method of finding the purlins for clip location must be used. Insulation should be installed as panels are installed allowing for ease of locating purlins.

CAUTION

If a fastener strips out, you must remove the clip and reposition so the fastener can drill a new hole at least 3/8" from the stripped hole or install an oversized fastener in the stripped hole. Failure to do this will result in weakening the roof wind uplift resistance.

ENDLAPPING OF PANEL

STEP 5

Note: It is critical that purlins at the ridge and endlap be exactly located as detailed on erection drawings in order for panels to have adequate movement due to thermal expansion and contraction. Panels with endlaps must be fixed at the eave and endlap splices are to be installed inline along the same purlin. The following procedures also apply to panel runs with multiple laps.

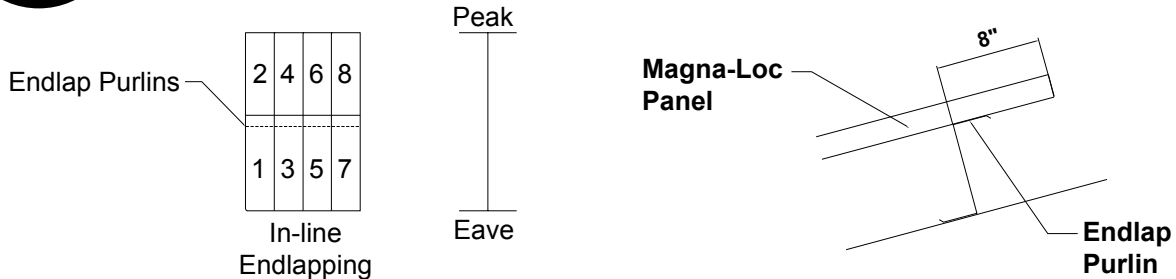

Steps:

1. The eave panel when installed should measure 8" from the web of the endlap purlin to the end of the eave panel. This dimension must be verified. If the panel extends past the web of the endlap purlin by 8", verify that the eave overhang dimension is correct.
2. The male and female legs of the high end of the eave panel are factory notched 2" to allow the peak panel to nest inside the eave panel.
3. Slide Back-up Channel under panel in center of endlap and cee clamp to panel to hold in place for attachment.
4. Apply Endlap Pad on the notched end of the eave panel down male leg, across panel flat, and up the female leg $\frac{1}{2}$ " to $\frac{3}{4}$ " from the end of the panel.
5. Lap the female leg of the peak panel into the female leg of the eave panel lapping the proper 2".
6. Hold the flat of the peak panel up and nest the male legs together.

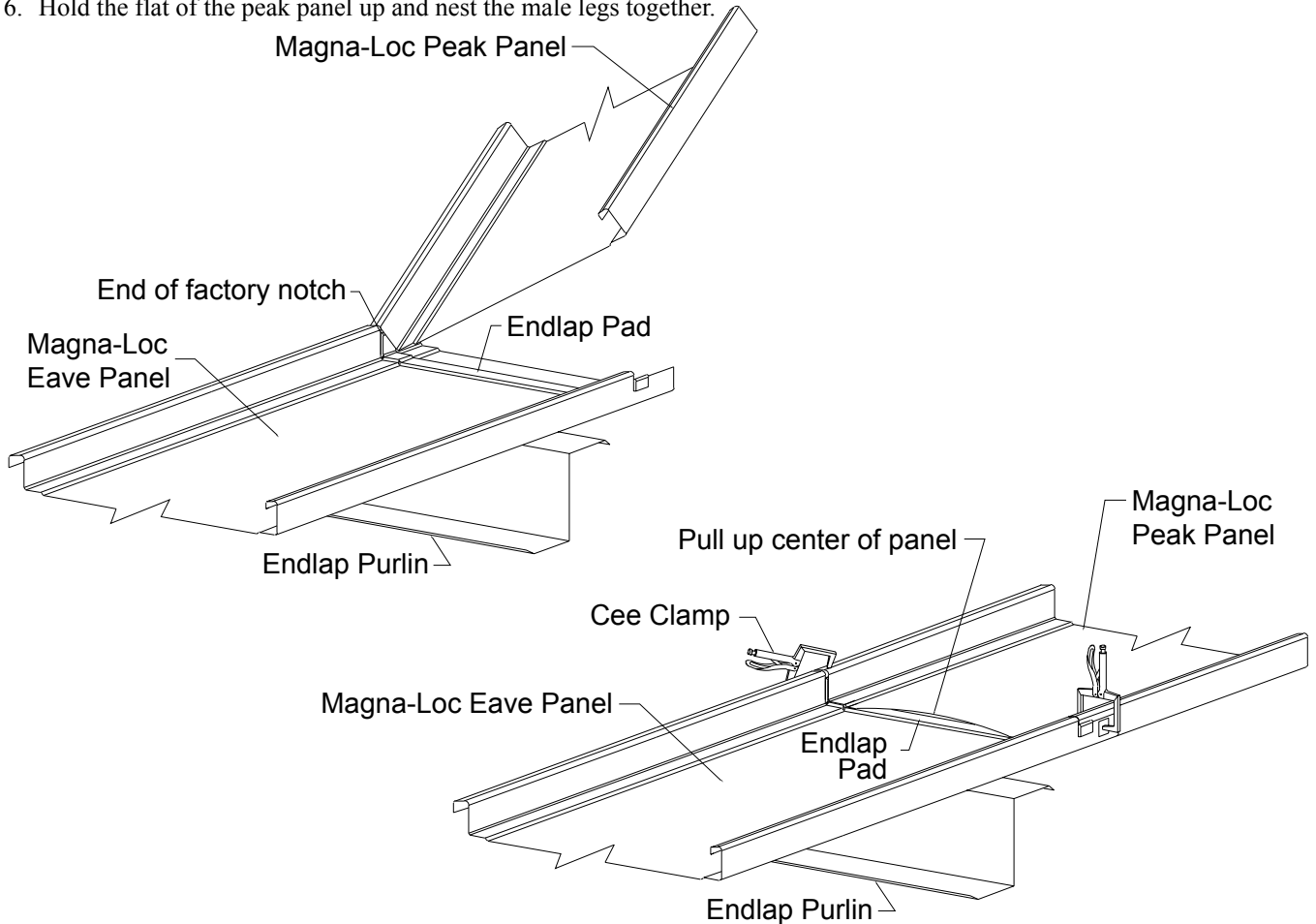

ENDLAPPING OF PANEL (CONT.)

7. Nest the flat of the peak panel into the eave panel.
8. Apply a pig tail of Endlap Pad on the top side of the male leg where panel notch occurs.

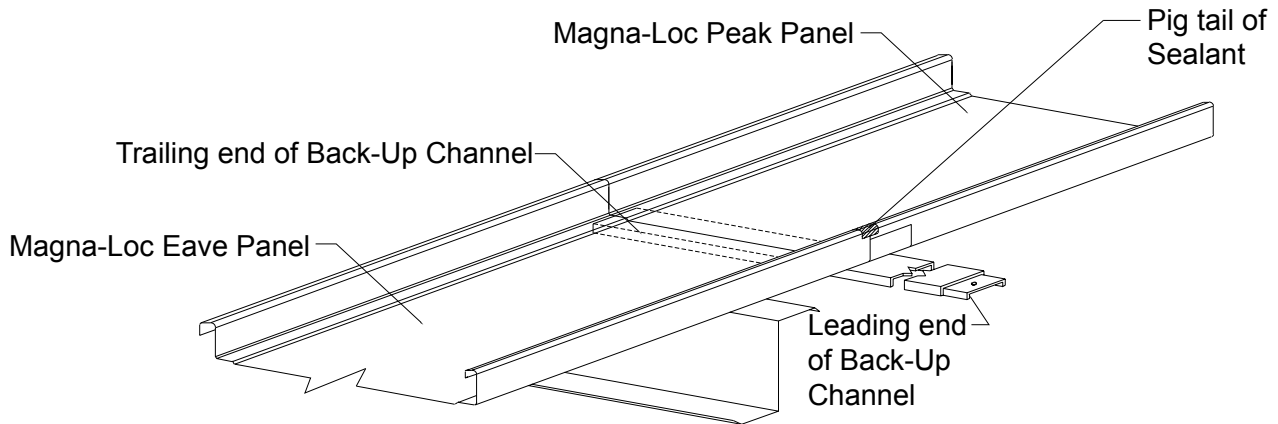

9. Install five (5) #12-14 x 1/4" Self Driller Screws XL where the peak panel laps over the eave panel and fasten in accordance with fastening pattern sequence shown below.
10. Repeat previous steps for subsequent endlaps.

ENDLAPPING SEQUENCE OVERVIEW

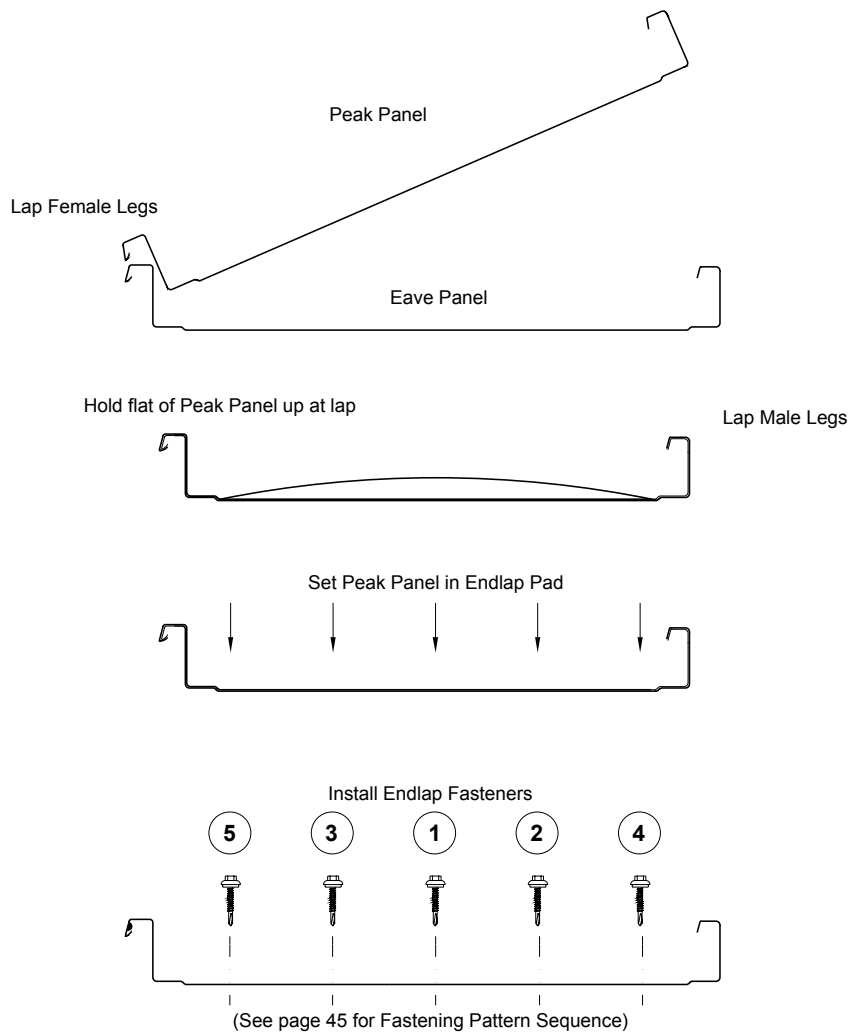

SIDELAPPING OF PANEL

**STEP
6**

Note: It is critical that sealants be properly placed to prevent moisture leakage.

Steps:

1. Apply two $\frac{3}{8}$ " beads of Tube Sealant along the vertical male leg of the panel and across the horizontal portion of the top side of the male leg directly over the Double Bead Tape Sealant on the eave flashing. Be sure the Tube Sealant joins with the Double Bead Tape Sealant.
2. Peel back the paper backing covering the Double Bead Tape Sealant at the eave flashing previously installed.

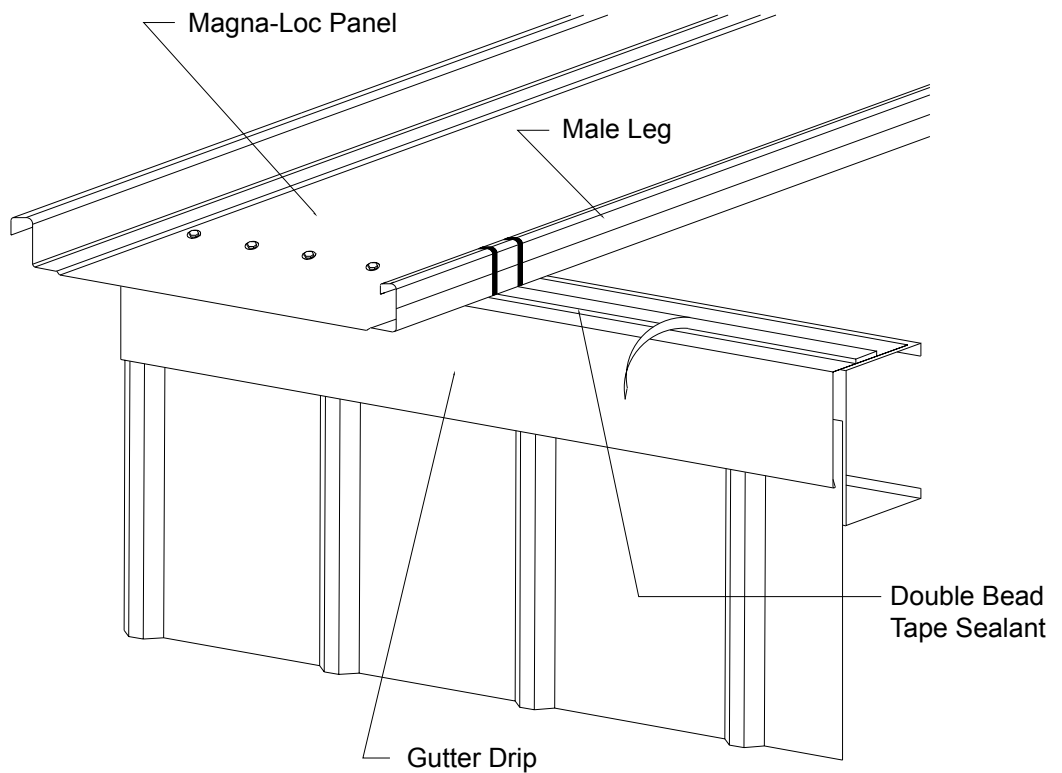
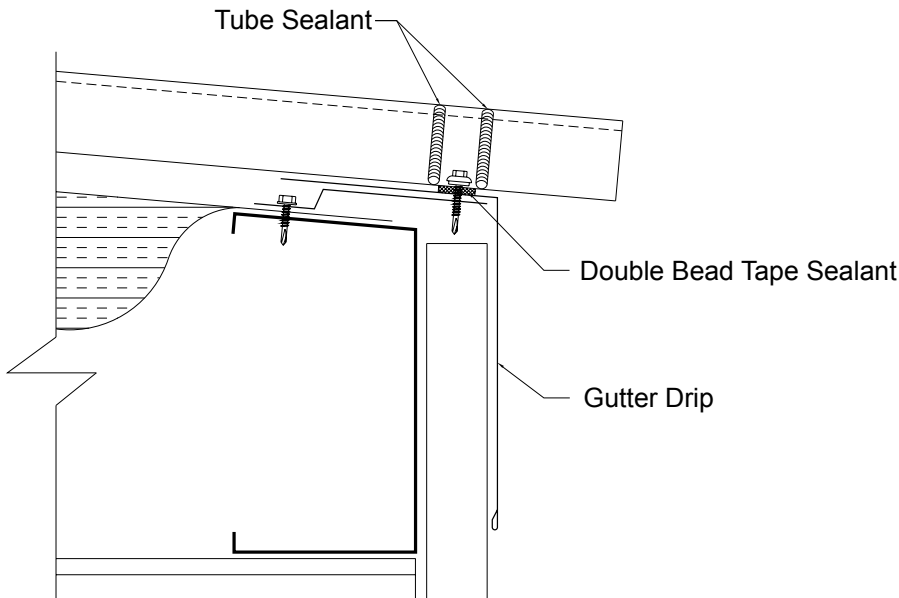

SIDELAPPING OF PANEL (CONT.)

3. Roll the female leg of the second panel into place over the male leg of the first panel so their ends are flush. Do not let the flat of the second panel touch the Double Bead Tape Sealant at the eave until the ends are flush.
4. Use Cee Clamps to hold the two vertical legs of the panel seams together.
5. Install five (5) #12-14 x 1¹/₄" Self Driller XL screws through the panel, tape sealant, eave flashing, and into Eave Plate using the fastening sequence previously shown.

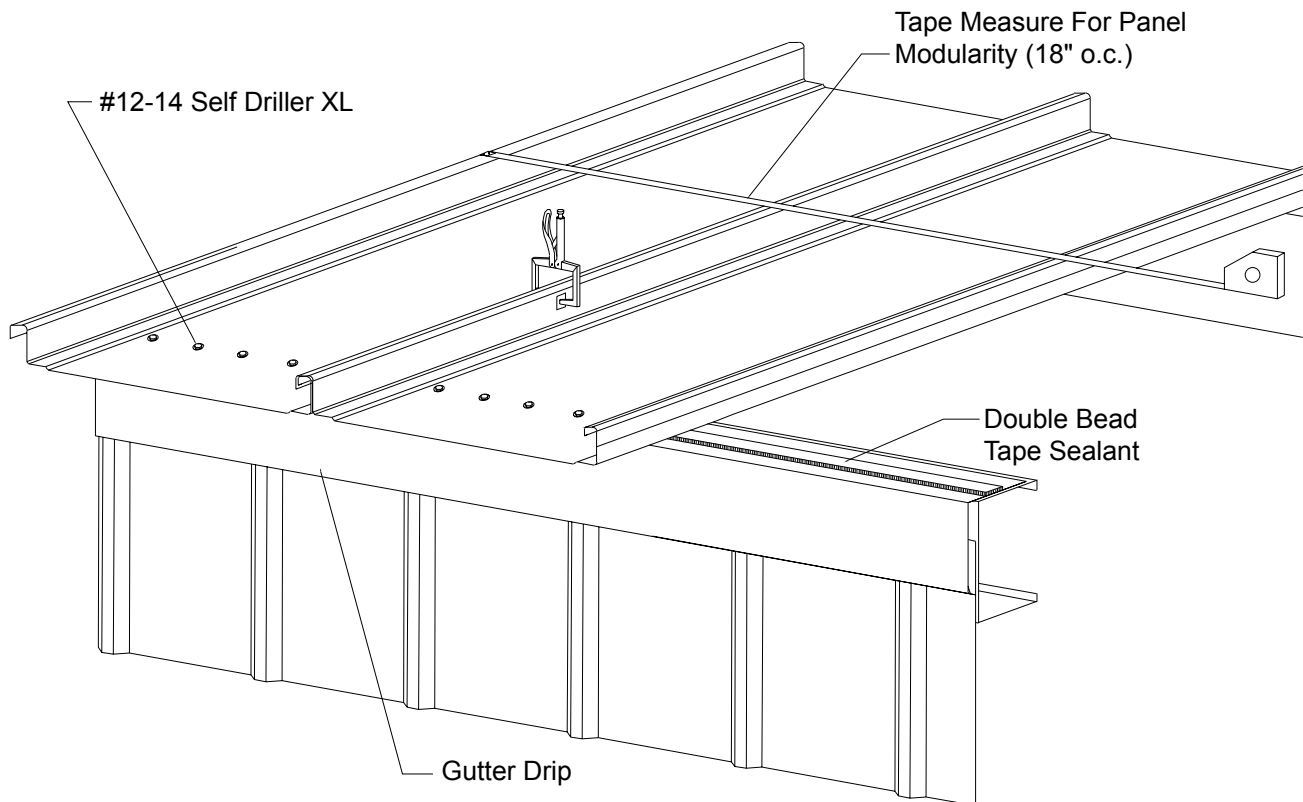

6. Measure the distance from the female leg of the first panel installed. This dimension should be an even multiple of 16"-¹/₄" for every four panels. It is very important that the dimension from the start panel to the last male leg, at the eave and peak, be the same dimension within a ¹/₄" of each other.
7. Make certain that all clips are properly installed and that the panel sidelaps are properly positioned to be seamed. Use the hand crimper to crimp the panel seam at the eave and ridge ends only. This will adequately hold panels in place until fully seamed. Do not hand crimp the panel seam or panel clip at any other locations. Doing so will not allow proper function of electric seamer.

CAUTION

Hand crimping will not fasten the panels together tightly enough to withstand normal wind uplift forces. Be sure to seam all panels as soon as possible. (See seaming panels on pages 31 and 32 for proper seaming instructions.)

TERMINATION OF PANEL

STEP 7

Note: The following steps are for terminating a panel run when the pan width exceeds the width of the building.

Steps:

1. When the roof panel installation has reached the opposite end of the roof, the last panel run may need to be field modified to attach to the Floating Rake Zee previously installed.
2. Measure the distance between the vertical leg of the last full panel run and the vertical leg of the Floating Rake Zee at the eave, endlap, and peak. See dimension "A".
3. Determine if a full panel will fit between the last full run and the Floating Rake Zee. In most cases it will not fit. If the full panel will fit, then continue with the installation of the roof. When the last panel is installed the vertical leg of the male side must fit flush with the Floating Rake Zee.

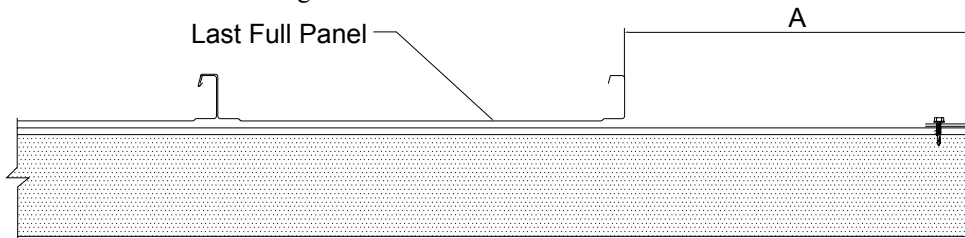

4. If a full panel is too wide to fit between the last full panel run and the Floating Rake Zee, a panel will have to be field cut and bent to simulate a male leg.
5. Use the dimension "A" and mark a line on the last panel to serve as the bend line. Mark a second line 2" past the bend line to be the line you will cut off the excess panel.
6. Field bend the roof panel up 90 degrees to form a vertical leg.
7. Place termination panel between last full panel and vertical leg of Floating Rake Zee making sure the panel fits properly.
8. Clamp termination panel to leg of Floating Rake Zee until Rake Detail is to be installed. (See page 60 for details.)

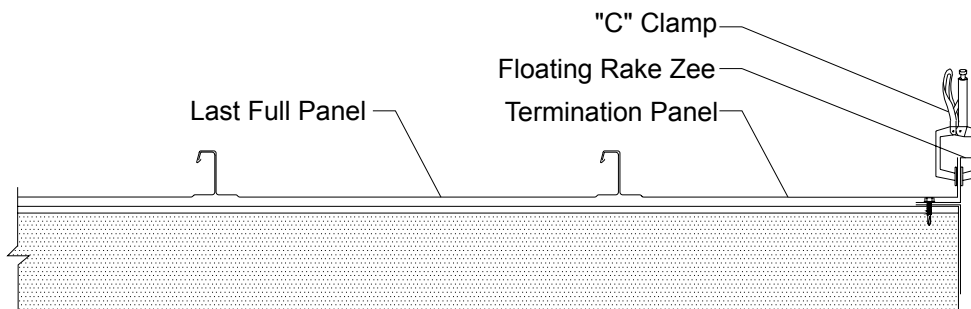
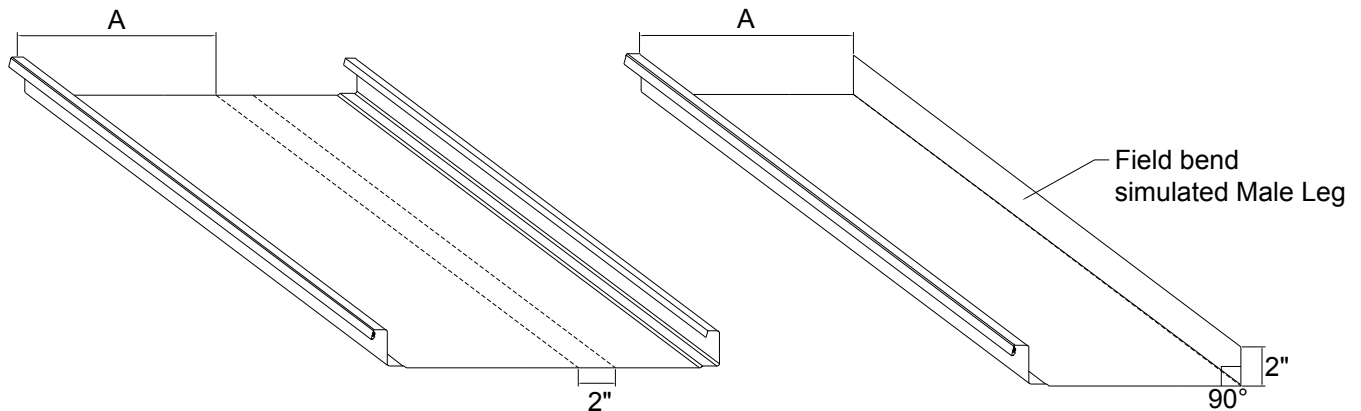

SEAMING PANELS

STEP 8

Note: The Magna-Loc panel system requires the use of a mechanical seamer for proper installation. The mechanical seamer runs from ridge to eave with Magna-Loc panels laid from left to right. This necessary seamer is designed to seam the panel clips and the vertical legs of the panel together for weathertightness and resistance to wind uplift loads.

- Rental or purchase of the Magna-Loc mechanical seamer and hand crimpers for field seaming are the responsibility of the installer. Mechanical seamers and hand crimpers can be acquired from Seamer Tools, Inc. 8265 Highway 178 Olive Branch, MS 38654. Phone No. (662) 895-1222, Fax No. (662) 890-4775.
- Read the field manual that is enclosed in the case with the seamer. The operator should adhere to all instructions for proper use of the seamer. Failure to follow the required instructions may result in damage to the panel and/or seamer. Metal Sales Manufacturing Corporation will not be responsible for damage incurred by improper use of the seamer.
- All panel sidelaps should be seamed with mechanical seamer as soon as possible, after the panels have been installed. Hand crimping the panel sidelaps 8" at the eave, endlap, and ridge locations of the panel will help keep the panels in place during normal erection, but will not prevent the panels from being blown off the roof by moderate strong winds. **Do not hand crimp panel at any clips or locations other than the ridge, endlap, and eave locations.**
- At endlap conditions, panels must be hand-crimped only. Mechanical seaming of panels will cause rib distortion due to multiple thicknesses along the endlap.
- Run sufficient power to the roof to operate the seamer. If the job site is a long distance from the roof or if the roof is large, consider using a portable generator placed on the roof near the seam.
- Do not overload or damage the roof with the generator unit. Be sure to follow OSHA and local electrical codes when installing generator.
- Prior to seaming panels check all seams making sure they are properly engaged. All dirt, debris, and excess sealant should be removed from flat part of panel and seams.

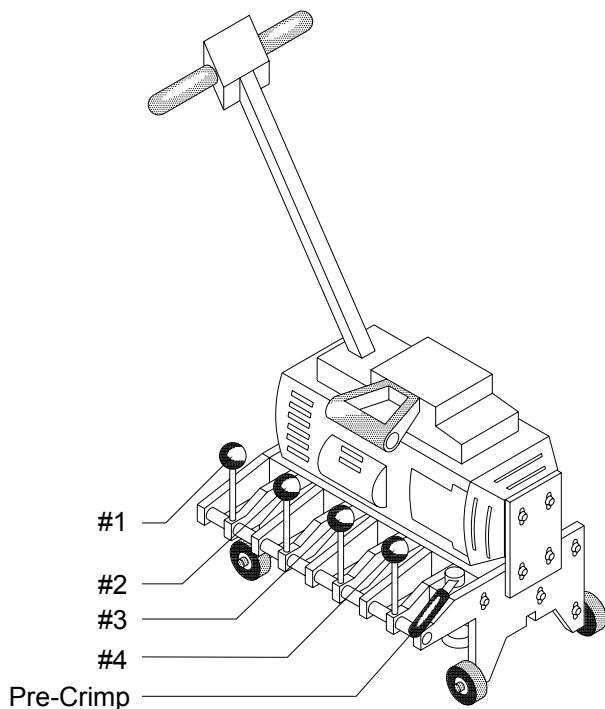

MECHANICAL SEAMER

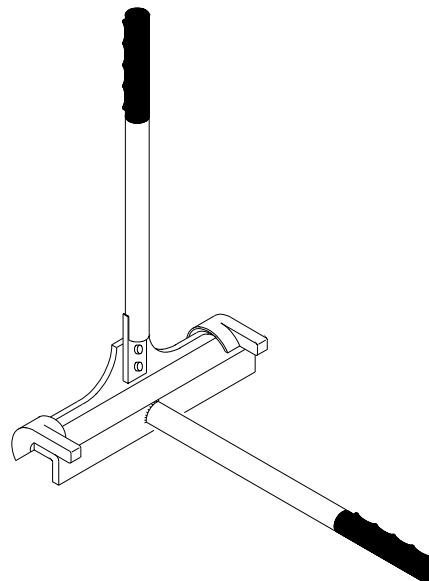

HAND CRIMPER

SEAMING PANELS (CONT.)

Note: When panels are installed from left to right, electric seamer operates from ridge to eave.

Steps:

1. To start seaming, hand crimp first 8" of seam at eave, endlap, and ridge locations only. **Do not hand crimp at clip locations.**

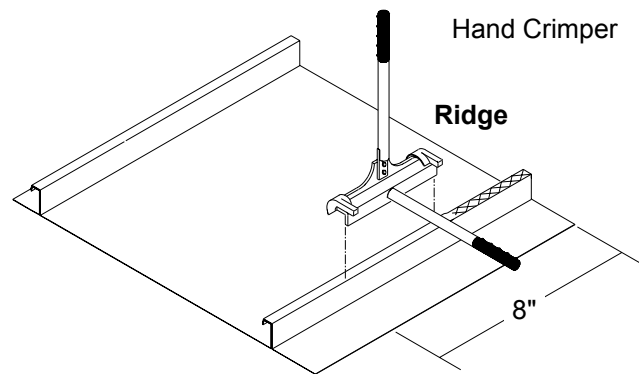
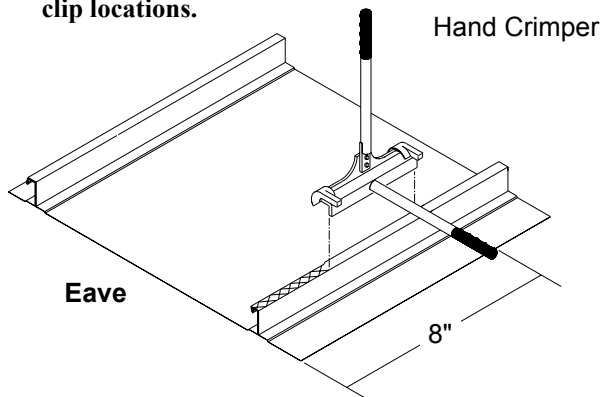

2. Position mechanical seamer over hand crimped roof seam at ridge location so that the levers are on the same side of the seam that is to be crimped by the mechanical seamer.

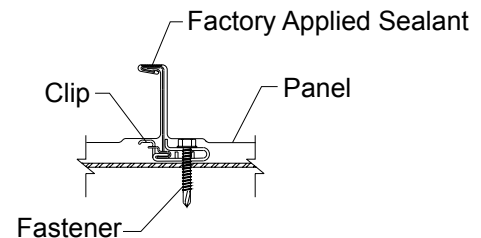
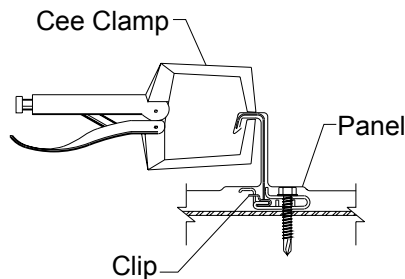

3. Engage roller levers in the following order: #1, #2, #3, #4, and then the roller lever (see page 52-53). Pre-crimp lever may need to be held down to avoid scratching of panel.

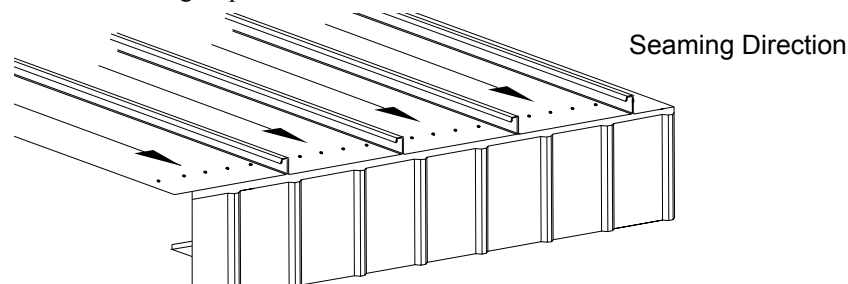

4. Prior to running seamer, check to make sure that Magna-Loc panels are fully engaged along the entire run of the panel. Small c-clamps may be required on the horizontal portion of the seam to hold panel seam engaged while seaming.
5. Turn on the power to seamer and walk with the seamer as it seams the panel. Stop the seamer in the first few feet to ensure proper seam is being achieved. Turn the mechanical seamer off before the hand crimped endlap or eave portion of the panel. If Magna-Loc roof panels have been endlapped, mechanical seamer must be stopped, moved, and restarted over the hand crimped area of the endlap. Remaining seam between hand crimped portion and mechanically seamed portion may have to be hand crimped for continuous tight seam.
6. At the end of the first run, remove mechanical seamer and return to step #1 for remaining panels.
7. At completion of seaming, repack tool and return to Seamer Tools, Inc. 8265 Highway 178 Olive Branch, MS 38654. Phone No. (662) 895-1222, Fax No. (662) 890-4775.

CAUTION

Do not run the seamer off the end of the panel. If the seamer is run off the end of the roof it could cause injury to personnel and damage the roof or the seamer. (See seamer instructions enclosed in the case for additional information about the proper handling of the seamer.)

**1/2:12 Slope
Minimum**

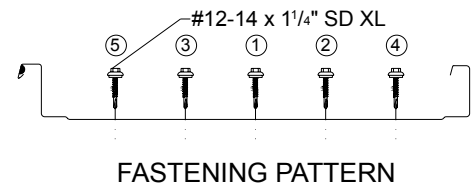
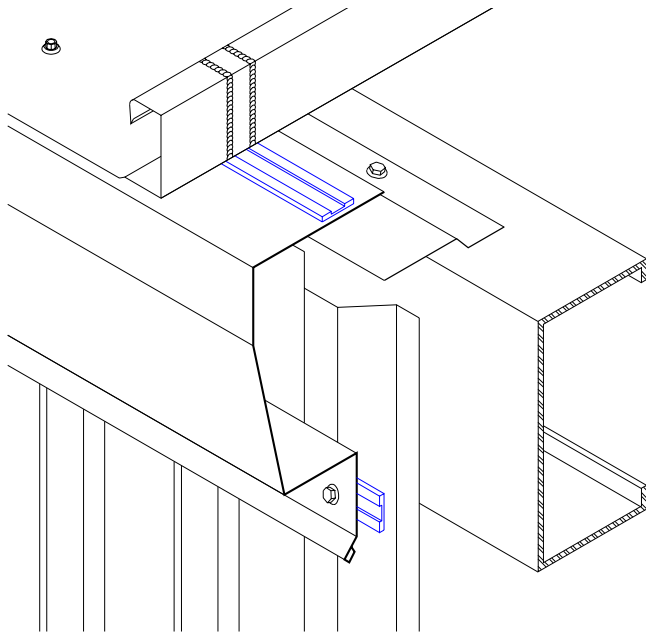
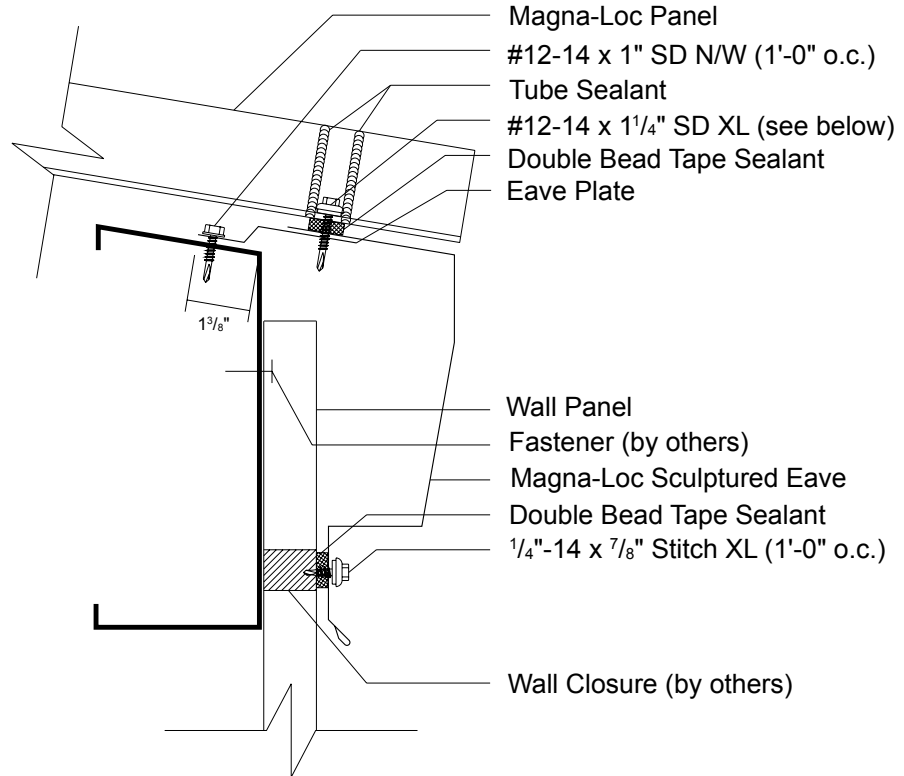

INSTALLATION NOTES

All Eave flashings must be installed prior to panel installation.

1. Install Sculptured Eave back against previously installed Eave Plate, (see page 44 for Eave Plate installation). To hold Sculptured Eave in place fasten to substrate with #10-16 x 1" Pancake Head fastener, 4'-0" o.c.
2. Fasten Sculptured Eave to wall with appropriate fastener, 12" o.c.
3. Apply a row of Double Bead Tape Sealant across Sculptured Eave so that sealant is centered over top leg of Eave Plate.
4. If two or more flashings are required, lap the flashing over the previously installed flashing by a minimum of 2" placing a bead of Tube Sealant between the flashings and securing with Pop Rivets, 2.5" o.c.
5. Once panels have been installed and properly sealed, (See page 45), fasten through panel, Double Bead Tape Sealant, and Sculptured Eave into Eave Plate with (5) #12-14 x 1/4" Self Driller XL screws per panel.

**1/2:12 Slope
Minimum**

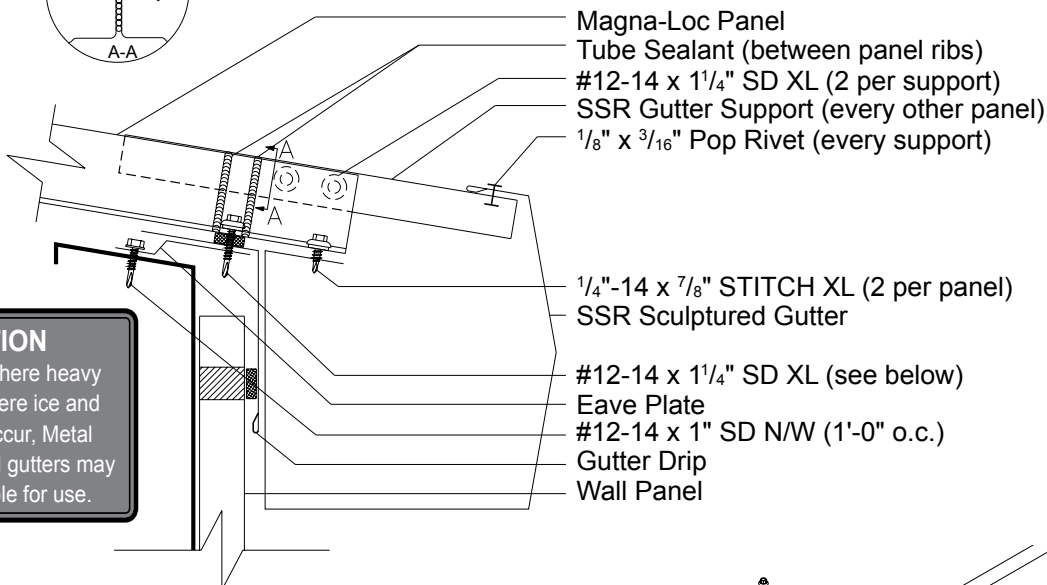
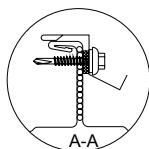

CAUTION
 In locations where heavy rainfall or severe ice and snow may occur, Metal Sales' standard gutters may not be suitable for use.

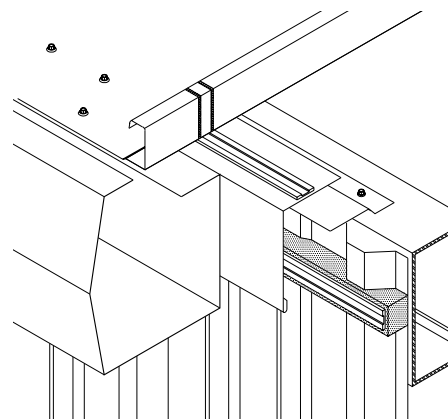
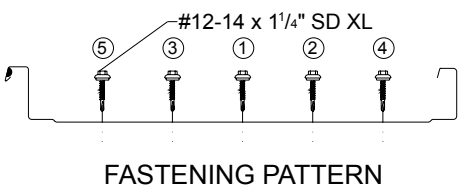

INSTALLATION NOTES

Gutter Drip Flashings must be installed prior to panel installation.

1. Install Gutter Drip back against previously installed Eave Plate, (see page 44 for Eave Plate installation). To hold Gutter Drip in place fasten to substrate with #10-16 x 1" Pancake Head fastener, 4'-0" o.c.
2. Apply a row of Double Bead Tape Sealant across Gutter Drip so that sealant is centered over top leg of Eave Plate.
3. If two or more flashings are required, lap the flashing over the previously installed flashing by a minimum of 2" placing a bead of Tube Sealant between the flashings and securing with Pop Rivets, 2.5" o.c.
4. Once panels have been installed and properly sealed, (see page 45), fasten through panel, Double Bead Tape Sealant, and Gutter Drip into Eave Plate with (5) #12-14 x 1 1/4" Self Driller XL screws per panel.
5. Attach the SSR Gutter Support to the panel rib every other panel (32" or 36" o.c.) with (2) #12-14 x 1 1/4" Self Driller XL screws. Fasteners must be applied down slope of the sealant line. Do not apply screws up slope of the sealant line. The SSR Gutter Supports can be adjusted in or out to allow the gutter to be installed in a straight line, even if the edge of the roof is not straight.
6. Prepare the first gutter section with a Sculptured Gutter End. Consider rake to gutter connection for proper placement of Sculptured Gutter End and the gutter flashing. Fasten with (8) 1/4"-14x7/8" Stitch XL screws or Pop Rivets.
7. Position the gutter over the SSR Gutter Supports with one end against the Rake flashing and rotate gutter into position.
8. Clamp the top of the back lip of the gutter in position with a C-clamp. Install a #1/4-14 x 7/8" Stitch XL screw or Pop Rivet where the front lip of the gutter rests on the SSR Gutter Support, and fasten the back lip of the gutter to the panel flat with (2) 1/4"-14 x 7/8" Stitch XL screw per panel.
9. Field miter the rake trim to fit the gutter contour at the corner of the building or install a SSR Sculptured Corner Box.
10. If two or more flashings are required, lap the flashing over the previously installed flashing by a minimum of 2" placing a bead of Tube Sealant between the flashings and securing with 1/4"-14 x 7/8" Stitch XL screws or Pop Rivets, 2.5" o.c.

**3:12 Slope
Minimum**

- Magna-Loc Panel (field cut)
- (2) Rows of Tube Sealant (between panel ribs)
- #12-14 x 1 1/4" SD XL (see page 45)
- Double Bead Tape Sealant
- Eave Plate
- #12-14 x 1" SD NW (1'-0" o.c.)
- SSR 4.5" Drop Valley
- Valley Plate (by others)

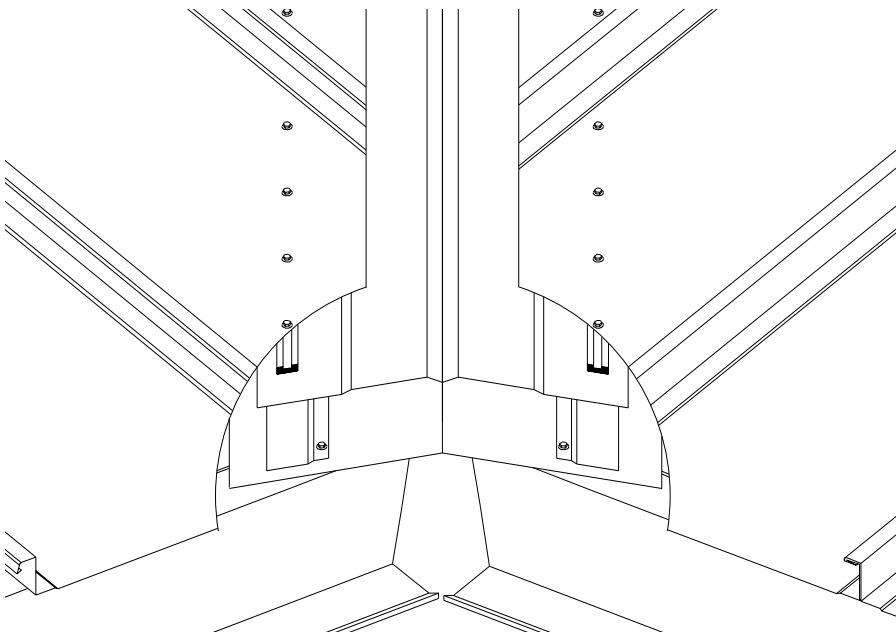
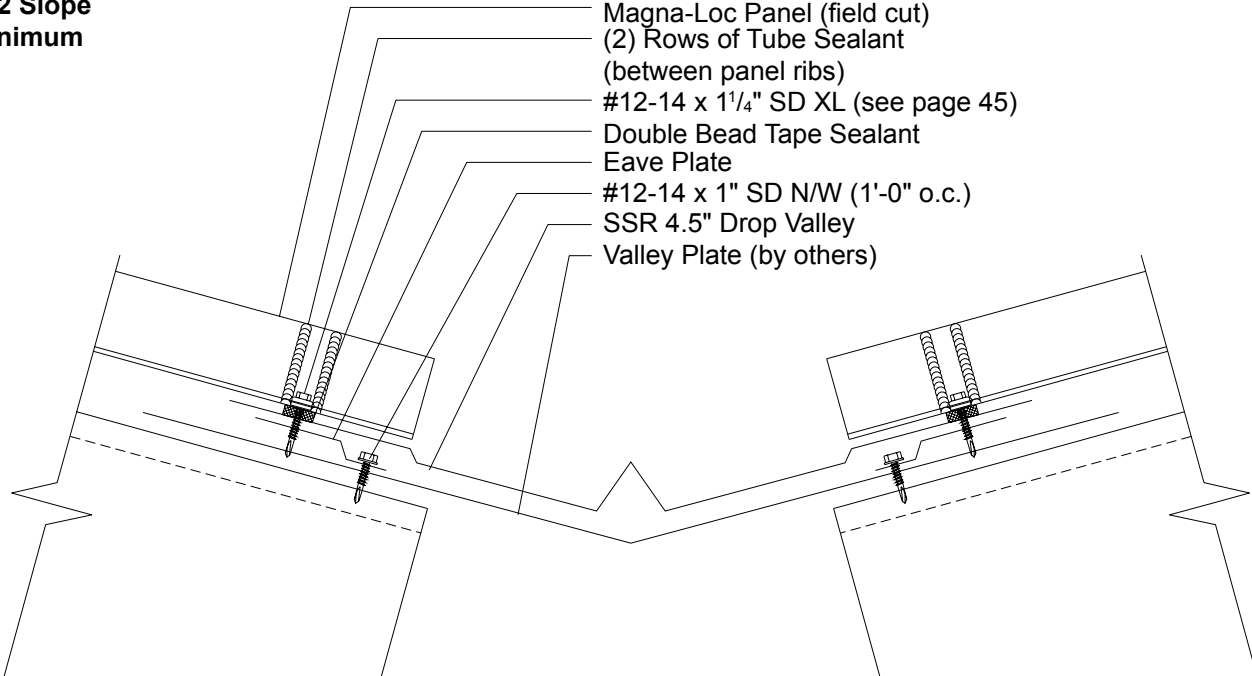

INSTALLATION NOTES

All Valley flashings must be installed prior to panel installation. If two or more Valley flashings are required, valley must be installed working from eave to peak. It is recommended that ice and water shield be installed under Valley flashing for added moisture protection.

1. Install Drop Valley flashing back against previously installed Eave Plates. To hold Sculptured Eave in place fasten to substrate with #10-16 x 1" Pancake Head fastener, 4'-0" o.c. into top leg of Eave Plate.
2. Apply a row of Double Bead Tape Sealant across both sides of Drop Valley flashing so that sealant is centered over top leg of Eave Plate.
3. If two or more flashings are required, lap the flashing over the previously installed flashing by a minimum of 6" placing two beads of Tube Sealant per side between the flashings.
4. Once panels have been installed and properly sealed, (see page 45), fasten through panel, Double Bead Tape Sealant, and Drop Valley into Eave Plate with #12-14 x 1 1/4" Self Driller XL screws.

**3:12 Slope
Minimum**

- Magna-Loc Panel (field cut)
- (2) Rows of Tube Sealant (between panel ribs)
- #12-14 x 1 1/4" SD XL (see page 45)
- Double Bead Tape Sealant
- Eave Plate
- #12-14 x 1" SD N/W (1'-0" o.c.)
- SSR 9" Drop Valley
- Valley Plate (by others)

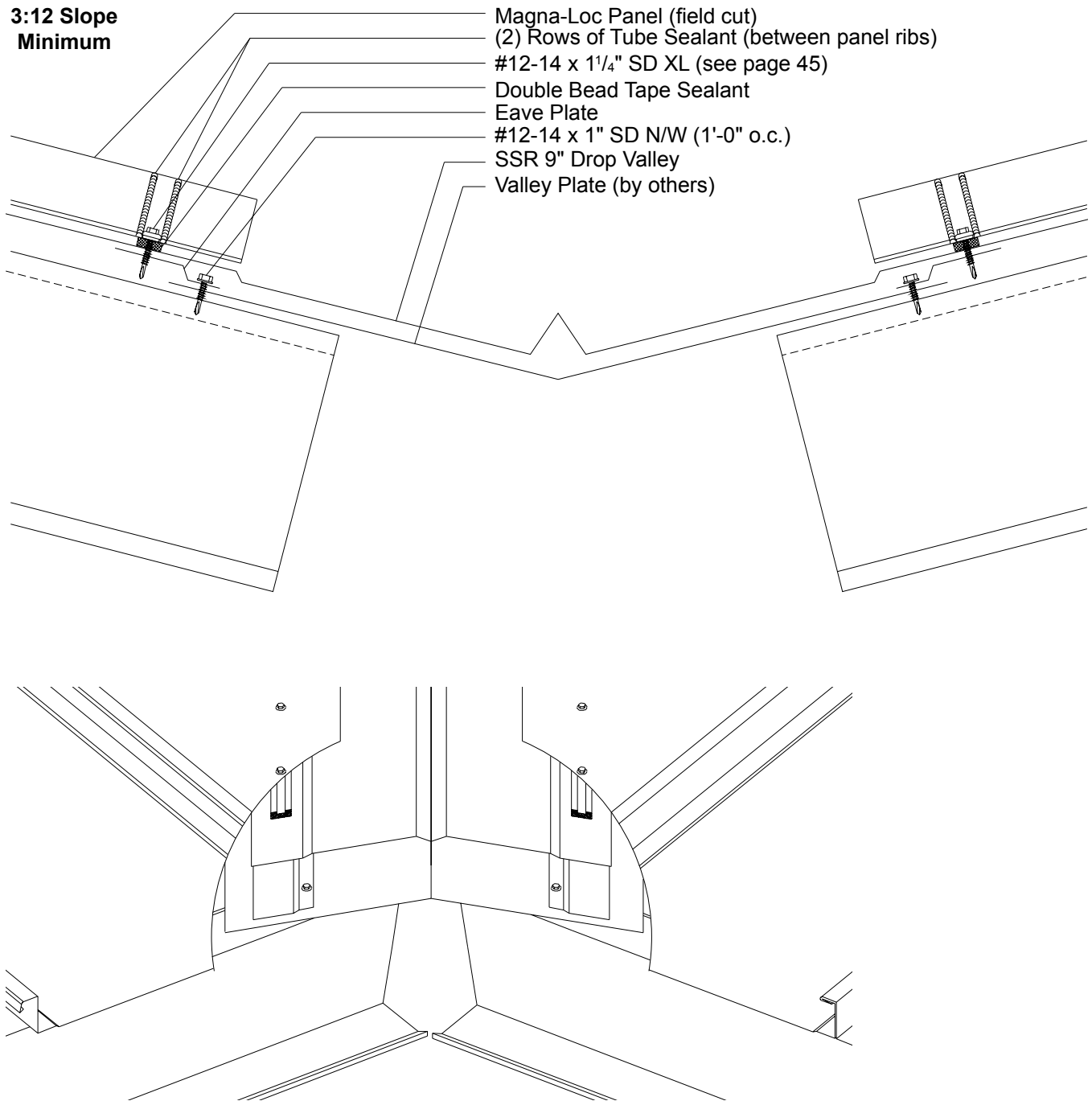

INSTALLATION NOTES

All Valley flashings must be installed prior to panel installation. If two or more Valley flashings are required, valley must be installed working from eave to peak. It is recommended that ice and water shield be installed under Valley flashing for added moisture protection.

1. Install Drop Valley flashing back against previously installed Eave Plates, (see page 44). To hold Sculptured Eave in place fasten to substrate with #10-16 x 1" Pancake Head fastener, 4'-0" o.c. into top leg of Eave Plate.
2. Apply a row of Double Bead Tape Sealant across both sides of the Drop Valley flashing so that the sealant is centered over the top leg of the Eave Plate.
3. If two or more flashings are required, lap the flashing over the previously installed flashing by a minimum of 6" placing two beads of Tube Sealant per side between the flashings.
4. Once panels have been installed and properly sealed, (see page 45), fasten through panel, Double Bead Tape Sealant, and Drop Valley into Eave Plate with #12-14 x 1 1/4" Self Driller XL screws.

**1/2:12 Slope
Minimum**

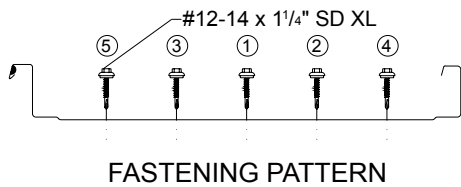
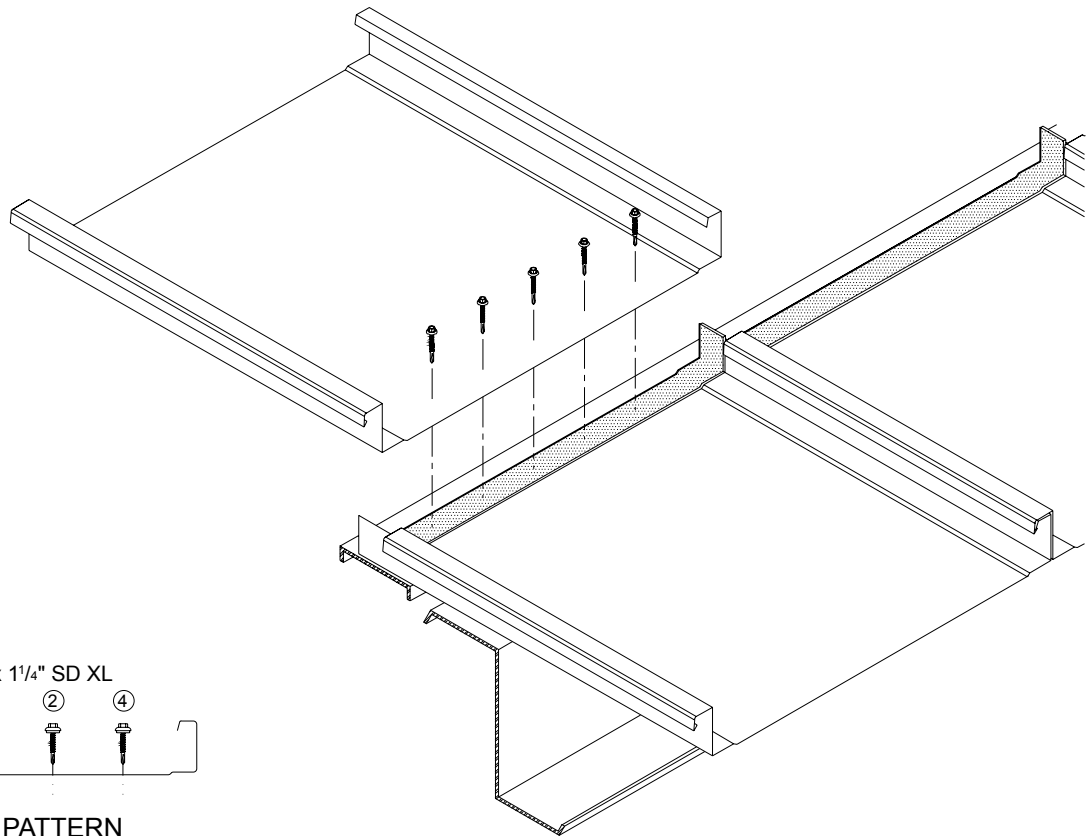
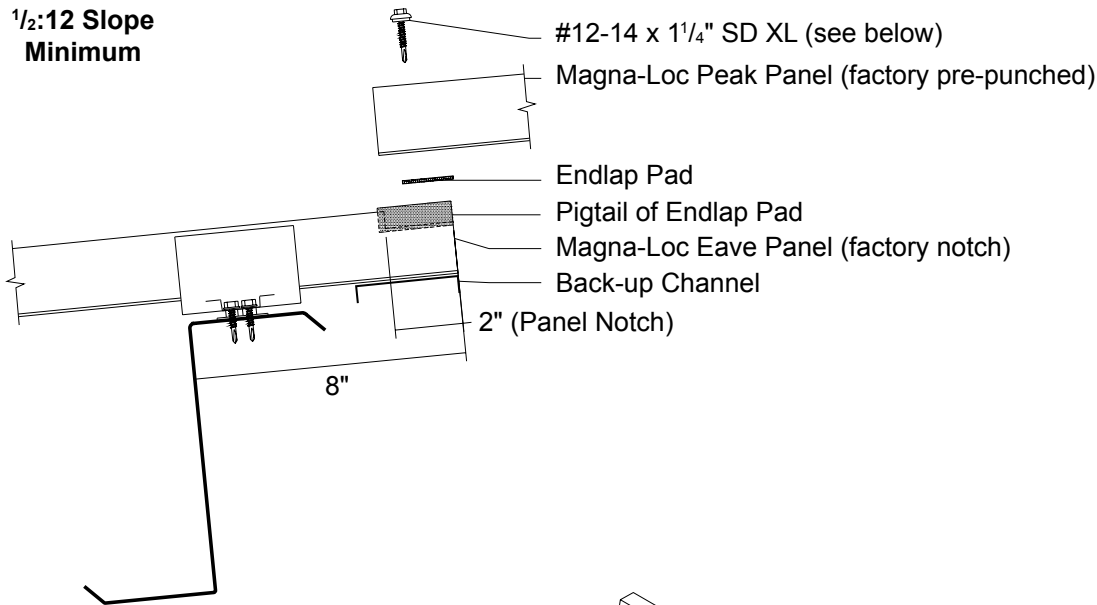

INSTALLATION NOTES

1. Once eave panel has been installed, (see page 47), slide a Back-Up Channel under upper edge of panels. Back-Up Channel should be flush with edge of Magna-Loc eave panel. Use C-clamps to hold Back-Up Channel in place.
2. Apply a row of Endlap Pads across flat pans, up and over all ribs of eave panels. Endlap Pad should be flush with edge of eave panel.
3. Roll Magna-Loc peak panel into place and nest with eave panel so that 2" factory notch is completely covered. (See page 47 for complete details on installing lapped panels.)
4. With peak panel in place, fasten panel endlap with (5) #12-14 x 1 1/4" SD XL fasteners per panel through factory punched holes and into the Back-Up Channel.
5. Apply a pig tail of Endlap Pad, approximately 2 1/2", over factory notched section of male legs.

**1/2:12 Slope
Minimum**

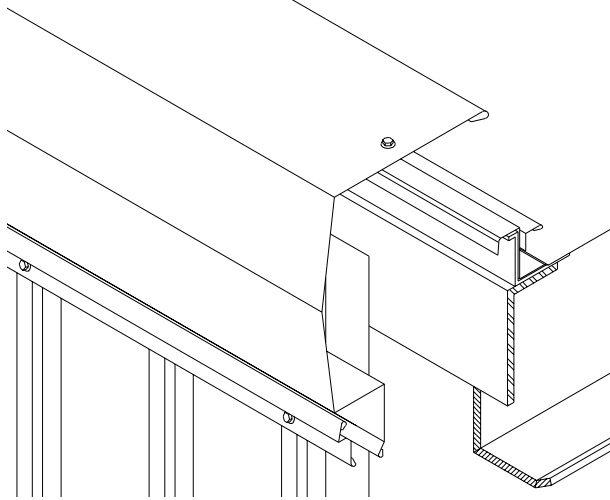
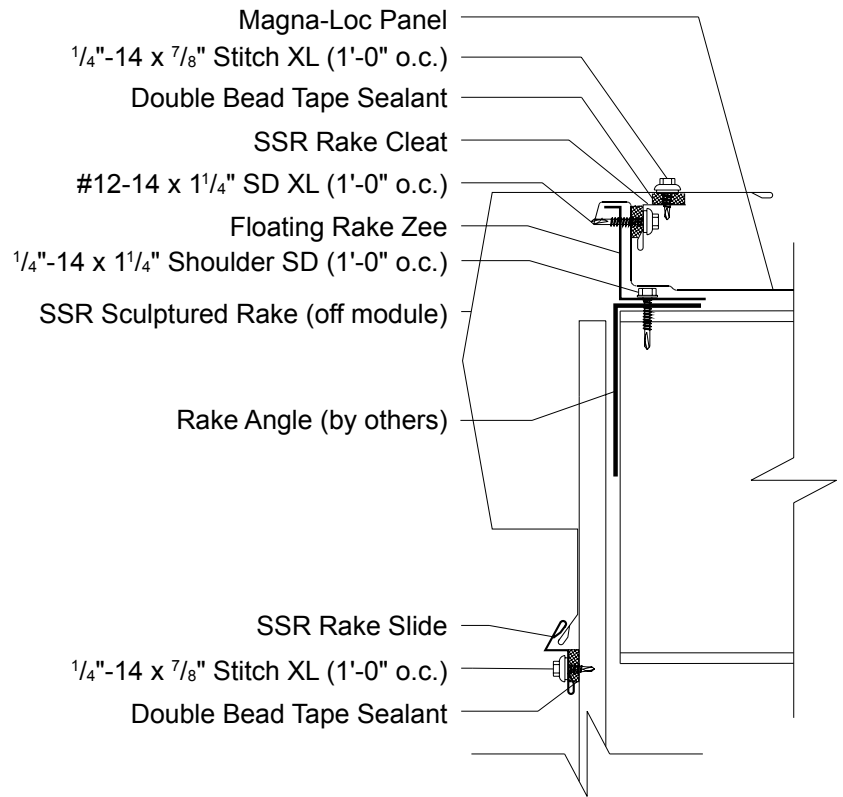

INSTALLATION NOTES

Magna-Loc floating rake zee and Magna-Loc panels must be installed prior to SSR Sculptured Rake installation (See pages 43-53).

1. With Magna-Loc panel properly nested over top of Magna-Loc Floating Rake Zee, apply a row of Double Bead Tape Sealant across upper side of panel rib.
2. Install SSR Rake Cleat over Double Bead Tape Sealant. Fasten through SSR Rake Cleat, Tape Sealant, panel, and into Floating Rake Zee with #12-14 x 1 1/4" Self Driller XL screws, 1'-0" o.c.
3. Apply a row of Double Bead Tape Sealant across top leg of SSR Rake Cleat.
4. Install SSR Sculptured Rake flashing so that top of flashing is flush with top of SSR Rake Cleat and panel rib. Fasten through SSR Sculptured Rake, Tape Sealant, and into SSR Rake Cleat with 1/4"-14 x 7/8" Stitch XL, 1'-0" o.c.
5. Position and apply a row of Double Bead Tape Sealant across wall panel just below lower leg of SSR Rake Flashing.
6. Install SSR Rake Slide over lower leg of SSR Rake flashing and Double Bead Tape Sealant. Fasten with 1/4"-14 x 7/8" Stitch XL, 1'-0" o.c.
7. If two or more flashings are required, lap the flashing over the previously installed flashing by a minimum of 2" placing a bead of Tube Sealant between the flashings and securing with Pop Rivets, 2.5" o.c.

**1/2:12 Slope
Minimum**

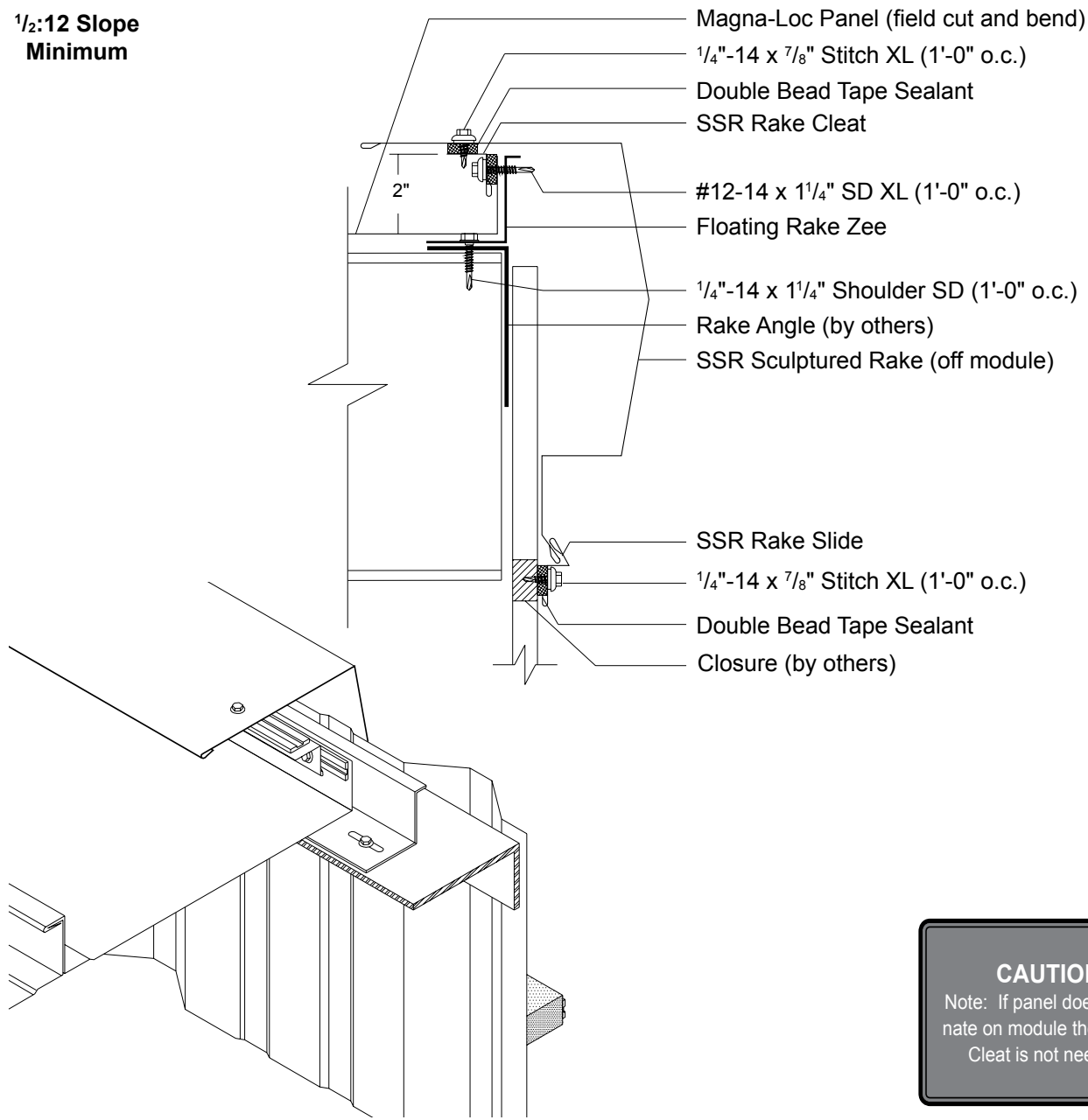

CAUTION
Note: If panel does terminate on module then Rake Cleat is not needed.

INSTALLATION NOTES

Magna-Loc Floating Rake Zee and Magna-Loc panels must be installed prior to SSR Sculptured Rake installation (See Pages 43-53).

1. With Magna-Loc panel nested against Magna-Loc Floating Rake Zee, apply a row of Double Bead Tape sealant across upper side of field bent panel rib. (See page 51 for proper bending of panel.)
2. Install SSR Rake Cleat over Double Bead Tape Sealant. Fasten through SSR Rake Cleat, Tape Sealant, panel, and into Floating Rake Zee with #12-14 x 1 1/4" Self Driller XL screws, 1'-0" o.c.
3. Apply a row of Double Bead Tape Sealant across top leg of SSR Rake Cleat.
4. Install SSR Sculptured Rake flashing so that top of flashing is flush with top of SSR Rake Cleat and panel rib. Fasten through SSR Sculptured Rake, Tape Sealant, and into SSR Rake Cleat with 1/4"-14 x 7/8" Stitch XL, 1'-0" o.c.
5. Position and apply a row of Double Bead Tape Sealant across wall panel just below lower leg of SSR Rake flashing.
6. Install SSR Rake Slide over lower leg of SSR Rake flashing and Double Bead Tape Sealant. Fasten with 1/4"-14 x 7/8" Stitch XL, 1'-0" o.c.
7. If two or more flashings are required, lap the flashing over the previously installed flashing by a minimum of 2" placing a bead of Tube Sealant between the flashings and securing with Pop Rivets, 2.5" o.c.

**1/2:12 Slope
Minimum**

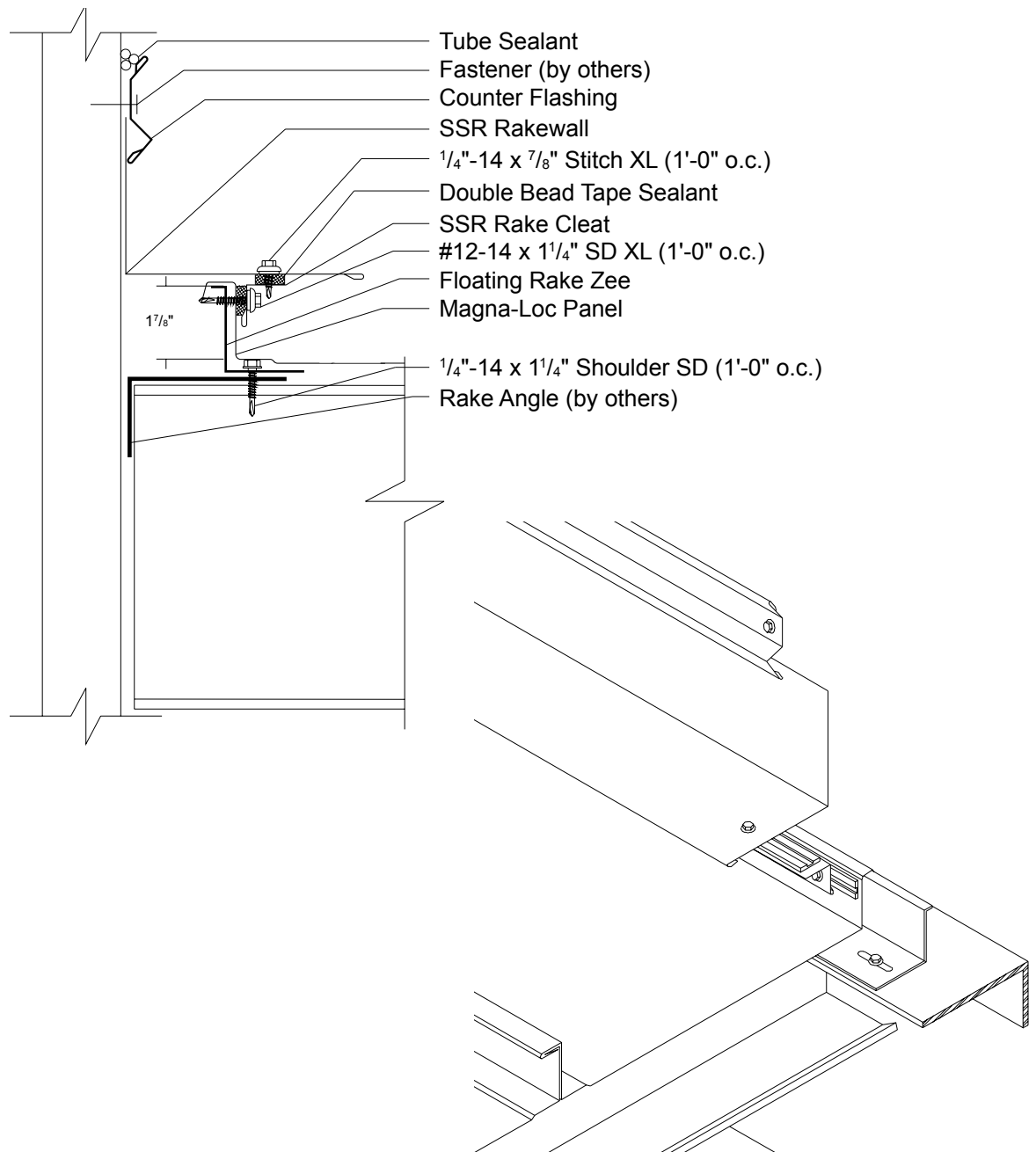

INSTALLATION NOTES

Magna-Loc Floating Rake Zee and Magna-Loc Panels must be installed prior to Rake wall installation (See pages 43-53).

1. With Magna-Loc panel properly nested over top of Magna-Loc Floating Rake Zee, apply a row of Double Bead Tape Sealant across upper side of panel rib.
2. Install SSR Rake Cleat over Double Bead Tape Sealant. Fasten through SSR Rake Cleat, Tape Sealant, panel, and into Floating Rake Zee with #12-14 x 1 1/4" Self Driller XL screws, 1'-0" o.c.
3. Apply a row of Double Bead Tape Sealant across top leg of SSR Rake Cleat.
4. Install SSR Rake Wall so that top of flashing is flush with top of SSR Rake Cleat and panel rib. Fasten through SSR Rake Wall, Tape Sealant, and into SSR Rake Cleat with 1/4"-14 x 7/8" Stitch XL, 1'-0" o.c.
5. Install Counter Flashing, Reglet, or wall panel and fasten to parapet wall with appropriate fastener, 12" o.c. If Counter Flashing or Reglet is used, seal to parapet wall with Tube Sealant. Do NOT fasten SSR Rake Wall to parapet wall.
6. If two or more flashings are required, lap the flashing over the previously installed flashing by a minimum of 2" placing a bead of Tube Sealant between the flashings and securing with Pop Rivets, 2.5" o.c.

**1/2:12 Slope
Minimum**

- Tube Sealant
- Reglet Flashing
- SSR Rakewall
- Floating Rake Zee
- 1/4"-14 x 7/8" Stitch XL (1'-0" o.c.)
- Double Bead Tape Sealant
- #12-14 x 1 1/4" SD XL (1'-0" o.c.)
- SSR Rake Cleat
- 1/4"-14 x 1 1/4" Shoulder SD (1'-0" o.c.)
- Magna-Loc Panel (field cut and bend)
- Rake Angle (by others)

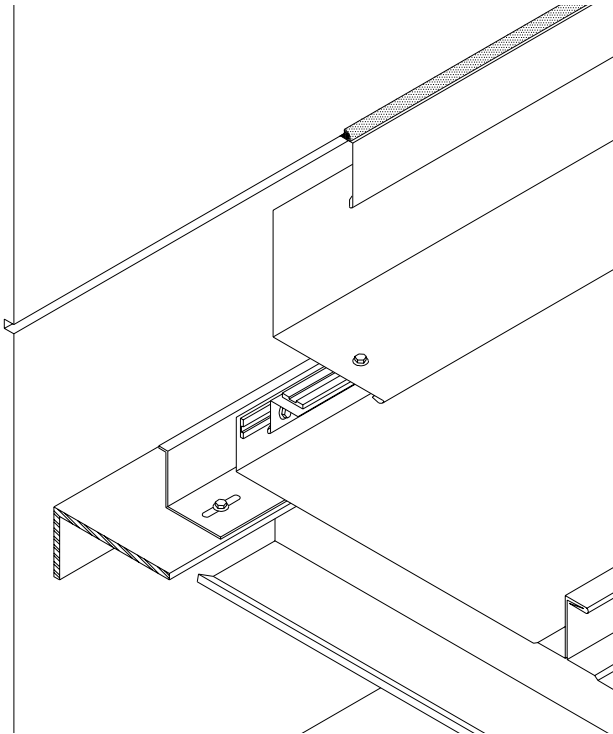
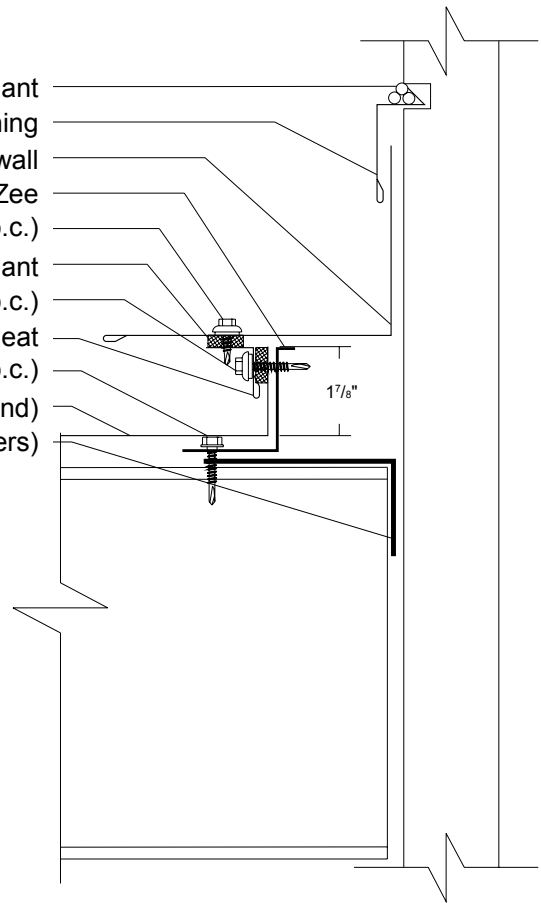

INSTALLATION NOTES

Magna-Loc Floating Rake Zee and Magna-Loc Panels must be installed prior to Rakewall installation (See pages 43-53).

1. With Magna-Loc panel nested against Magna-Loc Floating Rake Zee, apply a row of Double Bead Tape Sealant across upper side of field bent panel rib. (See page 51 for proper bending of panel.)
2. Install SSR Rake Cleat over Double Bead Tape Sealant. Fasten through SSR Rake Cleat, tape sealant, panel, and into floating rake zee with #12-14 x 1 1/4" Self Driller XL screws, 1'-0" o.c.
3. Apply a row of Double Bead Tape Sealant across top leg of SSR Rake Cleat.
4. Install SSR Rakewall so that top of flashing is flush with top of SSR Rake Cleat and panel rib. Fasten through SSR Rakewall, tape sealant, and into SSR Rake Cleat with 1/4"-14 x 7/8" Stitch XL, 1'-0" o.c.
5. Install Counter Flashing, Reglet, or wall panel and fasten to parapet wall with appropriate fastener, 12" o.c. If Counter Flashing or Reglet is used, seal to parapet wall with tube sealant. Do NOT fasten SSR Rakewall to parapet wall.
6. If two or more flashings are required, lap the flashing over the previously installed flashing by a min. of 2" placing a bead of Tube Sealant between the flashings and securing with Pop Rivets, 2.5" o.c.

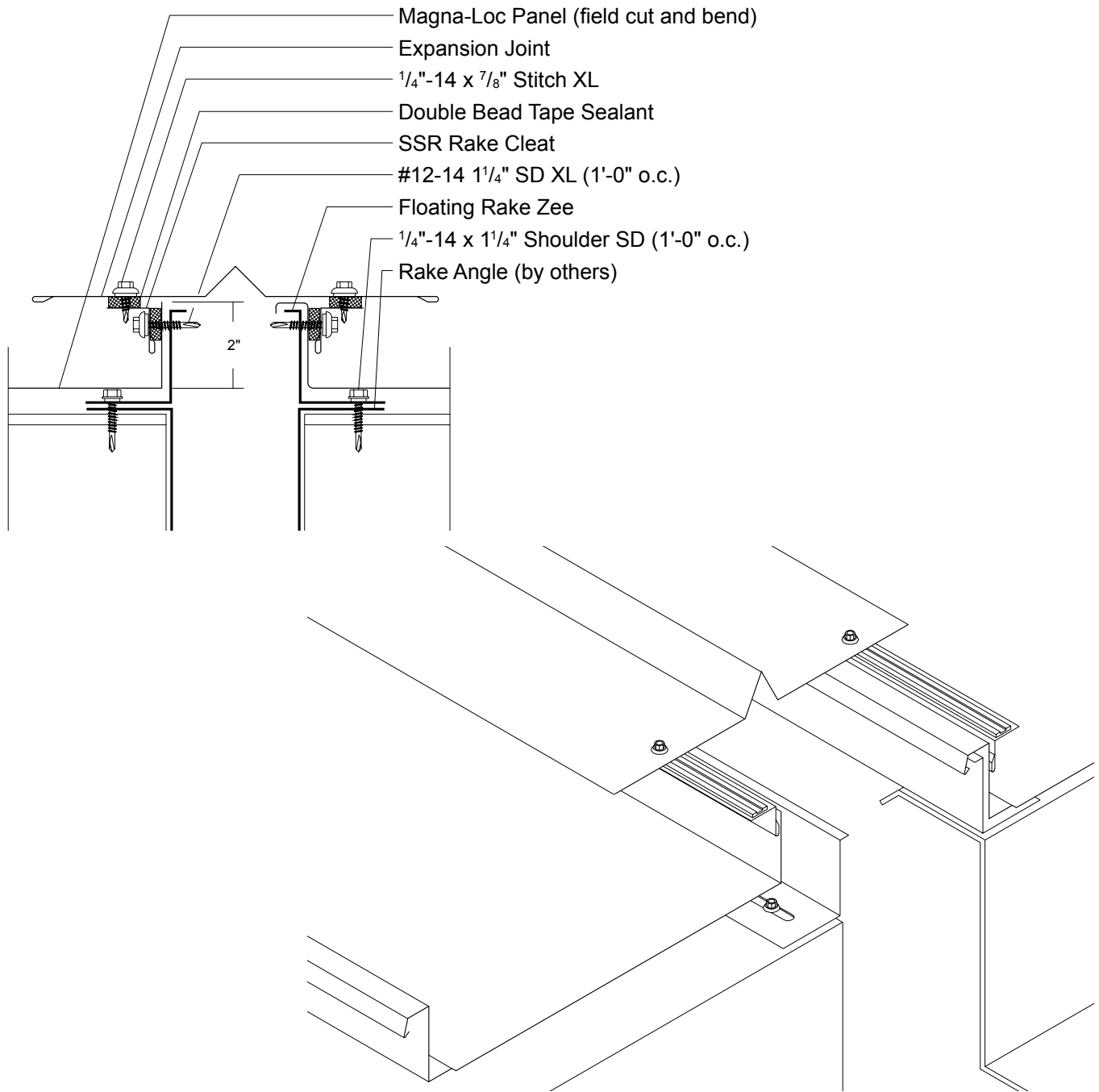

INSTALLATION NOTES

Magna-Loc Floating Rake Zees and Magna-Loc Panels must be installed prior to Expansion Joint installation (See pages 43-53).

1. With Magna-Loc panels nested against Magna-Loc Floating Rake Zees, apply a row of Double Bead Tape Sealant across upper side of panel ribs on both sides of Expansion Joint. (See page 51 for proper bending of panel if off module.)
2. Install SSR Rake Cleats over Double Bead Tape Sealant on both sides. Fasten through SSR Rake Cleat, Tape Sealant, panel, and into Floating Rake Zee with #12-14 x 1 1/4" Self Driller XL screws, 1'-0" o.c. on both sides of Expansion Joint.
3. Apply a row of Double Bead Tape Sealant across top leg of SSR Rake Cleats.
4. Install Expansion Joint flashing on top legs of SSR Rake Cleats. Fasten through Expansion Joint flashing, Tape Sealant, and into SSR Rake Cleat with 1/4"-14 x 7/8" Stitch XL, 1'-0" o.c. on both sides of Expansion Joint.
5. If two or more flashings are required, lap the flashing over the previously installed flashing by a minimum of 2" placing a bead of Tube Sealant between the flashings and securing with Pop Rivets, 2.5" o.c.

**1/2:12 Slope
Minimum**

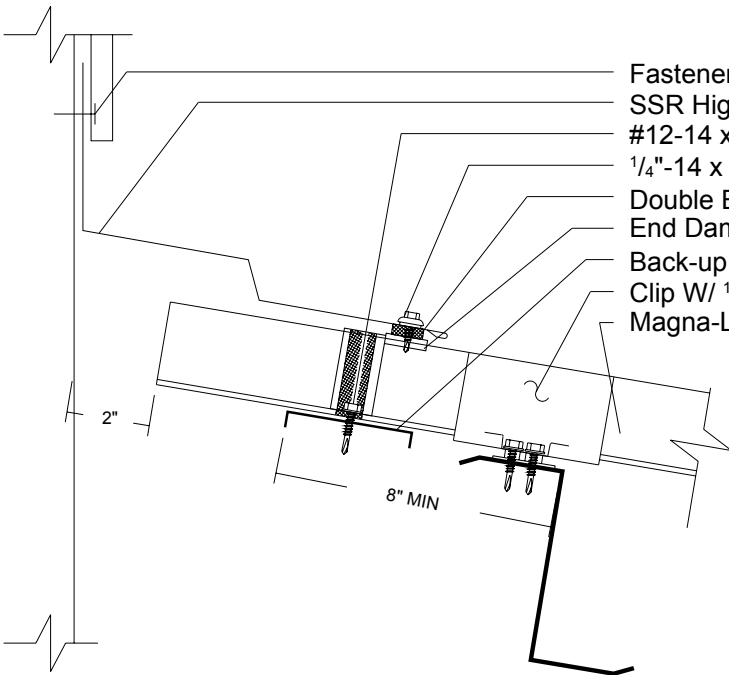

- Fastener (by others)
- SSR High Side Pitch Break
- #12-14 x 1" SD N/W (see below)
- 1/4"-14 x 7/8" Stitch XL (3 per panel)
- Double Bead Tape Sealant
- End Dam
- Back-up Channel
- Clip W/ 1/4"-14 x 1 1/2" SD N/W
- Magna-Loc Panel

2"

8" MIN

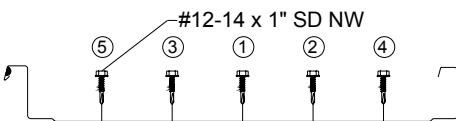
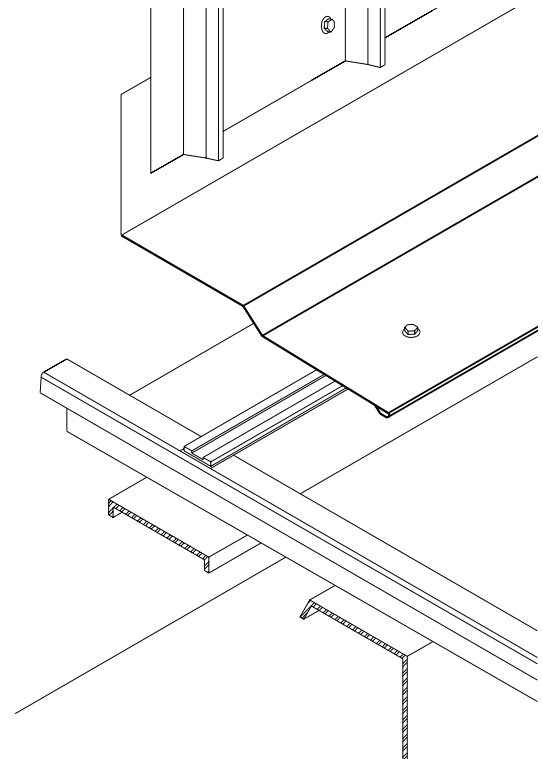

FASTENING PATTERN

INSTALLATION NOTES

1. Once panels have been installed, slide Back-Up Channel under upper edge of panels. Position Back-Up Channel to allow for proper installation of endwall assembly. Use C-clamps to hold Back-Up Channel in place.
2. Apply a row of Double Bead Tape Sealant across panel, up and over all ribs approximately 6"-8" from panel end.
3. Install Magna-Loc End Dams over Tape Sealant. Before continuing make sure End Dam placement will accommodate SSR High Side Pitch Break.
4. Once closure is set in Tape Sealant, fasten through End Dam, Tape Sealant, Magna-Loc panel, and into Back-Up Channel with (5) #12-14 x 1" SD N/W per panel. C-clamps may be removed once closures have been fastened.
5. Once all End Dams have been installed, place a row of Double Bead Tape Sealant across top of End Dams. Tube Sealant must be used to fill any and all gaps left around End Dams.
6. Install SSR High Side Pitch Break and secure to top leg of End Dams with 1/4"-14 x 7/8" Stitch XL at the spacing shown above and to parapet wall with appropriate fastener, 12"o.c.
7. Install Counter Flashing, Reglet, or wall panel and fasten to parapet wall with appropriate fastener, 12"o.c. If Counter Flashing or Reglet is used, seal to parapet wall with Tube Sealant.
8. If two or more flashings are required, lap the flashing over the previously installed flashing by a minimum of 2" placing a bead of Tube Sealant between the flashings and securing with Pop Rivets, 2.5"o.c.

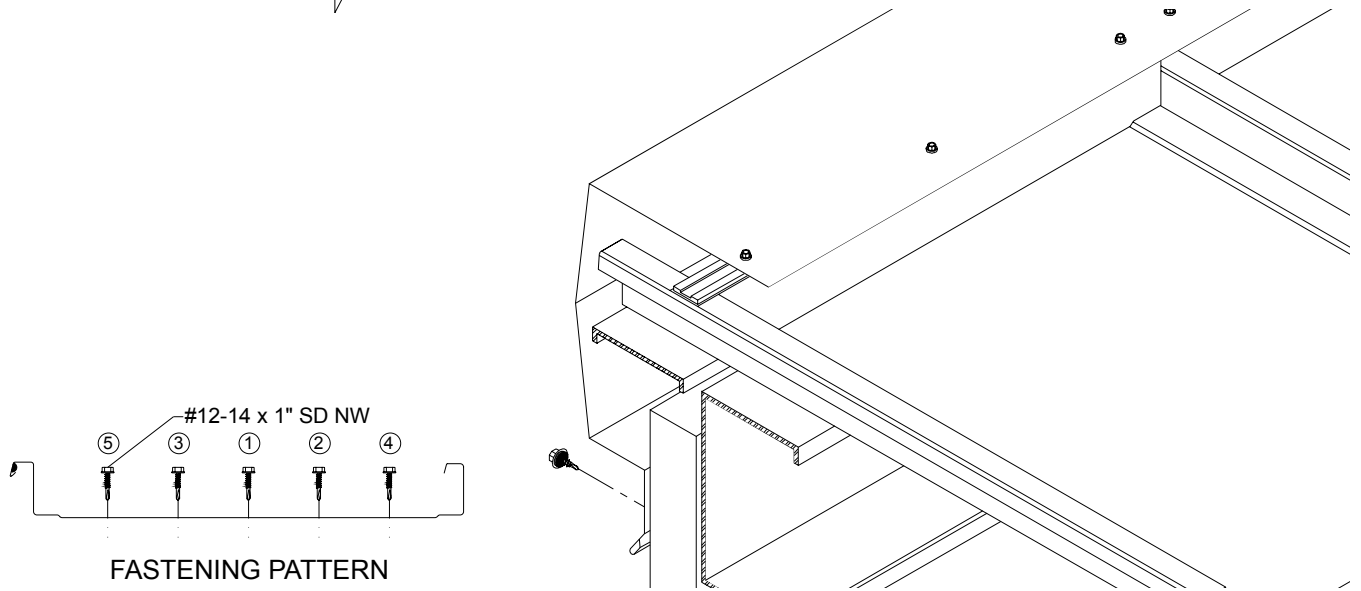
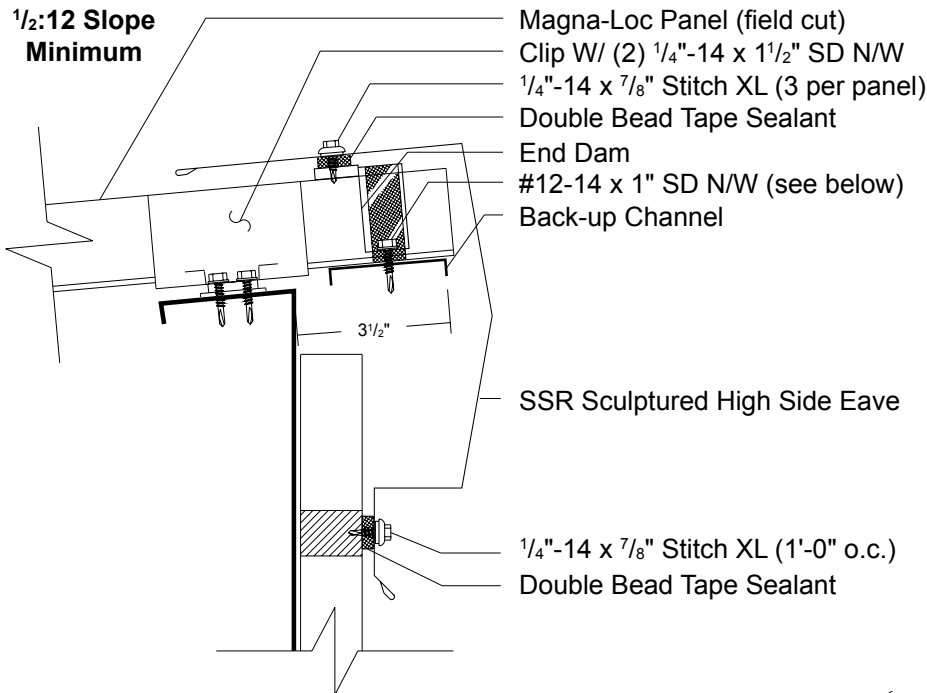

INSTALLATION NOTES

1. Once panels have been installed, slide Back-Up Channel under upper edge of panels. Position Back-Up Channel to allow for proper installation of High Side Eave assembly. Use C-clamps to hold Back-Up Channel in place.
2. Apply a row of Double Bead Tape Sealant across panel, up and over all ribs approximately 2"-4" from panel end.
3. Install Magna-Loc End Dams over tape sealant. Before continuing make sure End Dam placement will accommodate SSR Sculptured High Side Eave flashing.
4. Once Closure is set in Tape Sealant, fasten through End Dam, Tape Sealant, Magna-Loc panel, and into Back-Up Channel with (5) #12-14 x 1" SD N/W per panel. C-clamps may be removed once closures have been fastened.
5. Once all End Dams have been installed, place a row of Double Bead Tape Sealant across top of End Dams. Tube Sealant must be used to fill any and all gaps left around End Dams.
6. Install SSR Sculptured High Side Eave flashing and secure to top leg of End Dams with 1/4"-14 x 7/8" Stitch XL at the spacing shown above.
7. Fasten SSR Sculptured High Side Eave flashing to finished wall with appropriate fastener, 1'-0" o.c.
8. If two or more flashings are required, lap the flashing over the previously installed flashing by a minimum of 2" placing a bead of Tube Sealant between the flashings and securing with Pop Rivets, 2.5" o.c.

**1/2:12 Slope
Minimum**

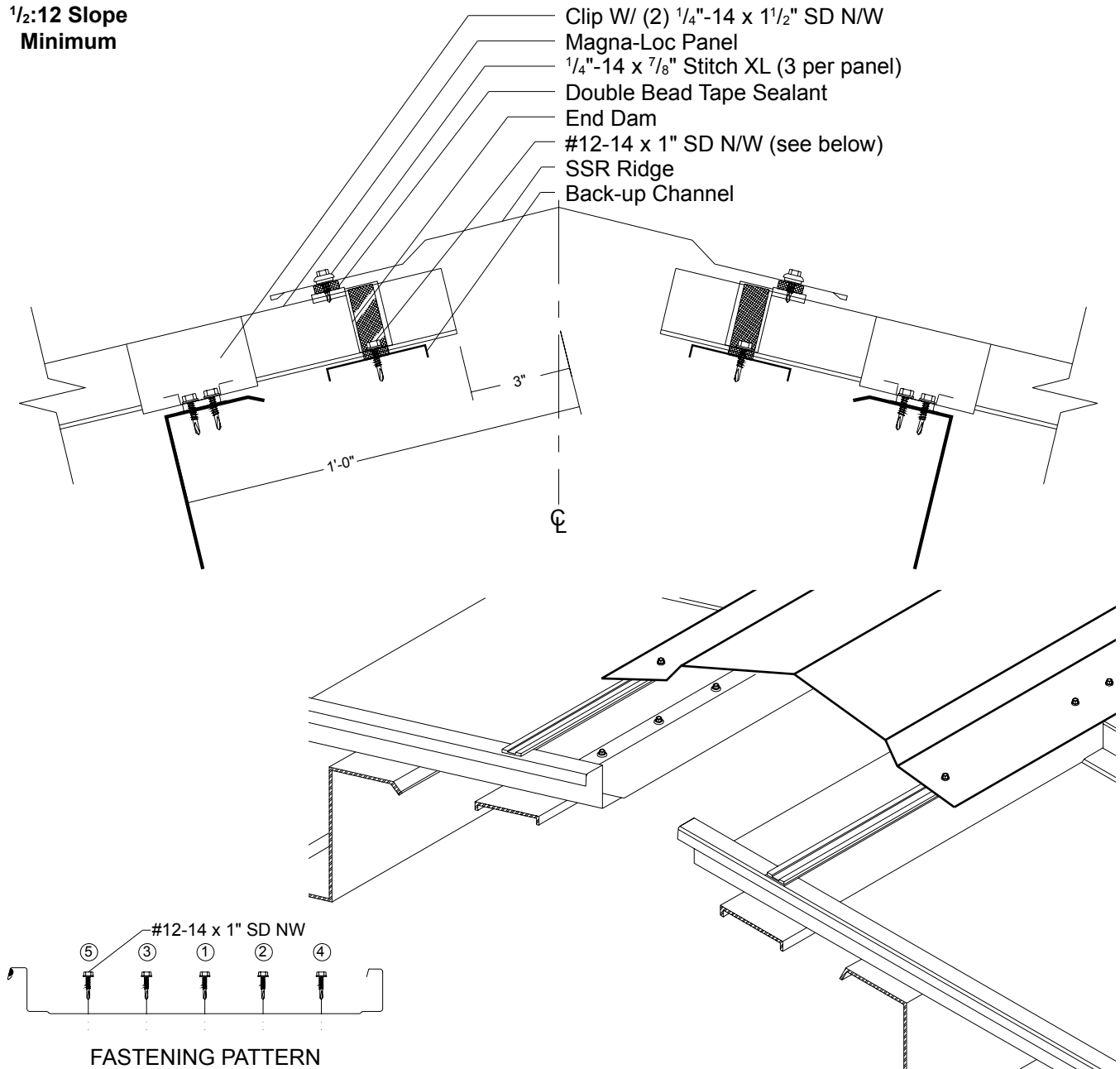

INSTALLATION NOTES

1. Once panels have been installed, slide Back-Up Channel under upper edge of panels. Position Back-Up Channel to allow for proper installation of ridge assembly. Use C-clamps to hold Back-Up Channel in place.
2. Apply a row of Double Bead Tape Sealant across panel, up and over all ribs approximately 2"-4" from panel end on both sides of ridge.
3. Install Magna-Loc End Dams over Tape Sealant. Before continuing make sure End Dam placement will accommodate SSR Ridge.
4. Once Closure is set in Tape Sealant, fasten through End Dam, Tape Sealant, Magna-Loc panel, and into Back-Up Channel with (5) #12-14 x 1" SD N/W per panel. C-clamps may be removed once Closures have been fastened.
5. Once all End Dams have been installed, place a row of Double Bead Tape Sealant across top of End Dams on both sides of ridge. Tube Sealant must be used to fill any and all gaps left around End Dams.
6. Install SSR Ridge flashing and secure to top leg of End Dams with 1/4"-14 x 7/8" Stitch XL at the spacing shown above.
7. If two or more flashings are required, lap the flashing over the previously installed flashing by a minimum of 2" placing a bead of Tube Sealant between the flashings and securing with Pop Rivets, 2.5" o.c.

**1/2:12 Slope
Minimum**

- Magna-Loc Panel (field cut)
- Clip W/ (2) 1/4"-14 x 1 1/2" SD N/W
- 1/4"-14 x 7/8" Stitch XL (3 per panel)
- Double Bead Tape Sealant
- Z-Closure (field cut)
- #12-14 x 1" SD N/W (see below)
- Back-up Channel
- 20" Hip Cover

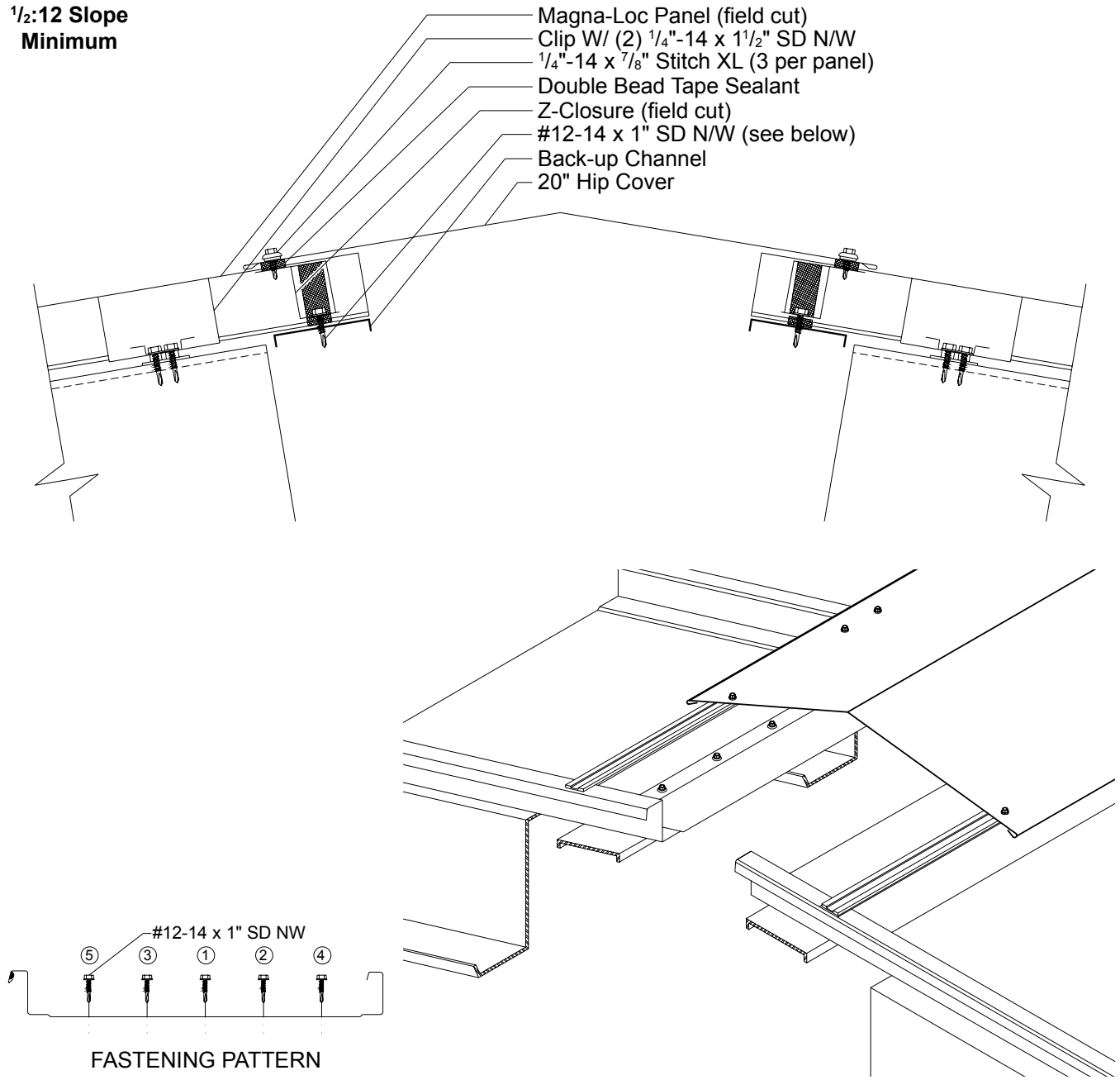

INSTALLATION NOTES

1. Once panels have been installed, slide Back-Up Channel under upper edge of panels. Position Back-Up Channel to allow for proper installation of hip assembly. Use C-clamps to hold Back-Up Channel in place.
2. Apply a row of Double Bead Tape Sealant across panel, up and over all ribs approximately 2"-4" from panel end on both sides of hip.
3. Install field cut Z-Closure over tape sealant. (See page 79 for preparing Z-Closures.) Before continuing make sure Z-Closure placement will accommodate 20" Hip flashing.
4. Once Closure is set in Tape Sealant, fasten through Z-Closure, Tape Sealant, Magna-Loc panel, and into Back-Up Channel with (5) #12-14 x 1" SD N/W per panel. C-clamps may be removed once Closures have been fastened.
5. Once all Z-Closures have been installed, place a row of Double Bead Tape Sealant across top of Closures on both sides of hip. Tube Sealant must be used to fill any and all gaps left around Z-Closures.
6. Install 20" Hip flashing and secure to top leg of Z-Closure with 1/4"-14 x 7/8" Stitch XL at the spacing shown above.
7. If two or more flashings are required, lap the flashing over the previously installed flashing by a minimum of 2" placing a bead of Tube Sealant between the flashings and securing with Pop Rivets, 2.5"o.c.

**1/2:12 Slope
Minimum**

- Magna-Loc Panel
- Clip W/ (2) 1/4"-14 x 1 1/2" SD N/W
- 1/8" x 3/16" Pop Rivet (1'-0" o.c.)
- Double Bead Tape Sealant
- #14-13 x 2" Dekfast (1'-0" o.c.)
- Vent Material
- #12-14 x 1" SD N/W (see below)
- Vent Drip
- Offset Cleat
- Vented Ridge Cover
- End Dam
- Back-up Channel

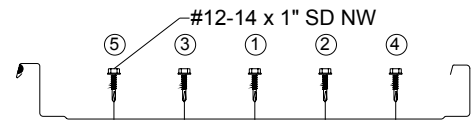
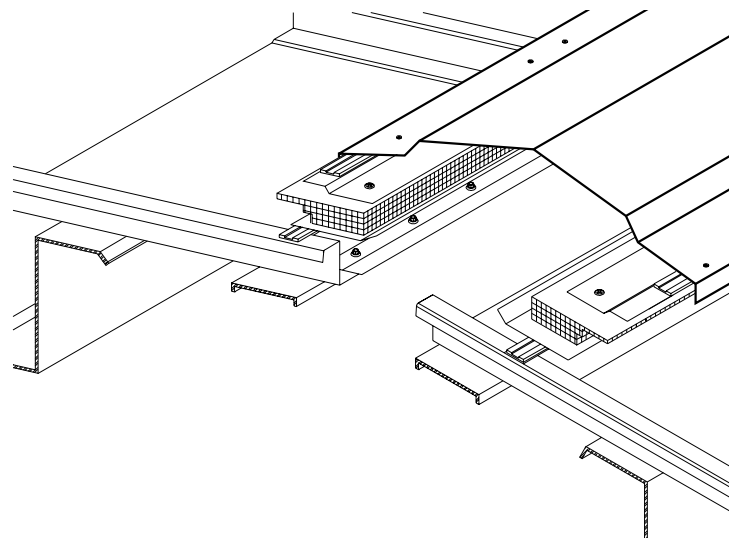
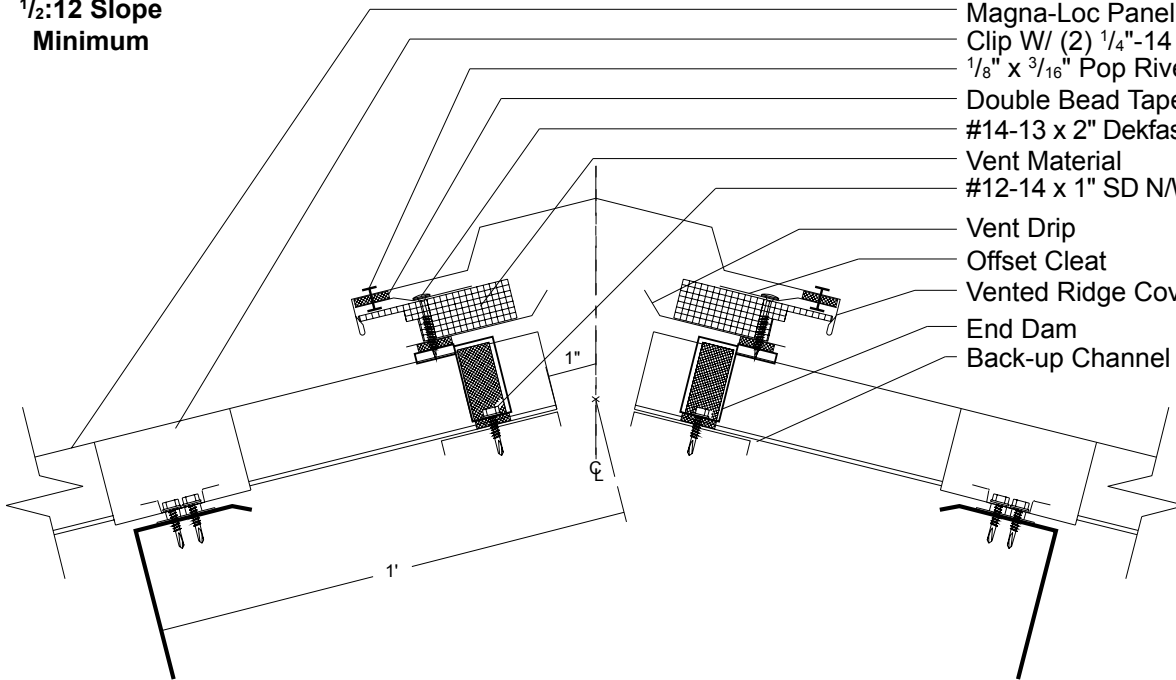

FASTENING PATTERN

INSTALLATION NOTES

1. Once panels have been installed, slide Back-Up Channel under the upper edge of panels. Position Back-Up Channel to allow for proper installation of vented ridge assembly. Use C-clamps to hold Back-Up Channel in place.
2. Apply a row of Double Bead Tape Sealant across panel, up and over all ribs approximately 0"-2" from panel end on both sides of ridge.
3. Install Magna-Loc End Dams over Tape Sealant. Before continuing make sure End Dam placement will accommodate Vented Ridge Cover.
4. Once closure is set in Tape Sealant, fasten through End Dam, Tape Sealant, Magna-Loc panel, and into Back-Up Channel with (5) #12-14 x 1" SD N/W per panel. C-clamps may be removed once Closures have been fastened.
5. Once all End Dams have been installed, place a row of Double Bead Tape Sealant across top of End Dams on both sides of ridge. Tube Sealant must be used to fill any and all gaps left around End Dams.
6. Install Vent Drip, Vent Material, and Offset Cleat (in order) and fasten to top leg of End Dam with #14 Dekfasts at 1'-0" o.c.
7. Apply a row of Double Bead Tape Sealant across outer leg of Offset Cleat.
8. Install Vented Ridge Cover and secure to outer leg of Offset Cleat with Pop Rivets at 1'-0" o.c.
9. If two or more flashings are required, lap the flashing over the previously installed flashing by a minimum of 2" placing a bead of Tube Sealant between the flashings and securing with Pop Rivets 2.5" o.c.

**1/2:12 Slope
Minimum**

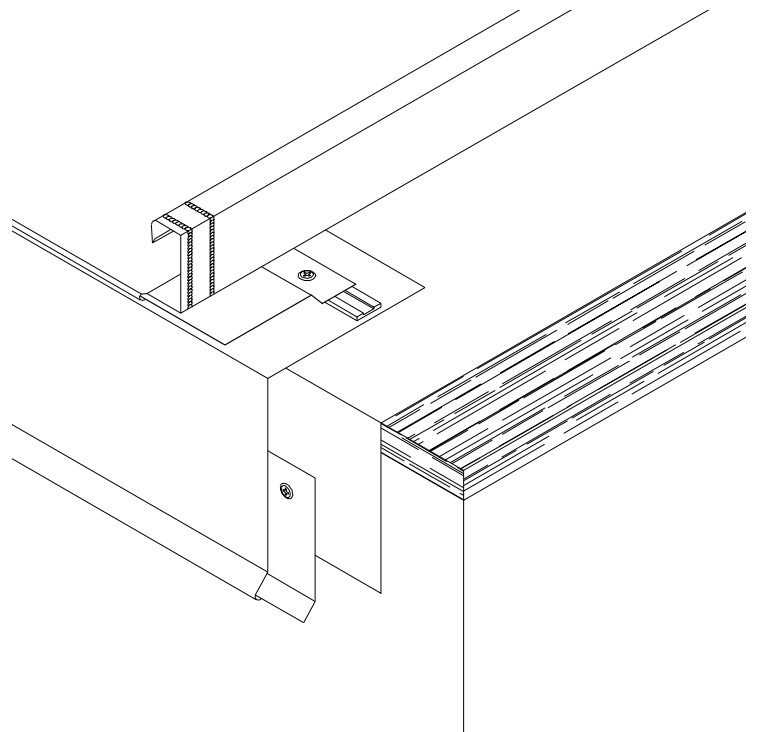
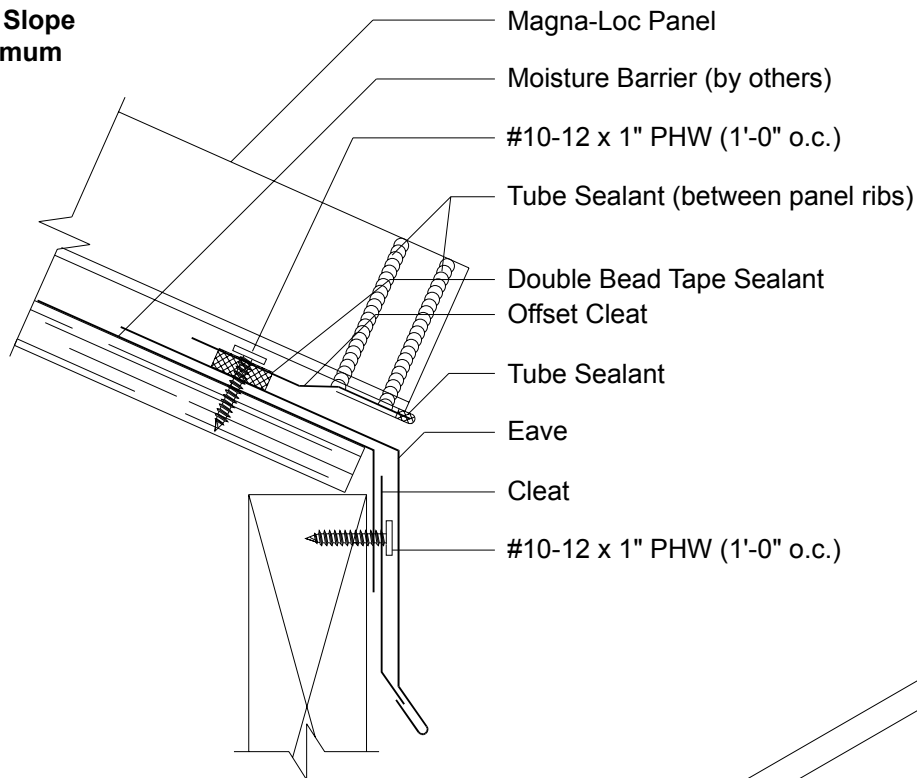

INSTALLATION NOTES

All Eave flashings must be installed prior to panel installation.

1. Position and install Cleat to wall with appropriate fastener, 12"o.c. Make sure Cleat allows for proper Eave attachment.
2. Install Eave flashing by sliding open hem onto Cleat and resting the Eave flashing back against substrate. To hold Eave flashing in place fasten to substrate with #10-12 x 1" Pancake Head fastener, 4'-0"o.c.
3. Apply a row of Double Bead Tape Sealant across Eave flashing approximately 2"-3" from face of Eave flashing.
4. Properly align and install Offset Cleat so that Magna-Loc panel will be flush with Eave flashing. Fasten through Offset Cleat, Tape Sealant, Eave Flashing and into substrate with Pancake Head fastener at 1'-0"o.c.
5. Apply a continuous bead of Tube Sealant along outer edge of Offset Cleat in panel hem.
6. If two or more flashings are required, lap the flashing over the previously installed flashing by a minimum of 2" placing a bead of Tube Sealant between the flashings and securing with Pop Rivets, 2.5"o.c.
7. Install Magna-Loc panel by engaging field hemmed panel end (see page 82) over Offset Cleat. Two beads of Tube Sealant must be applied up and over male leg of each Magna-Loc panel during panel installation (see page 49).

**1/2:12 Slope
Minimum**

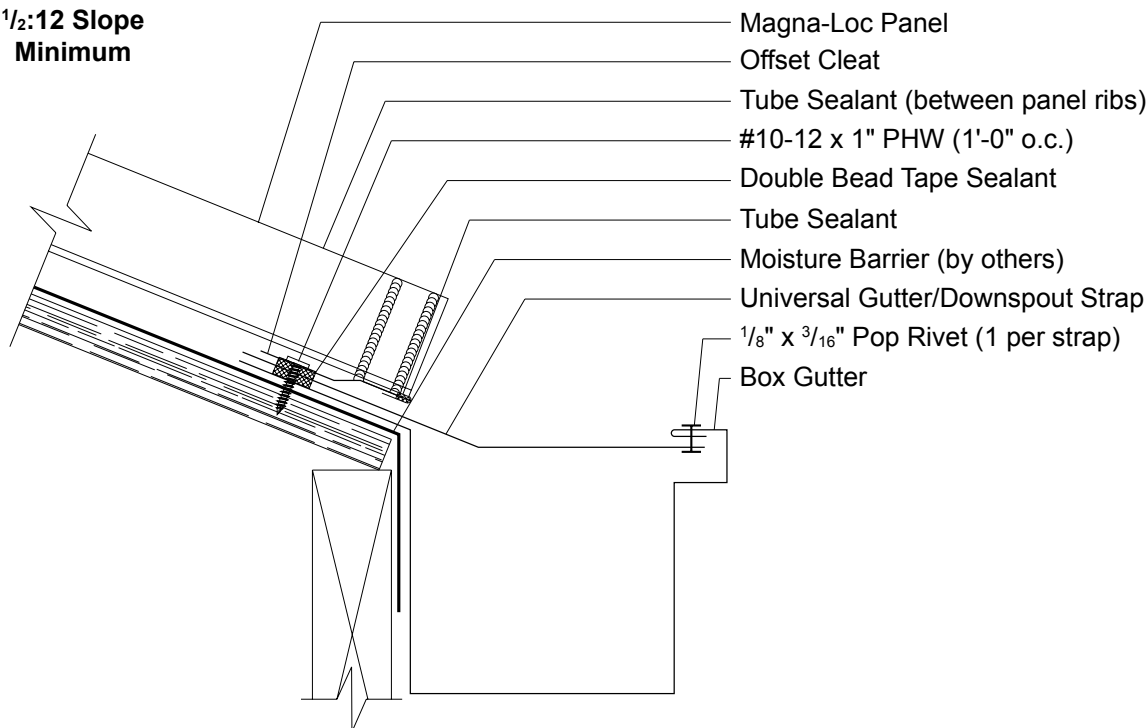

- Magna-Loc Panel
- Offset Cleat
- Tube Sealant (between panel ribs)
- #10-12 x 1" PHW (1'-0" o.c.)
- Double Bead Tape Sealant
- Tube Sealant
- Moisture Barrier (by others)
- Universal Gutter/Downspout Strap
- 1/8" x 3/16" Pop Rivet (1 per strap)
- Box Gutter

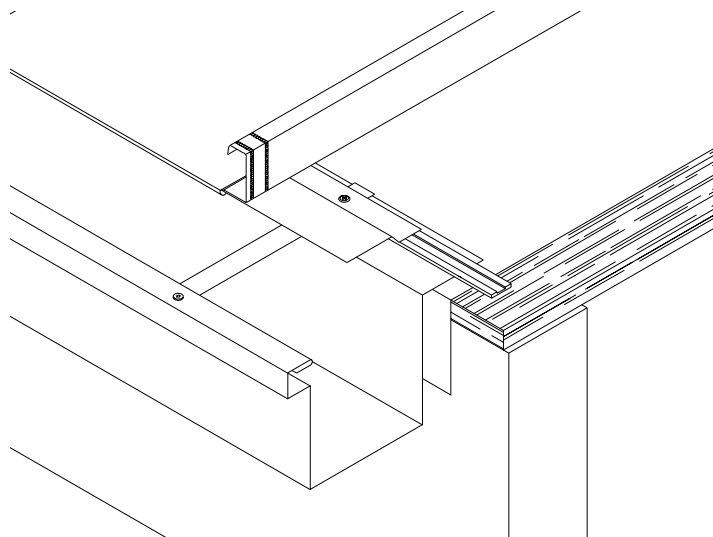

CAUTION

In locations where heavy rainfall or severe ice and snow may occur, Metal Sales' standard gutters may not be suitable for use.

INSTALLATION NOTES

All Gutter flashings must be installed prior to panel installation.

1. Install Box Gutter flashing back against substrate. To hold Box Gutter flashing in place fasten to substrate with #10-12x1" Pancake Head fastener, 4'-0" o.c.
2. Install Universal Gutter/Downspout Straps every 3'-0" of gutter length. Fasten to Box Gutter under front lip with Pop Rivets.
3. Apply a row of Double Bead Tape Sealant across Box Gutter flashing approximately 2"-3" from inside of Box Gutter flashing.
4. Properly align and install Offset Cleat so that Magna-Loc panel will be flush with inside of Box Gutter flashing. Fasten through Offset Cleat, Tape Sealant, Universal Gutter Strap, Box Gutter and into substrate with Pancake Head fastener 1'-0" o.c. Fastener must pass through Universal Gutter Downspout Strap.
5. If two or more flashings are required, lap the flashing over the previously installed flashing by a minimum of 2" placing a head of Tube Sealant between the flashings and securing with Pop Rivets, 2.5" o.c.
6. Install Magna-Loc panel by engaging field hemmed panel end (see page 82) over Offset Cleat. Two beads of Tube Sealant must be applied up and over male leg of each Magna-Loc panel during panel installation (see page 49).

**3:12 Slope
Minimum**

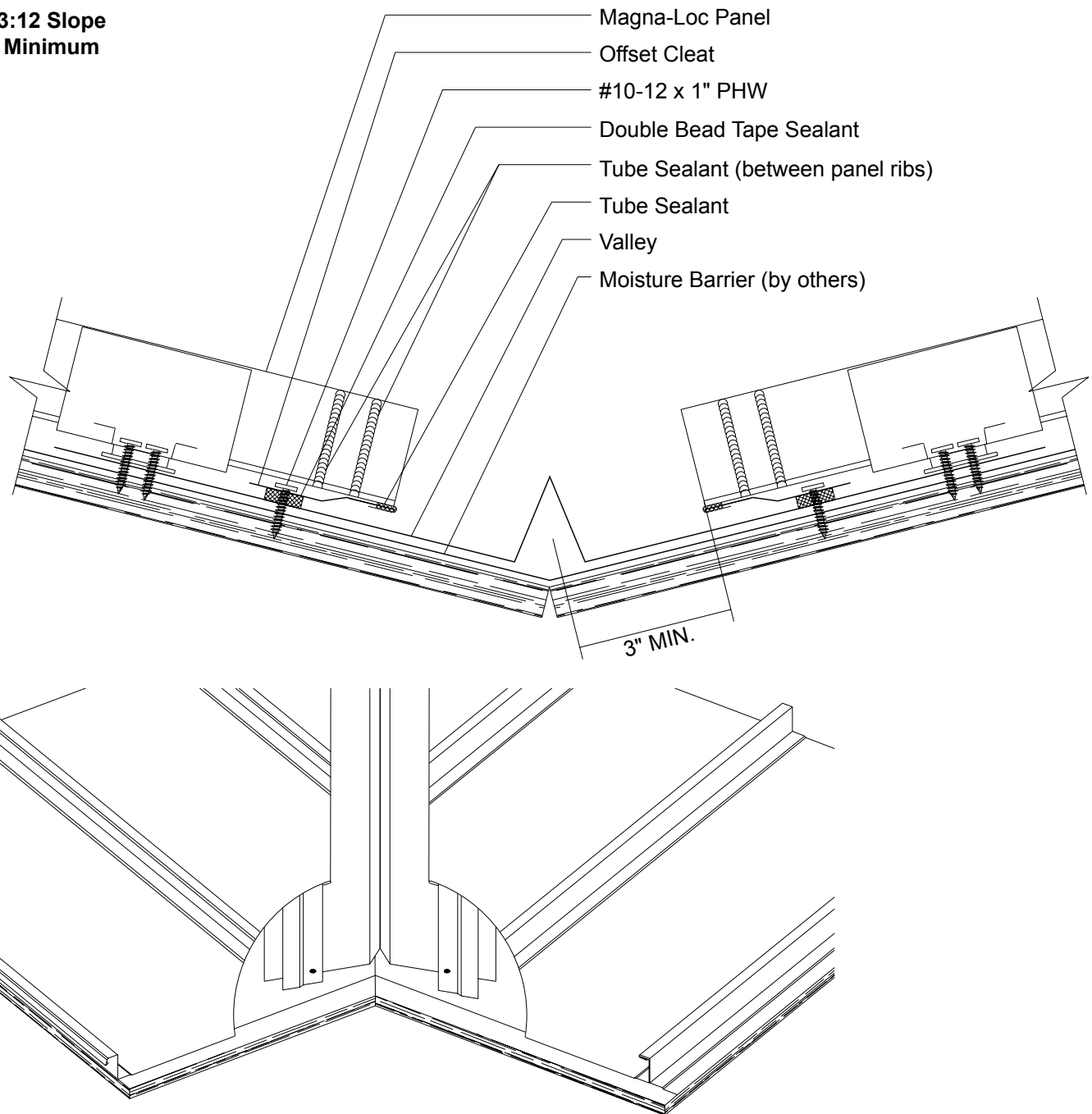

INSTALLATION NOTES

Valley flashing must be installed working from eave to peak if two or more flashings are required. It is recommended that an ice and water shield be placed along the valley beneath the flashing for added protection against moisture.

1. Install Valley flashing back against substrate. To hold Valley flashing in place fasten to substrate with #10-12 x 1" Pancake Head fastener, 4'-0" o.c.
2. If two or more flashings are required, lap the flashing over the previously installed flashing by a minimum of 2" placing a bead of Tube Sealant between the flashings and securing with Pop Rivets, 2.5" o.c.
3. Place a continuous row of Double Bead Tape Sealant across bottom leg of Offset Cleat and apply to both sides of valley.
4. Fasten through Offset Cleat, Tape Sealant, Valley flashing and into substrate with Pancake Head fastener, 1'-0" o.c.
5. Install Magna-Loc panel by engaging field hemmed panel end (see page 82) over Offset Cleat. Two beads of Tube Sealant must be applied up and over male leg of each Magna-Loc panel during panel installation (see page 49).

**1/2:12 Slope
Minimum**

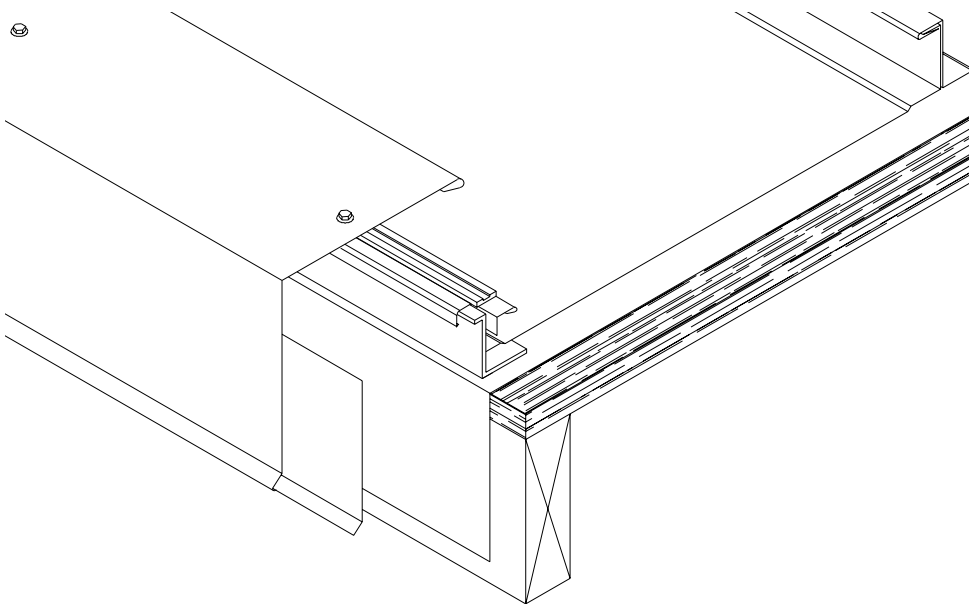
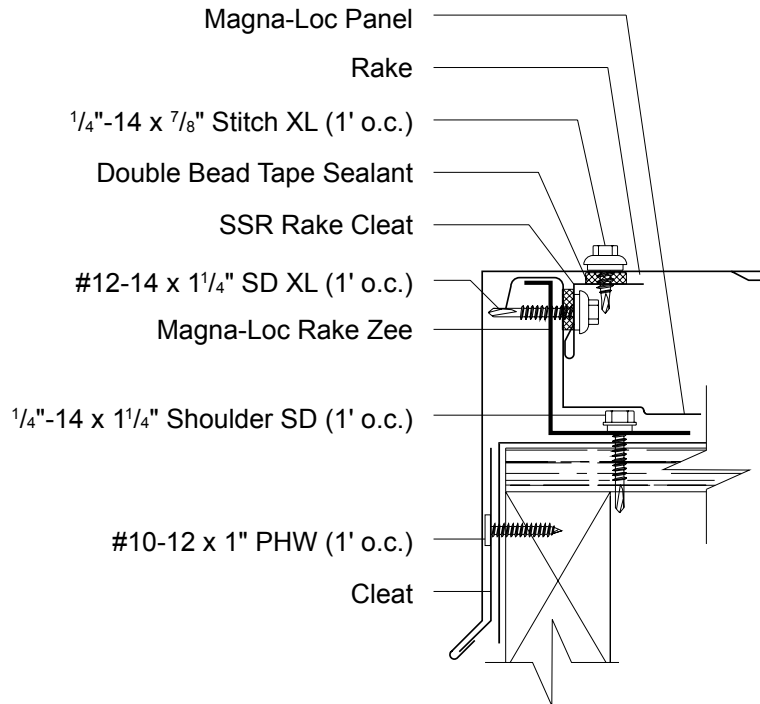

INSTALLATION NOTES

Magna-Loc Floating Rake Zee and Magna-Loc panels must be installed prior to rake installation (see pages 43-53).

1. Position and install Cleat to wall with appropriate fastener, 12"o.c. Make sure Cleat installation allows for proper Rake attachment.
2. With Magna-Loc panel properly nested and fastened against Floating Rake Zee, apply a row of Double Bead Tape Sealant across top of panel rib.
3. Install Rake flashing by sliding open hem onto Cleat and resting the Rake flashing on top of panel rib. Fasten through Rake, Sealant, and into Floating Rake Zee with 1/4"-14 x 7/8" Stitch XL, 12"o.c.
4. If two or more flashings are required, lap the flashing over the previously installed flashing by a minimum of 2" placing a bead of Tube Sealant between the flashings and securing with Pop Rivets 2.5"o.c.

**1/2:12 Slope
Minimum**

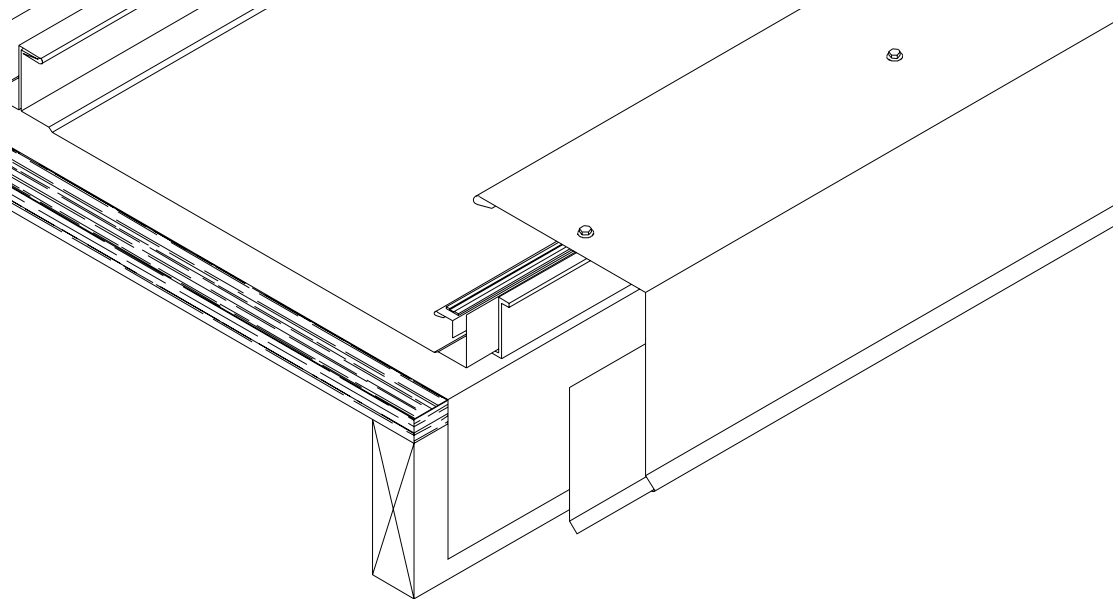
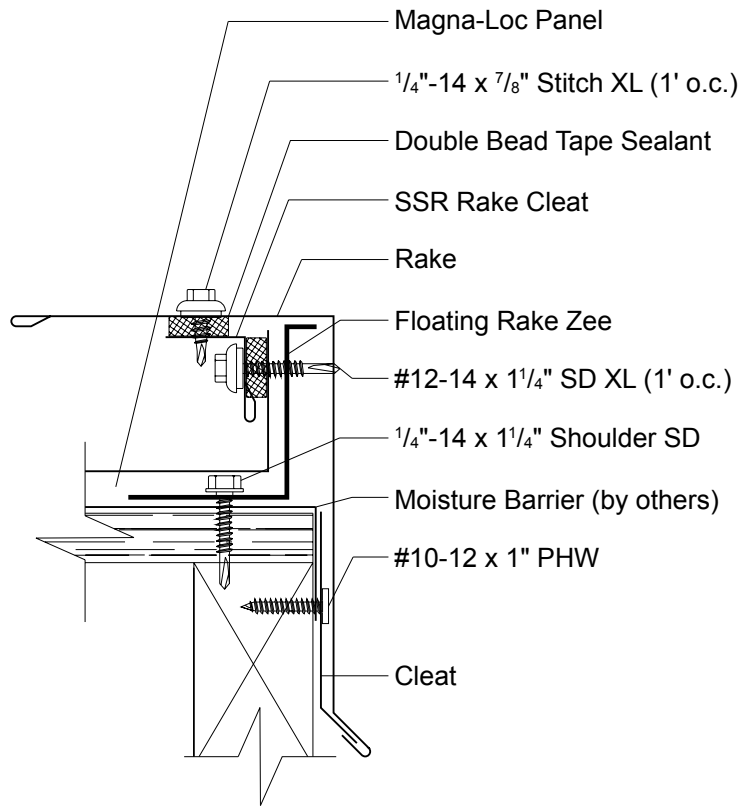

INSTALLATION NOTES

Magna-Loc Floating Rake Zee and Magna-Loc panels must be installed prior to rake installation (see pages 43-53).

1. Position and install Cleat to wall with appropriate fastener, 12"o.c. Make sure Cleat installation allows for proper Rake attachment.
2. With Magna-Loc panel properly nested and fastened against Floating Rake Zee, apply a row of Double Bead Tape Sealant across top of panel rib.
3. Install Rake flashing by sliding open hem onto Cleat and resting the Rake flashing on top of panel rib. Fasten through Rake, Sealant, and into Floating Rake Zee with 1/4"-14 x 7/8" Stitch XL, 12"o.c.
4. If two or more flashings are required, lap the flashing over the previously installed flashing by a minimum of 2" placing a bead of Tube Sealant between the flashings and securing with Pop Rivets 2.5"o.c.

**1/2:12 Slope
Minimum**

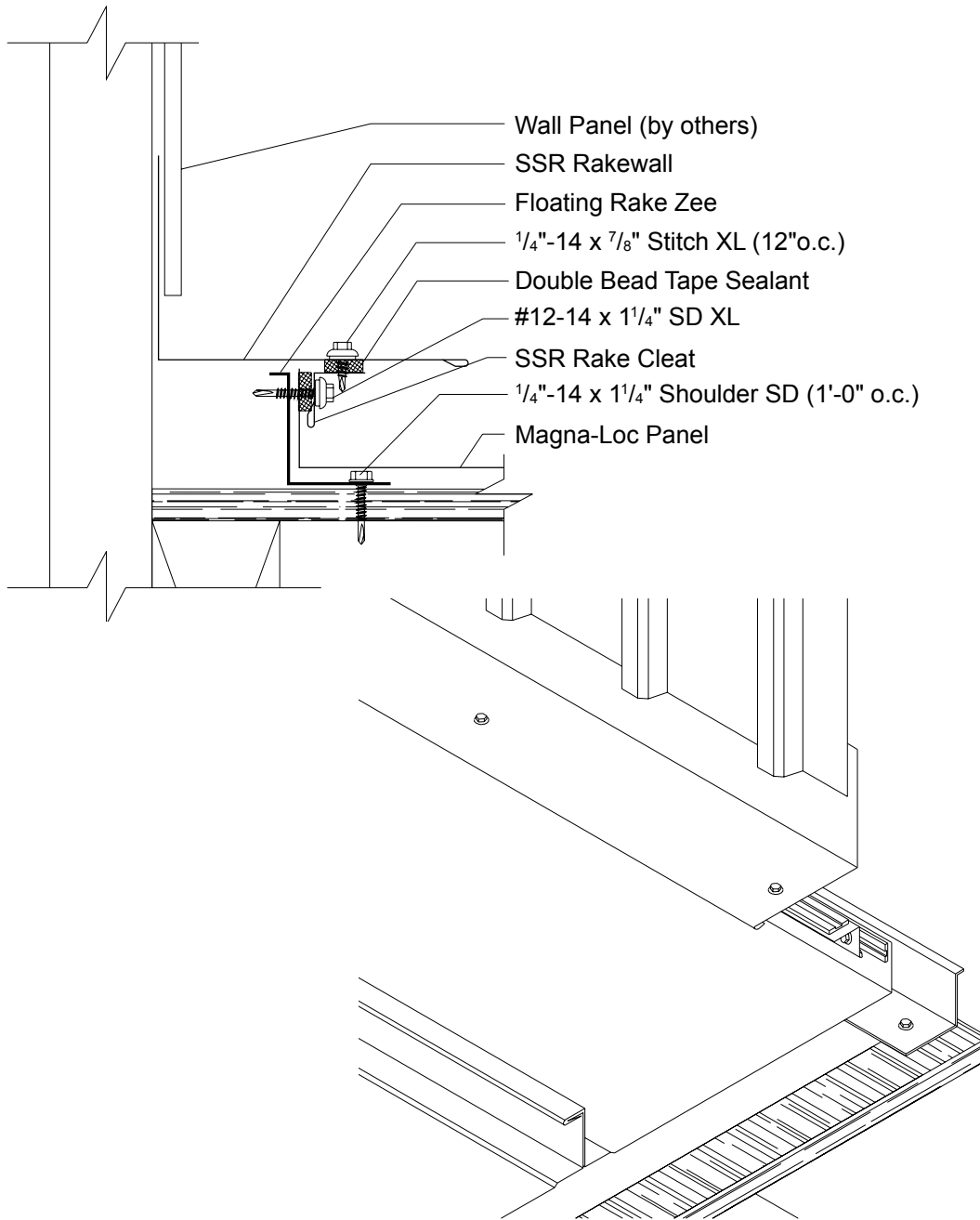

INSTALLATION NOTES

Magna-Loc Floating Rake Zee and Magna-Loc Panels must be installed prior to Rakewall installation (See pages 43-53).

1. With Magna-Loc panel nested against Magna-Loc Floating Rake Zee, apply a row of Double Bead Tape Sealant across upper side of field bent panel rib. (See page 51 for proper bending of panel.)
2. Install SSR Rake Cleat over Double Bead Tape Sealant. Fasten through SSR Rake Cleat, Tape Sealant, panel, and into Floating Rake Zee with #12-14 x 1 1/4" Self Driller XL screws, 1'-0" o.c.
3. Apply a row of Double Bead Tape Sealant across top leg of SSR Rake Cleat.
4. Install SSR Rakewall so that top of flashing is flush with top of SSR Rake Cleat and panel rib. Fasten through SSR Rakewall, Tape Sealant, and into SSR Rake Cleat with 1/4"-14 x 7/8" Stitch XL, 1'-0" o.c.
5. Install Counter Flashing, Reglet, or wall panel and fasten to parapet wall with appropriate fastener, 12" o.c. If Counter Flashing or Reglet is used, seal to parapet wall with tube sealant. Do NOT fasten SSR Rakewall to parapet wall.
6. If two or more flashings are required, lap the flashing over the previously installed flashing by a minimum of 2" placing a bead of Tube Sealant between the flashings and securing with Pop Rivets, 2.5" o.c.

**1/2:12 Slope
Minimum**

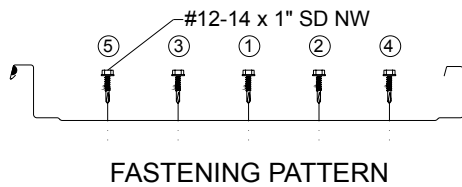
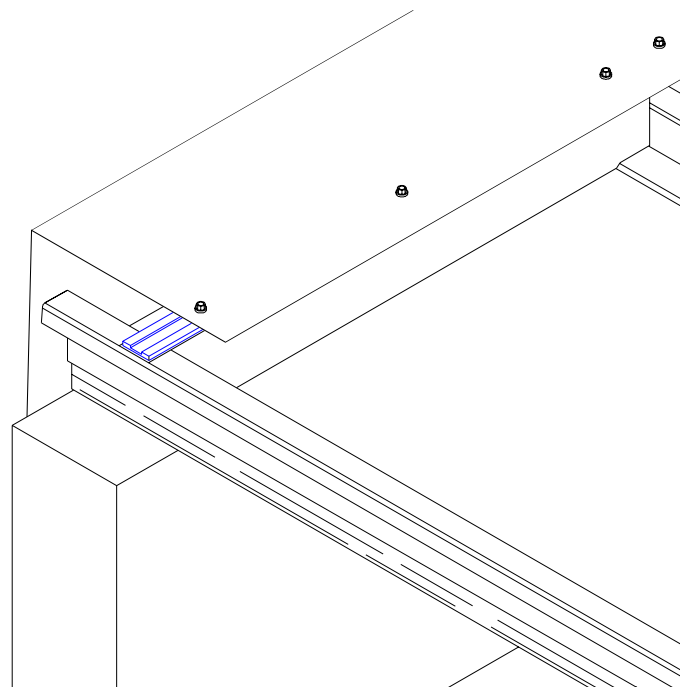
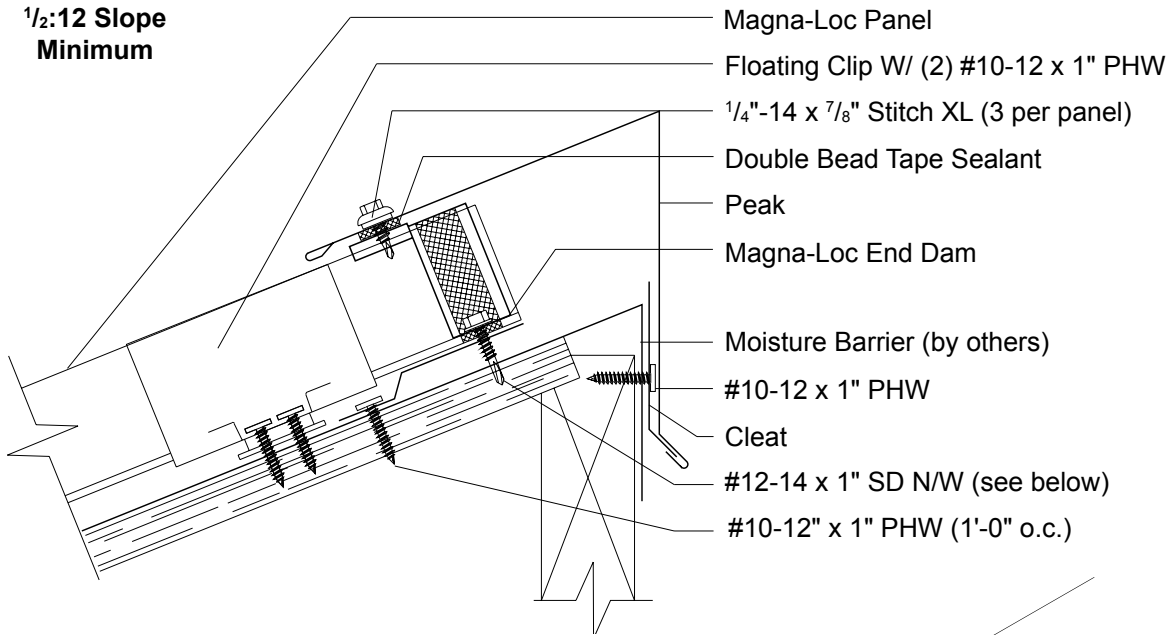

INSTALLATION NOTES

Magna-Loc Eave Plate and Magna-Loc panels must be installed prior to peak installation (see page 44).

- Once panels have been installed and properly sealed, (see page 45) apply a row of Double Bead Tape Sealant across panel, up and over all ribs approximately 2"-4" from panel end.
- Install Magna-Loc End Dams over Tape Sealant. Before continuing make sure End Dam placement will accommodate Peak Flashing.
- Once closure is set in Tape Sealant, fasten through End Dam, Double Bead Tape Sealant, Magna-Loc panel, and into Eave Plate with (5) #12-14x1" SD N/W per panel.
- Once all End Dams have been installed, place a row of Double Bead Tape Sealant across top of End Dams. Tube sealant must be used to fill any and all gaps left around End Dams.
- Position and install Cleat to wall with appropriate fastener, 12"o.c. Make sure Cleat allows for proper Peak attachment.
- Install Peak flashing by sliding open hem onto Cleat and resting the Peak flashing back over End Dams. Secure to top leg of End Dams with 1/4"-14 x 7/8" Stitch XL at the spacing shown above.
- If two or more flashings are required, lap the flashing over the previously installed flashing by a minimum of 2" placing a bead of Tube Sealant between the flashings and securing with Pop Rivets, 2.5"o.c.

**1/2:12 Slope
Minimum**

- Floating Clip
- Magna-Loc Panel
- 1/4"-14 x 7/8" Stitch XL (3 per panel)
- Magna-Loc End Dam or Z-Closure
- #10-12 x 1" PHW (1' o.c.)
- #12-14 x 1" SD N/W (see below)
- Double Bead Tape Sealant
- Eave Plate
- Moisture Barrier (by others)
- 20" Ridge Cover

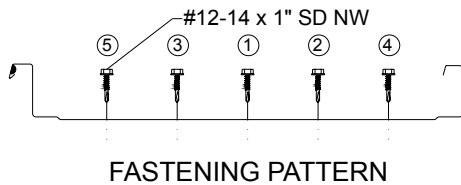
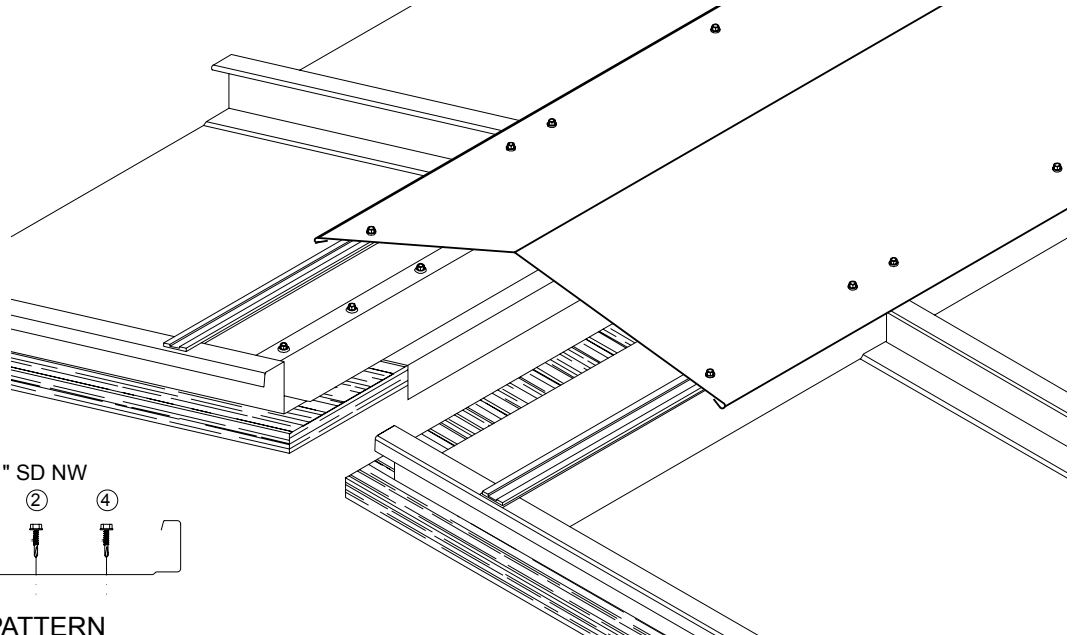
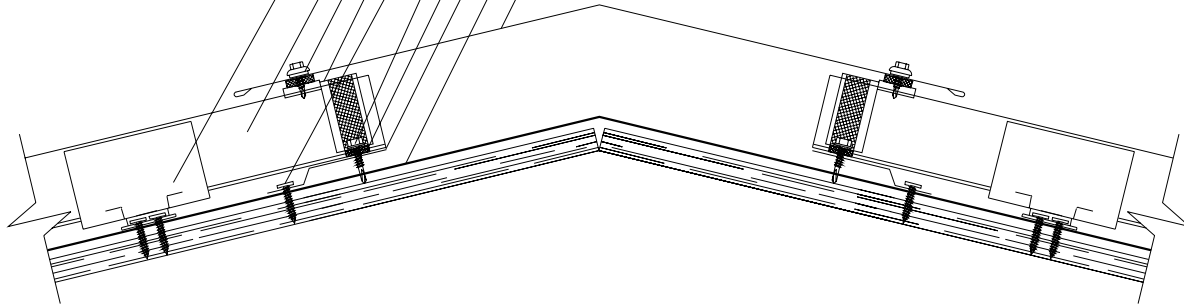

INSTALLATION NOTES

Magna-Loc Eave Plate and Magna-Loc panels must be installed prior to Ridge/Hip installation (see pages 43-53).

1. Once panels have been installed and properly sealed, (see page 45) apply a row of Double Bead Tape Sealant across panel, up and over all ribs approximately 2"-4" from panel end on both sides of ridge/hip.
2. For a ridge, install Magna-Loc End Dams over Tape Sealant. For a hip, install a field cut Z-Closure over Tape Sealant (see page 79 for preparing Z-Closures). Before continuing make sure End Dam placement will accommodate 20" Ridge/Hip Cover.
3. Once Closure is set in Tape Sealant, fasten through End Dam, Tape Sealant, Magna-Loc panel, and into Eave Plate with (5) #12-14 x 1" SD N/W per panel.
4. Once all End Dams have been installed, place a row of Double Bead Tape Sealant across top of End Dams on both sides of ridge/hip. Tube Sealant must be used to fill any and all gaps left around End Dams.
5. Install 20" Ridge/Hip flashing and secure to top leg of End Dams with 1/4"-14 x 7/8" Stitch XL at the spacing shown above.
6. If two or more flashings are required, lap the flashing over the previously installed flashing by a minimum of 2" placing a bead of Tube Sealant between the flashings and securing with Pop Rivets 2.5"o.c.

MAGNA-LOC VENTED RIDGE WITH Z-CLOSURE

**1/2:12 Slope
Minimum**

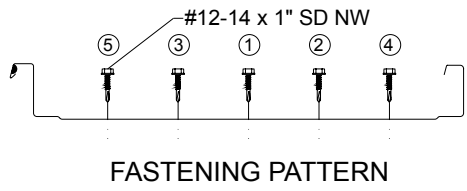
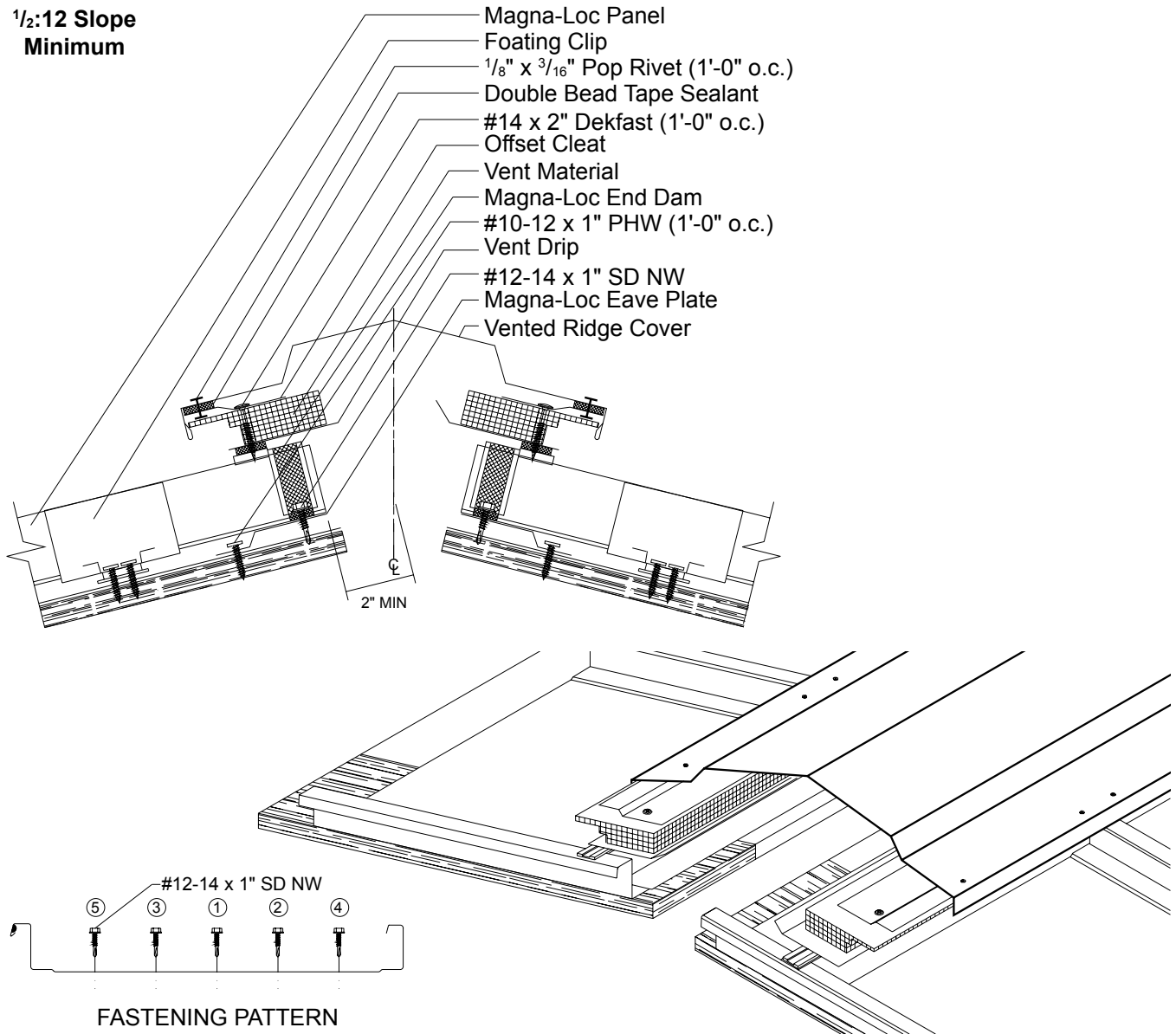

INSTALLATION NOTES

- Magna-Loc Eave Plate and Magna-Loc panels must be installed prior to Vented Ridge installation (see pages 43-53).**
1. Once panels have been installed, slide Back-Up Channel under upper edge of panels. Position Back-Up Channel to allow for proper installation of vented ridge assembly. Use C-clamps to hold Back-Up Channel in place.
 2. Apply a row of Double Bead Tape Sealant across panel, up and over all ribs approximately 0"-2" from panel end on both sides of ridge.
 3. Install Magna-Loc End Dams over Tape Sealant. Before continuing make sure End Dam placement will accommodate Vented Ridge Cover.
 4. Once closure is set in Tape Sealant, fasten through End Dam, Tape Sealant, Magna-Loc panel, and into Back-Up Channel with (5) #12-14 x 1" SD N/W per panel. C-clamps may be removed once Closures have been fastened.
 5. Once all End Dams have been installed, place a row of Double Bead Tape Sealant across top of End Dams on both sides of ridge. Tube Sealant must be used to fill any and all gaps left around End Dams.
 6. Install Vent Drip, Vent Material, and Offset Cleat (in order) and fasten to top leg of End Dam with #14 Dekfasts at 1'-0" o.c.
 7. Apply a row of Double Bead Tape Sealant across outer leg of Offset Cleat.
 8. Install Vented Ridge Cover and secure to outer leg of Offset Cleat with Pop Rivets at 1'-0" o.c.
 9. If two or more flashings are required, lap the flashing over the previously installed flashing by a minimum of 2" placing a bead of Tube Sealant between the flashings and securing with Pop Rivets, 2.5" o.c.

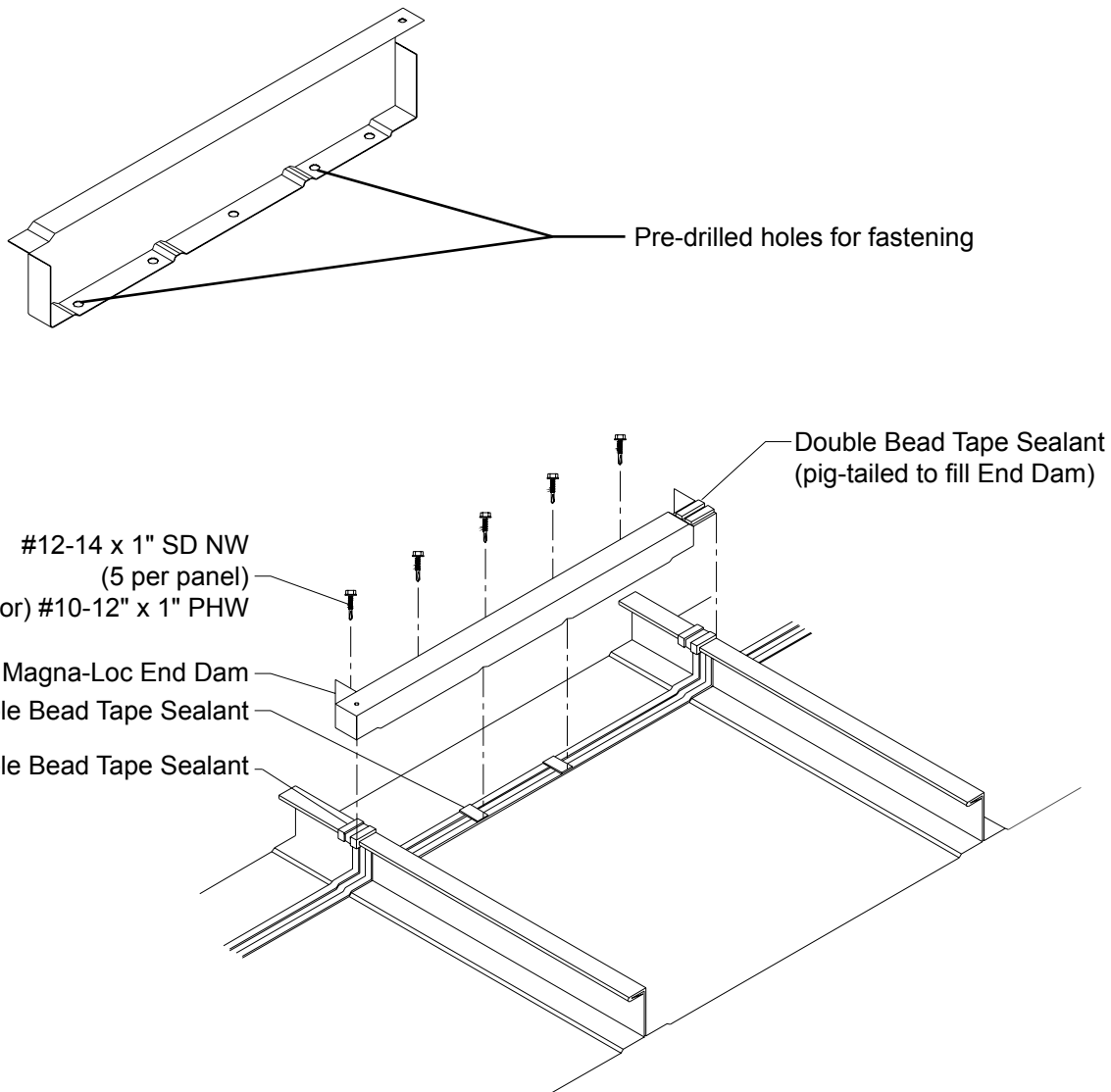

*(Pig-tailed to fill pencil ribs in End Dam)

INSTALLATION NOTES

Note: The End Dam is used to close off the high end of the panel on applications over open framing. Before installation of End Dam can begin, all roof panels must be seamed. (See seaming panels on pages 52 and 53 for proper seaming instructions.)

Steps:

1. Apply Double Bead Tape Sealant down the female leg. across the panel and up the male leg 2" from the end of the panel.
2. Place the End Dam on Double Bead Tape Sealant making sure the punched lower leg is towards the ridge. The punched lower leg should be 2" from the end of the panel.
3. Slide a Back-Up Channel under the end of the panel and center 2" from the edge of the panel so that the rake end of the Back-Up Channel rests on the rake.
4. Fasten the End Dam with five (5) #12-14 x 1" SD NW screws. Fasteners must penetrate the End Dam, sealant, panel, and Back-Up Channel.
5. Apply a continuous $\frac{3}{8}$ " diameter bead of Tube Sealant (if necessary) where the End Dams meet the panel seams.

3:12 Slope
Minimum

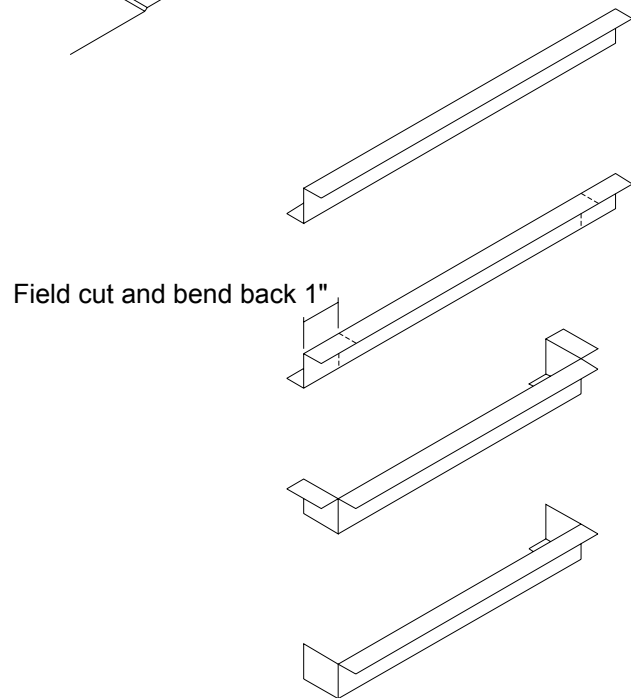
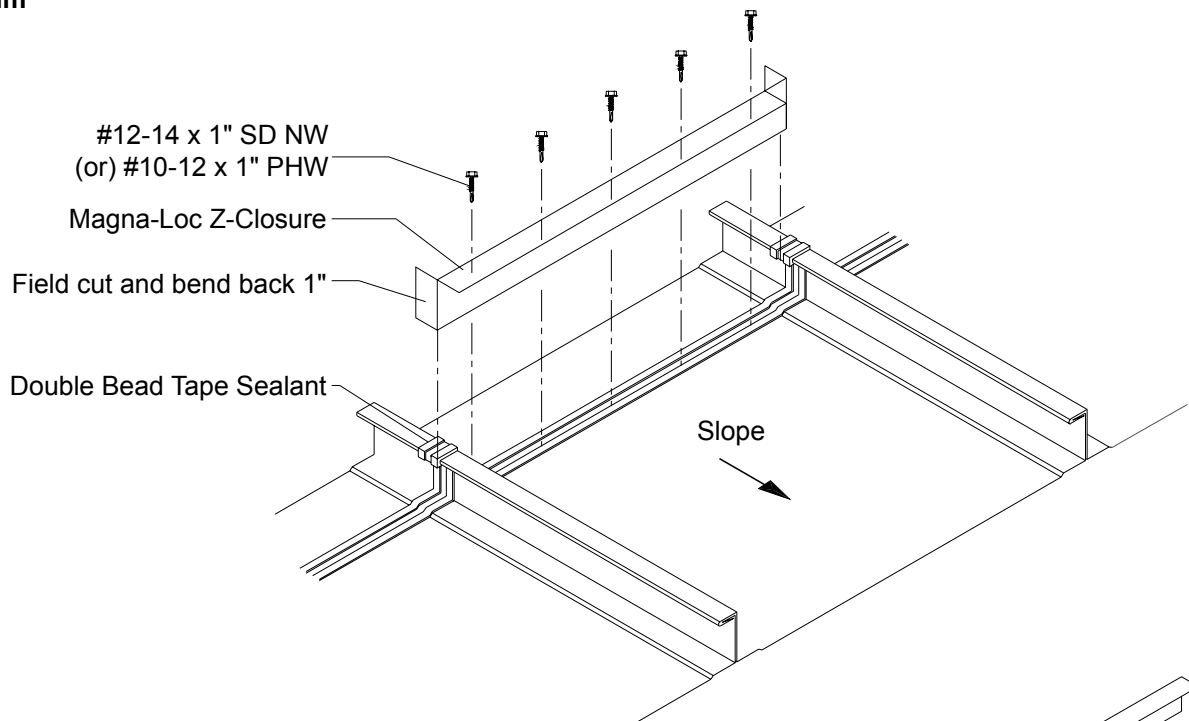

INSTALLATION NOTES

1. Place a row of Double Bead Tape Sealant across panel and over each rib approximately 4" from panel end. Before proceeding, make sure Z-Closure placement will accommodate flashing.
2. Field cut the Z-Closure 2" longer than the panel width. Snip the top and bottom leg of the Z-Closure and bend both sides back (as shown above).
3. Fasten through the Z-Closure, Tape Sealant, Magna-Loc panel, and substrate with appropriate fasteners.
Note: For Open Framing, the substrate will be the Back-Up Channel shown in the details.
4. Apply a row of Double Bead Tape Sealant across the top of the Z-Closure filling any gaps or openings around the panel ribs. This will be fastened through when the flashing is installed.

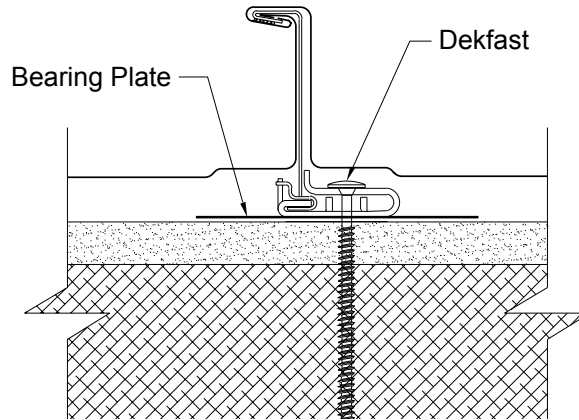

FLOATING SYSTEM WITH BEARING PLATE

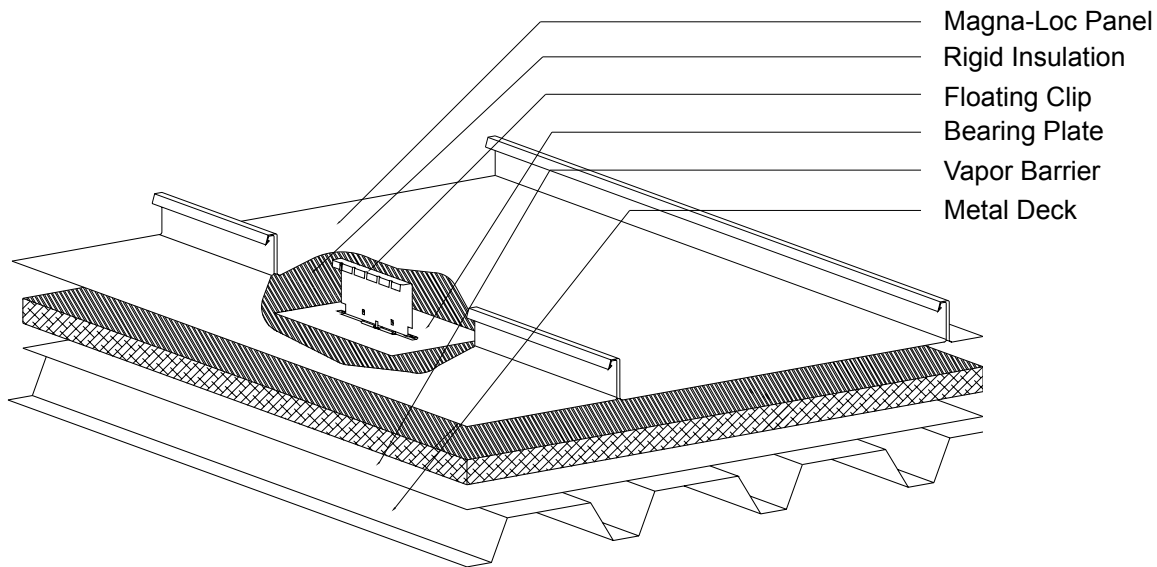

**FLOATING SYSTEM WITH
BEARING PLATE
-ISOMETRIC-**

MAGNA-LOC TRANSITION DETAIL

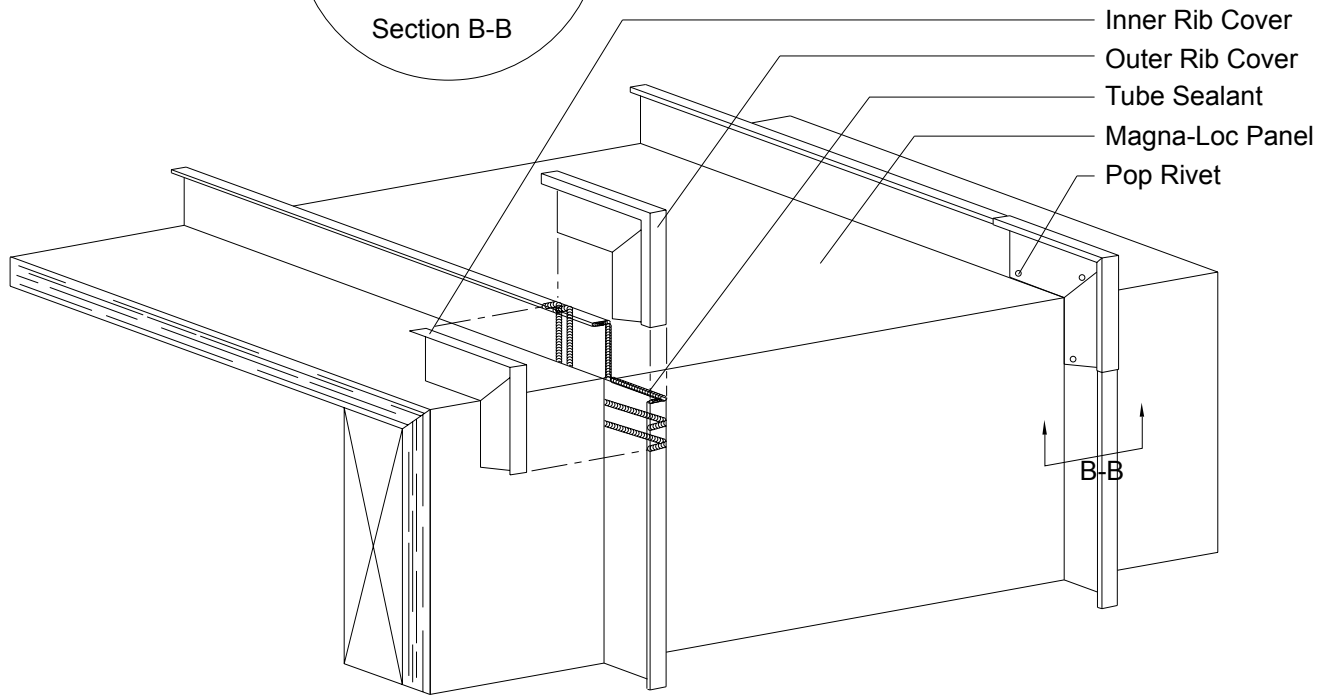
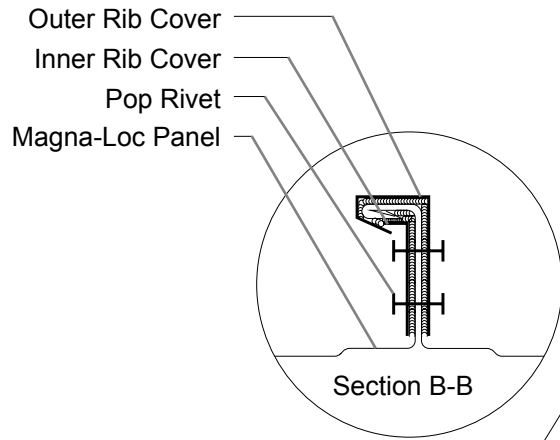

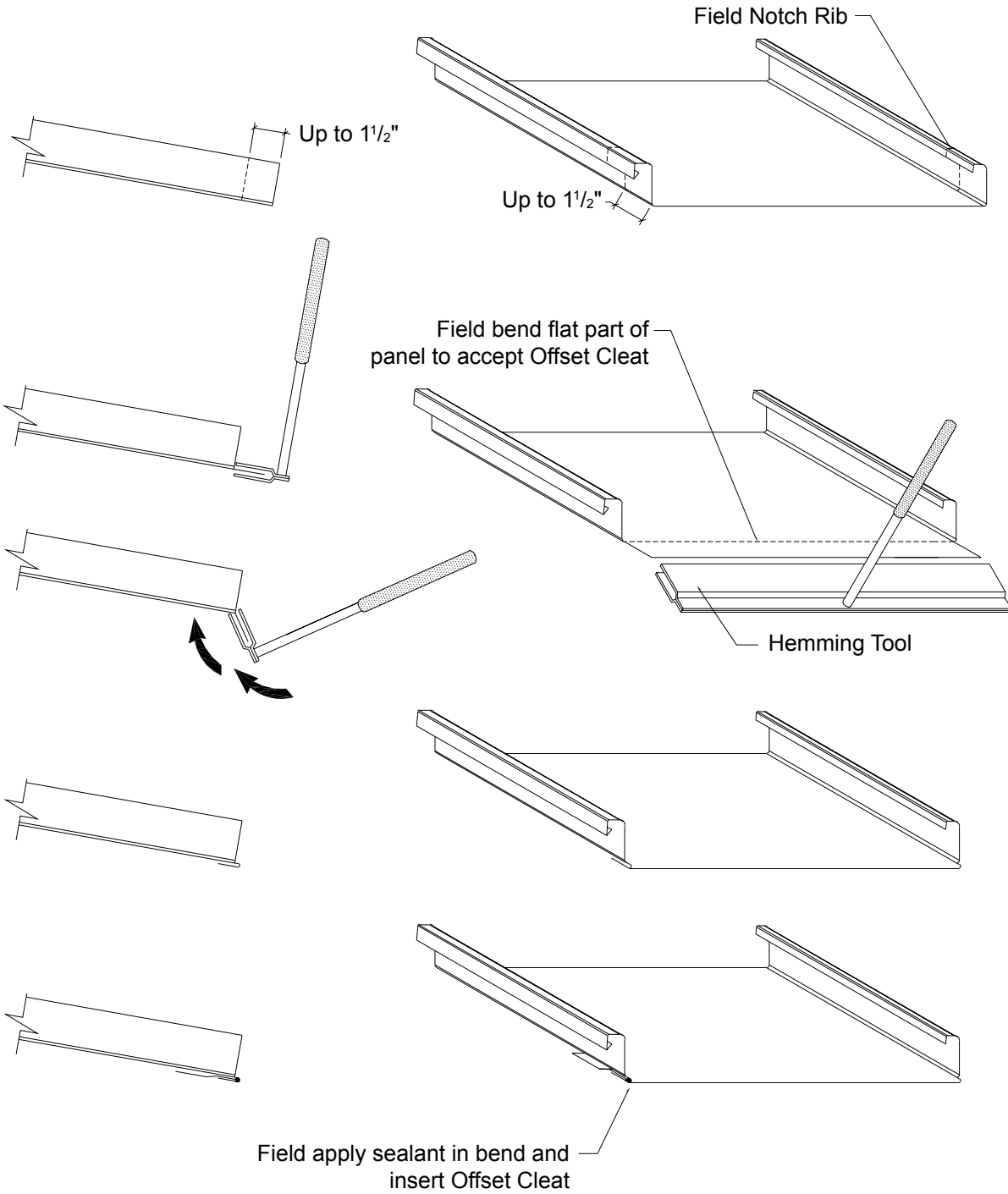

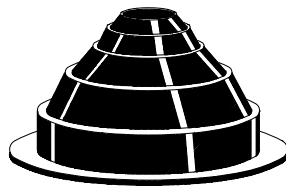
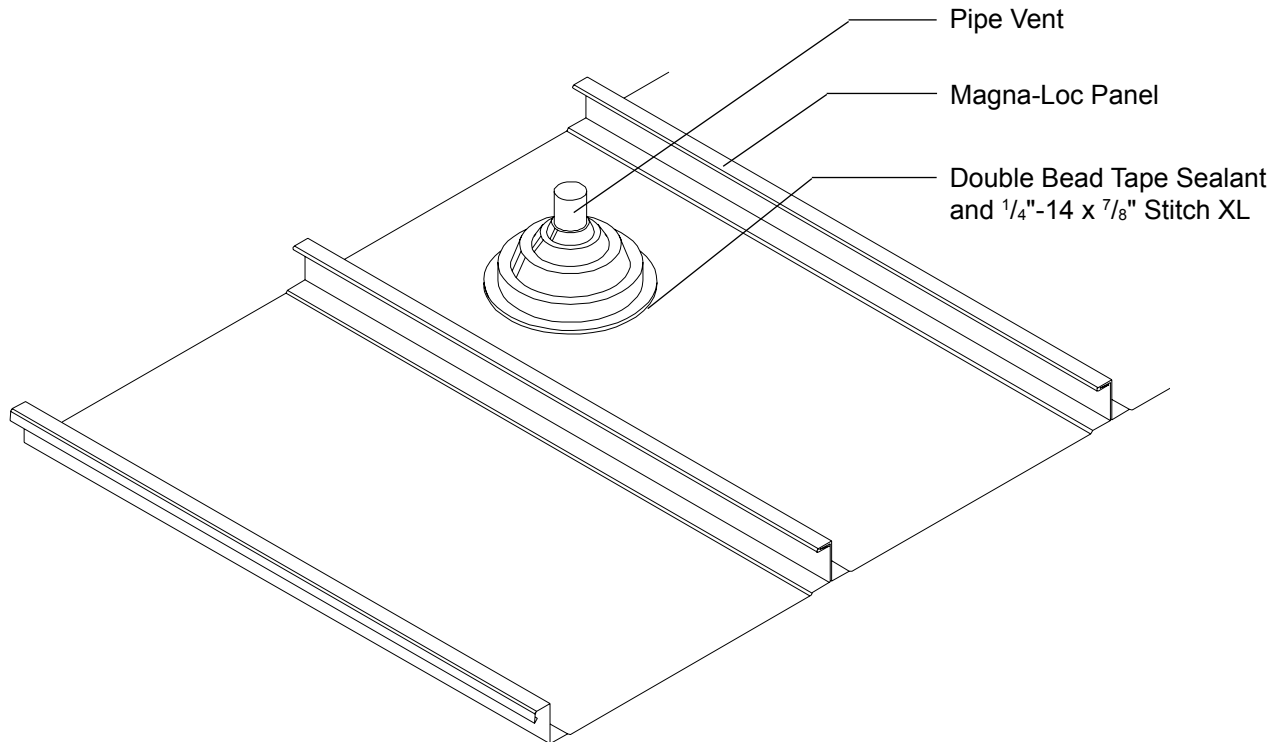

- Mini (1/4" to 1 1/8" O.D. Pipe)
- #2 (1 3/4" to 3" O.D. Pipe)
- #4 (3" to 6" O.D. Pipe)
- #6 (6" to 9" O.D. Pipe)
- #8 (7" to 13" O.D. Pipe)

TEMP RANGE: -30° to +250°

GENERAL NOTES

Size and location of all roof penetrations should be an important consideration. Areas around roof vents or rooftop units may show that corrosive fumes are emitted from a process within the building.

INSTALLATION NOTES

NOTE: The following procedures are for vent pipes 6" or less and not transmitting extremely hot or caustic materials. When installing vent pipes abide by the local plumbing codes.

1. Determine the size and length of the vent pipe to be raised.
2. Take the appropriate measurements for the vent location and mark them on the Magna-Loc panel. The vent pipe must extend through the flat of the roof panel. If the vent pipe extension cannot be raised directly into the flat of the new roof panel, elbows should be used to offset the pipe. Cut the panel to fit the vent pipe properly.
3. Use a light gauge angle to secure and plumb the vent pipe to the framing system.
4. Flash the vent pipe with a Rubber Roof Jack or similar pipe flashing.
5. Apply Tube Sealant between the panel and the base of the Rubber Roof Jack as well as the top where the boot meets the pipe.
6. Attach the base of the Rubber Roof Jack to the panel using 1/4"-14 x 7/8" Stitch XL fasteners.

Though factory applied prepainted finishes are very durable and will last many years, eventually it may be desirable to thoroughly clean or repaint them.

Dirt pickup may cause apparent discoloration of the paint when it has been exposed in some dirt laded atmospheres for long periods of time. In areas of strong sunlight, slight chalking may cause some change in appearance. A good cleaning will often restore the appearance of these buildings and render repainting unnecessary. An occasional light cleaning will help maintain a good appearance.

In many cases, simply washing the building with plain water using a hose or pressure sprayer will be adequate. In areas where heavy dirt deposits dull the surface, a cloth or soft bristle brush and solution of water and detergent ($\frac{1}{3}$ cup of laundry detergent per gallon of water for example) may be used. This should be followed by an adequate rinse of water. Do not use wire brushes, abrasives, or cleaning tools which will abrade the coating surface.

Mildew may occur in areas subject to high humidity but is not normally a problem due to the high inherent mildew resistance of the baked finish that is used. However, mildew can grow on dirt and spore deposits in some cases. To remove mildew along with the dirt, the following solution is recommended.

- $\frac{1}{3}$ cup detergent (Tide® or equivalent)
- $\frac{2}{3}$ cup trisodium phosphate (Solex® or equivalent)
- 1 quart of 5% sodium hypochlorite solution (Clorox® or equivalent)
- 3 quarts of water

Strong solvents and abrasive type cleaners should be avoided. Most organic solvents are flammable and toxic, and must be handled accordingly. When using a solvent, consult maintenance professionals and label instructions for proper handling and disposal of washings. If required, a mild solvent such as mineral spirits can be used to remove caulking compounds, oil, grease, tars, wax, and similar substances. Use a cloth dampened with mineral spirits and apply only to areas which are contaminated. Follow up the use of this mild solvent with detergent cleaning and rinsing.



**DO NOT USE A
WIRE BRUSH**

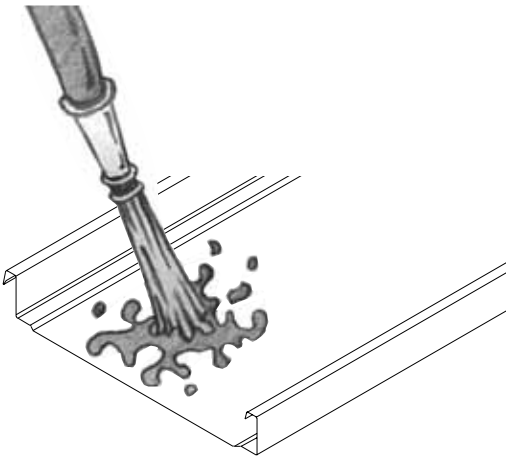

**HOSE OR PRESSURE SPRAY
FOR ADEQUATE CLEANING**



**USE MILD DETERGENT AND WATER
FOR HEAVY DIRT DEPOSITS**

